



MANITOU BF
BP 10249
44158 ANCENIS CEDEX - FRANCE
TEL: + 33 (0)2 40 09 10 11

YOUR DEALER

647414 EN (27/05/2015)

160 ATJ E3
160 ATJ E3 RC
180 ATJ 2 E3
180 ATJ 2 E3 RC
AUSTRALIA

INSTRUCTIONS MANUAL
(ORIGINAL INSTRUCTIONS MANUAL)



Foreword

This instruction for use is to explain the how to operate the lifting platform and the maintenance that must be performed periodically to ensure that the platform remains in a completely safe and operational condition.

The platform has been designed and produced to enable you to perform your overhead work completely safely.

Before it was delivered, MANITOU and the dealer have carefully inspected the platform so that it comes to you in perfect working order.



1 - SAFETY INSTRUCTIONS AND ADVICE

2 - DESCRIPTION

3 - MAINTENANCE

06 / 03 / 2014	1st PUBLICATION DATE
27 / 05 / 2015	UPDATE EN280



160 ATJ E3



180 ATJ 2 E3







1 - OPERATING AND SAFETY INSTRUCTIONS





TABLE OF CONTENTS

<i>INSTRUCTIONS TO THE COMPANY MANAGER</i>	<i>1-4</i>
<hr/>	
PREAMBLE	1-4
LE SITE	1-4
THE OPERATOR	1-4
THE PLATFORM	1-4
THE INSTRUCTIONS	1-5
THE MAINTENANCE	1-5
<i>INSTRUCTIONS FOR THE OPERATOR</i>	<i>1-6</i>
<hr/>	
PREAMBLE	1-6
GENERAL INSTRUCTIONS	1-6
DRIVING INSTRUCTIONS	1-8
INSTRUCTIONS FOR WELDING AND BLOW TORCH WORK ON THE EXTERNAL STRUCTURE	1-22
<i>PLATFORM MAINTENANCE INSTRUCTIONS</i>	<i>1-24</i>
<hr/>	
GENERAL INSTRUCTIONS	1-24
MAINTENANCE	1-24
LUBRICANT AND FUEL LEVELS	1-24
LEVEL OF ELECTROLYTE IN THE BATTERY	1-24
HYDRAULIC	1-25
ELECTRICITY	1-25
WELDING ON THE ACCESS PLATFORM	1-25
WASHING THE PLATFORM	1-25
<i>IF THE PLATFORM IS NOT TO BE USED FOR A LONG TIME</i>	<i>1-26</i>
<hr/>	
INTRODUCTION	1-26
PREPARING THE PLATFORM	1-26
PROTECTING THE I.C. ENGINE	1-26
CHARGING THE BATTERIES	1-27
PROTECTING THE PLATFORM	1-27
BRINGING THE PLATFORM BACK INTO SERVICE	1-27
<i>SCRAPPING THE NACELLE</i>	<i>1-28</i>
<hr/>	
<i>SAFETY DECALS</i>	<i>1-30</i>
<hr/>	



INSTRUCTIONS TO THE COMPANY MANAGER

PREAMBLE

WHENEVER YOU SEE THIS SYMBOL IT MEANS :



**WARNING ! BE CAREFUL ! YOUR SAFETY OR
THE SAFETY OF THE PLATFORM IS AT RISK.**

THE SITE

- Good personal control of the lifting platform's operating area reduces the risk of accidents:
 - The floor must not be unnecessarily broken or cluttered,
 - No excessive slopes,
 - Controlled pedestrian traffic, etc.

THE OPERATOR

- Only qualified, authorized personnel can use the platform. This authorization is given in writing by the appropriate person in the establishment with respect to the use of platform and must be carried permanently by the operator.

On the basis of experience, there are a number of possible situations in which operating the platform is contra-indicated. Such foreseeable abnormal uses, the main ones being listed below, are strictly forbidden.

- The foreseeable abnormal behaviour resulting from ordinary neglect, but does not result from any wish to put the machinery to any improper use.



The reflex reactions of a person in the event of a malfunction, incident, fault, etc. during operation of the platform.

- Behaviour resulting from application of the "principle of least action" when performing a task.
- For certain machines, the foreseeable behaviour of such persons as : apprentices, teenagers, handicapped persons, trainees tempted to drive a platform, operator tempted to operate a truck to win a bet, in competition or for their own personal experience.
- The person in charge of the equipment must take these criteria into account when assessing whether or not a person will make a suitable driver.



OBTAIN INFORMATION ON :

- How to behave when there is a fire.
- The location of the nearest first aid kit and fire extinguisher.
- The emergency telephone numbers for calling (the doctors, ambulance, hospital and fire brigade).

THE PLATFORM

A - THE PLATFORM'S SUITABILITY FOR US

- MANITOU has ensured that this platform is suitable for use under the standard operating conditions defined in this operator's manual, with an overload test coefficient of 1,25 and an operational test coefficient of 1,1, as stipulated in standardised norm EN 280 for MPLPs (Mobile Personnel Lifting Platforms).

Before commissioning, the company manager must make sure that the platform is appropriate for the work to be done, and perform certain tests (in accordance with current legislation).

B - ADAPTATING THE PLATFORM TO THE USUAL ENVIRONMENTAL CONDITIONS

- In addition to series equipment mounted on your platform, many options are available, such as : flashing light, working headlight, etc. Contact your dealer.
- Take into account climatic and atmospheric conditions of the site of utilisation.
 - Protection against frost (see chapter 3 - MAINTENANCE, LUBRICANTS page).
 - Adaptation of lubricants (ask your dealer for information).
 - I.C. engine filtration (see chapter 3 - MAINTENANCE, FILTER ELEMENTS page).



- The machines designed by MANITOU are designed to be used in the following temperature range:
 - Minimum temperature: -20°C
 - Maximum temperature: +45°C
- Special features are available, as an option, for particularly cold environments.



For operation under average climatic conditions, i.e. : between -15 °C and + 35 °C, correct levels of lubricants in all the circuits are checked in production. For operation under more severe climatic conditions, before starting up, it is necessary to drain all the circuits, then ensure correct levels of lubricants using lubricants properly suited to the relevant ambient temperatures. It is the same for the cooling liquid.

- A platform operating in an area without fire extinguishing equipment must be equipped with an individual extinguisher. There are solutions, consult your dealer.



Your platform is designed for outdoor use (see chapter: 2 - DESCRIPTION, CHARACTERISTICS pages) under normal atmospheric conditions and indoor use in suitably aerated and ventilated premises. It is prohibited to use the platform in areas where there is a risk of fire or which are potentially explosive (e.g. Refineries, fuel or gas depots, stores of inflammable products...). For use in these areas, specific equipment is available (ask your dealer for information).

C - MODIFYING THE PLATFORM

- For your safety and that of others, you must not change the structure and settings of the various components used in your platform (hydraulic pressure, calibrating limiters, I.C. engine speed, addition of extra equipment, addition of counterweight, unapproved attachments, alarm systems, etc.) yourself. In this event, the manufacturer cannot be held responsible.
- Your lifting platform is delivered with standard wheels or all-terrain wheels. It is FORBIDDEN to switch from one type of wheels to another: RISK OF THE LIFTING PLATFORM BECOMING UNSTABLE.

THE INSTRUCTIONS

- The operator's manual must always be in good condition and kept in the place provided on the platform and in the language used by the operator.
- You must necessarily replace the instructions manual, as well as any plates or stickers, if they are no longer legible or are missing or damaged.

THE MAINTENANCE

- Maintenance or repairs other than those detailed in the chapter 3 - MAINTENANCE must be carried out by qualified personnel (consult your dealer) and under the necessary safety conditions to maintain the health of the operator and any third party.



Your platform must be inspected periodically to ensure that it remains in compliance. The frequency of this inspection is defined by current legislation in the country in which the platform is use

- Example for France : The manager of the company using the platform must set up a maintenance book for each machine and keep up-to-date (Ministerial Order of 2nd March 2004).

INSTRUCTIONS FOR THE OPERATOR

PREAMBLE

WHENEVER YOU SEE THIS SYMBOL IT MEANS :



**WARNING ! BE CAREFUL ! YOUR SAFETY OR
THE SAFETY OF THE PLATFORM IS AT RISK.**



The risk of accident while using, servicing or repairing your platform can be restricted if you follow the safety instructions and safety measures detailed in these instruction.

- Only the operations and manoeuvres described in these operator's manual must be performed. The manufacturer cannot predict all possible risky situations. Consequently, the safety instructions given in the operator's manual and on the platform itself are not exhaustive.
- At any time, as an operator, you must envisage, within reason, the possible risk to yourself, to others or to the platform itself when you use it.



Failure to respect the safety and operating instructions, or the instructions for repairing or servicing your platform may lead to serious, even fatal accident.

GENERAL INSTRUCTIONS

A - operator's manual

- Carefully read and understand the operator's manual.
- The operator's manual must always be kept in the place provided for it on the platform and be written in the language used by the operator.
- Any operations or manoeuvres not described in the operator's manual must necessarily be forbidden right from the start.
- Follow the safety advice and the instructions on the platform.
- Ypu must necessarily replace the operator's manual, as well as any plates or stickers, if they are no longer legible or are damaged.
- A second operator must necessarily be present on the ground as a safety measure when using the platform.
- Familiarise yourself with the platform on the terrain it has to travel over.
- The machine must also be used in accordance with good engineering practice.
- Do not use the platform if the wind speed is over 45 km/h. The platform's arms must not be subjected to a lateral force of more than 40 kg (platforms for indoor use must not be used outside the building).

B - AUTHORIZATION FOR USE IN FRANCE

(OR SEE CURRENT LEGISLATION IN OTHER COUNTRIES)

- Only qualified, authorized personnel may use the platform. This authorization is given in writing by the appropriate person in the company, in charge of using the platform, and must be permanently carried by the operator.
- The operator is not competent to authorise the driving of the platform by another person.



C - MAINTENANCE

- The operator must immediately advise his superior if his platform is not in good working order or does not comply with the safety notice.
- The operator is prohibited from carrying out any repairs or adjustments himself, unless he has been trained for this purpose. He must keep the platform properly cleaned if this is among his responsibilities.
- The operator must carry out daily maintenance (see chapter : 3 - MAINTENANCE, A - DAILY pages).
- The operator must ensure tyres are adapted to the nature of the ground (see area of the contact surface of the tyres in the chapter : 2 - DESCRIPTION : CHARACTERISTICS pages). There are optional solutions, consult your dealer.



Do not use the platform if the tyres are damaged or excessively worn, because this could put your own safety or that of others at risk, or cause damage to the platform itself.



In the case of electric platforms, the operator must ensure that:

- **The batteries are not replaced with lighter ones (compromising stability).**
- **Safety goggles are always worn when charging the batteries.**
- **The batteries are not charged in an explosive environment.**
- **There is no smoking and no naked flame directed towards the batteries when they are being handled during removal, re-installation and checking the levels.**

D - MODIFYING THE PLATFORM

- For your safety and that of others, you must not change the structure and settings of the various components used in your platform yourself:
 - hydraulic pressure,
 - calibrating limiters,
 - I.C. engine speed,
 - addition of extra equipment,
 - addition of counterweight,,
 - unapproved attachments,
 - alarm systems, etc...
- In this event, the manufacturer cannot be held responsible.



Your lifting platform is delivered with standard wheels or all-terrain wheels. It is FORBIDDEN to switch from one type of wheels to another: RISK OF THE LIFTING PLATFORM BECOMING UNSTABLE.

E - IC PLATFORM AXLES

- STANDARD AXLE :



The chassis is rigid, so the platform can have a ground reach on only three wheels.

- OSCILLATING AXLE (IF THIS OPTION IS AVAILABLE) :



An oscillating axle enables the platform, when in transport position, to have a ground reach on four wheels. When moving in working position over uneven terrain, the oscillating axle is locked (the chassis is rigid) so the platform can have a ground reach on only three wheels.



DRIVING INSTRUCTIONS

A - BEFORE STARTING THE PLATFORM

- Ensure that the intermediate rail is fully in the locked position before operating the platform from the basket.
- If the platform is new, see the paragraph : before starting the platform for the first time in Chapter : 1 - safety advice and instructions.
- Carry out daily maintenance (see chapter 3 - MAINTENANCE, A - DAILY pages).
- Before starting the platform, check the levels :

- IC PLATFORMS :

- IC engine oil
- Hydraulic reservoir oil
- Fuel
- Coolant

- ELECTRIC PLATFORMS :

- Hydraulic reservoir oil
- Battery charge level

- The lifting platform must be in transport position (with the arms completely folded back or the scissors in the low position) before you enter it.
- Make sure the horn works.
- Check before you use the lifting platform that the access door is properly locked.

B - DRIVER'S OPERATING INSTRUCTIONS

- Whatever his experience, the operator is advised to familiarize himself with the position and operation of all the controls and instruments before operating the platform.
- Wear suitable clothing for driving the platform, do not wear baggy clothes.
- Make sure you have the appropriate protective equipment for the job to be done.
- Prolonged exposure to high noise levels may cause hearing problems. It is recommended to wear ear muffs to protect against excessive noise.
- Always pay attention when using the platform. Do not listen to the radio or music using headphones or earphones
- For increased comfort, adopt the correct position in the driver's cab.
- The operator must always be in his normal position in the driver's seat : extending arms or legs (or, in general, any part of the body), outside the basket is forbidden.
- Safety helmets must be worn.
- MANITOU recommends a safety harness in the operator's size be provided when the platform is in use (for the harness attachment in the basket , see chapter 2 - DESCRIPTION, CHECKING AND CONTROL INSTRUMENTS pages).
- The control units must never in any event be used for any other than their intended purposes (e.g. climbing onto or down from the platform, coat-rack, etc.).
- In the case of scissors-type platforms, it is forbidden to use the platform without the guardrails in place.
- Suspending a load under the basket or on any part of the lifting apparatus is strictly forbidden.
- The operator must not climb into or get down from the basket unless it is at ground level (with the lifting system folded).
- If the nacelle is equipped with a step, the basket must be situated directly below it before mounting or dismounting.
- The platform must not be fitted with any accessory increasing the machine's wind profile.
- Do not use a ladder or any improvised constructions in the basket to reach greater heights.
- Do not climb on the sides of the basket to reach greater heights.
- Never use the lifting platform with wet or greasy hands and shoes.

C - ENVIRONMENT

- Comply with site safety regulations.
- The platform can be manoeuvred from the ground: ensure that you forbid access.
- If you have to use the platform in a dark area or at night, make sure it is equipped with working lights.
- The platforms may not be used as cranes or elevators for the permanent transport of people or materials, nor as jacks or supports.
- When operating, ensure that there is no one or anything impeding the platform's progress and operation.
- When raising the platform, ensure that no one or anything impedes the platform's operation and do not perform any inappropriate manoeuvres.



- Do not allow anybody to come near the working area of the platform or pass beneath an elevated load. To do this, mark your operating area with warning signs.
- Travelling on a longitudinal slope :
 - Ensure that you adapt the platform's travelling speed by controlling the speed with the travelling manipulator.
- Take into account the platform's dimensions and its load before trying to negotiate a narrow or low passageway.
- Never move onto a loading platform without having first checked :
 - That it is suitably positioned and made fast.
 - That the unit to which it is connected (wagon, lorry, etc.) will not shift.
 - That this platform is prescribed for the size and the total weight of the platform.
 - That the slope is not greater than the platform's maximum authorised slope.
- Never move onto a foot bridge, floor or freight lift, without being certain that they are prescribed for the weight and size of the platform to be loaded and without having checked that they are in sound working order.
- Be careful in the area of loading bays, trenches, scaffolding, soft land and manholes.
- Ensure that the ground under the wheels and/or stabilisers is firm and stable before raising the basket.
- Do not attempt any operations outside the platform's capabilities.
- Ensure that the materials on the platform (pipes, cables, containers, etc ...) cannot slip off and fall. Do not heap up these materials to the point where you have to step over them.



If the basket must remain stationary over a structure for a long period, there is a risk that the basket will rest on this structure because of the oil cooling in the cylinders or a minor leak in the cylinder locking system. To eliminate this risk :
 - Regularly check the distance between the basket and the structure and re-adjust if necessary.
 - If possible use the platform at an oil temperature as close as possible to ambient temperature.

- In the case of work near aerial lines, ensure that the safety distance is sufficient between the working area of the platform and the aerial line.



You must consult your local electrical agency. You could be electrocuted or seriously injured if you operate or park the platform too close to power cables.



If the platform comes into contact with electric wires, press the Emergency Stop button. If you can, jump from the basket without simultaneously being in contact with the basket and the ground.
 If not, call for help, warn people not to touch the basket and to switch off the power supply to the wires or have it switched off.

- It is forbidden to use the lifting platform close to electrical power lines; observe the safety distances.

NOMINAL VOLTAGE IN VOLTS	DISTANCE ABOVE THE GROUND OR THE FLOOR IN METRES
50 < U < 1000	2,30 M
1000 < U < 30000	2,50 M
30000 < U < 45000	2,60 M
45000 < U < 63000	2,80 M
63000 < U < 90000	3,00 M
90000 < U < 150000	3,40 M
150000 < U < 225000	4,00 M
225000 < U < 400000	5,30 M
400000 < U < 750000	7,90 M



C1 - operation near aerial conductors (overhead power lines)

“Reproduced from as2550.1”

C1-1 general

This clause refers to hazards and risks presented by the set-up and operation of the platform in the vicinity of overhead electrical conductors.

Notes:

1 Electricity supply bodies in each state may have issued guidelines for the use of platforms and other plant in the vicinity of overhead conductors; for example, the electricity association of new south wales' publication 'interim guide for operating platforms and plant in proximity to overhead power lines'.

2 A conservative approach has been adopted. Separation distances have not been chosen based purely on electrical voltages of conductors, nor whether the conductor is bare or insulated.

The distances were chosen based on experience and practical considerations, since platforms cannot be operated as accurately as arcing distances can be calculated.

Before operating the platform from the stowed condition, a check for the presence of overhead conductors and power lines shall be undertaken.

Throughout clause a, the following definitions apply:

(a) aerial conductor—an overhead conductor that is either insulated or bare.

(b) Operation—where any platform components are moved or about to be moved from their stowed position.

(c) Overhead power line—aerial conductors and other parts that make up an aerial line for the distribution and transmission of electrical energy.

(d) Electricity distributor—the power supply authority, transmission line operator, generator, traction company or distribution company.

All aerial conductors shall be treated as alive unless the platform operator has received, from the electricity distributor or transmission line operator, documentary evidence that the conductors have been positively de-energized, isolated and earthed.

Where such documentary evidence has been made available, it shall state the date and time frame of isolation and any special conditions and precautions. The platform shall not be operated in contravention of this documentary information.

C1-2 Precautions when operating near live aerial conductors

The platform shall only be operated within close proximity of live aerial conductors, if the separation distances appropriate to the 'NO-GO-ZONE' or 'SPOTTER-REQUIREDZONE', and risk controls given in Clause C1.3, are maintained.

A site-specific risk assessment shall be completed before the commencement of the job by a trained and competent person. This assessment shall be verified immediately before work commences, and its relevance monitored during the job. If initial associated circumstances change, work shall cease until an appropriate risk assessment is undertaken.

Where a spotter is required to inform the operator in the event of the platform approaching the zone boundaries shown, the following applies:

(a) The spotting operation shall be carried out by a competent person.

NOTE: Required competency levels may be defined by the Office of the Chief Electrical Inspector or similar body in the applicable State.

(b) The spotter shall be positioned so as to minimize the risk of exposure to hazards.

(c) The spotter shall be able to clearly observe the separation distances.

(d) The spotter shall not undertake any other work whilst performing spotting duties.

(e) The spotter shall be specifically instructed in the workplace hazards applicable to the site.

(f) The spotter shall be able to communicate with the platform operator at all times during erection, operation and dismantling.



C1-3 Separation distances and risk controls

Where possible, the zone separation distances shall be not less than those shown in Figure C1.3.

NOTE: The separation distances shown in Figure C1.3 include allowance for sag and sway of line(s) due to the effects of wind and temperature.

Where the separation distances cannot be achieved, the electricity distributor shall be notified in writing. The platform shall not be operated within the 'no go zone' until the applicable requirements below are satisfied.

The separation distance between the platform and aerial conductor and risk controls when operating in the vicinity of aerial conductors shall comply with the following:

(a) Overhead power lines (up to and including 133 kV) The following applies:

(i) No go zone The platform shall not be operated in the 'no go zone' as indicated in Figure A.3 for overhead power lines up to and including 133 kV, unless —

- (A) written permission from the electricity distributor has been obtained;
- (B) all conditions specified by the electricity distributor are complied with;
- (C) the electricity distributor is notified before commencing work;
- (D) a spotter performs spotting duties; and
- (E) a pre-start site/job meeting has been convened and a risk assessment completed.

(ii) Spotter required zone The platform shall not be operated in the 'spotter required zone' as indicated in Figure C1.3 for overhead power lines up to and including 133 kV, unless—

- (A) written permission from the electricity distributor has been obtained;
- (B) a spotter performs spotting duties; and
- (C) a pre-start site/job meeting has been convened and a risk assessment completed.

(b) Overhead power lines (greater than 133 kV) The following applies:

(i) No go zone The platform shall not be operated in the 'no go zone' as indicated in Figure C1.3 for overhead power lines greater than 133 kV, unless —

- (A) an easement entry permit has been provided by the electricity distributor;
- (B) written permission from the electricity distributor has been obtained;
- (C) all conditions specified by the electricity distributor are complied with;
- (D) the electricity distributor is notified before commencing work;
- (E) a spotter performs spotting duties; and
- (F) a pre-start site/job meeting has been convened and a risk assessment completed.

(ii) Spotter required zone The platform shall not be operated in the 'spotter required zone' as indicated in Figure 6.19.3 for overhead power lines greater than 133 kV, unless—

- (A) written permission from the electricity distributor has been obtained;
- (B) an easement entry permit has been provided by the electricity distributor;
- (C) a spotter performs spotting duties; and
- (D) a pre-start site/job meeting has been convened and a risk assessment completed.

(c) Public transport authorities Where aerial conductors are dedicated to the use of public transport authorities, e.g., tramways and railways, the separation distance shall be the same as that for aerial conductors up to and including 133 kV (see Item (a)).



The separation distance between the platform and aerial conductor and risk controls when operating in the vicinity of aerial conductors shall comply with the following:

(a) Overhead power lines (up to and including 133 kV) The following applies:

(i) No go zone The platform shall not be operated in the 'no go zone' as indicated in Figure C1.3 for overhead power lines up to and including 133 kV, unless —

- (A) written permission from the electricity distributor has been obtained;
- (B) all conditions specified by the electricity distributor are complied with;
- (C) the electricity distributor is notified before commencing work;
- (D) a spotter performs spotting duties; and
- (E) a pre-start site/job meeting has been convened and a risk assessment completed.

(ii) Spotter required zone The platform shall not be operated in the 'spotter required zone' as indicated in Figure C1.3 for overhead power lines up to and including 133 kV, unless—

- (A) written permission from the electricity distributor has been obtained;
- (B) a spotter performs spotting duties; and
- (C) a pre-start site/job meeting has been convened and a risk assessment completed.

(b) Overhead power lines (greater than 133 kV) The following applies:

(i) No go zone The platform shall not be operated in the 'no go zone' as indicated in Figure C1.3 for overhead power lines greater than 133 kV, unless —

- (A) an easement entry permit has been provided by the electricity distributor;
- (B) written permission from the electricity distributor has been obtained;
- (C) all conditions specified by the electricity distributor are complied with;
- (D) the electricity distributor is notified before commencing work;
- (E) a spotter performs spotting duties; and
- (F) a pre-start site/job meeting has been convened and a risk assessment completed.

(ii) Spotter required zone The platform shall not be operated in the 'spotter required zone' as indicated in Figure 6.19.3 for overhead power lines greater than 133 kV, unless—

- (A) written permission from the electricity distributor has been obtained;
- (B) an easement entry permit has been provided by the electricity distributor;
- (C) a spotter performs spotting duties; and
- (D) a pre-start site/job meeting has been convened and a risk assessment completed.

(c) Public transport authorities Where aerial conductors are dedicated to the use of public transport authorities, e.g., tramways and railways, the separation distance shall be the same as that for aerial conductors up to and including 133 kV (see Item (a)). (d) Downshop conductors Before mobile machinery is set up for operation in the vicinity of downshop conductors, the power supply to the conductors shall be isolated prior to operation unless appropriate control measures have been developed and implemented.

NOTES:

- 1 Downshop conductors, e.g., collector rails, should be clearly identified.
- 2 Clearances from downshop conductors should be in accordance with AS/NZS 3000.

(e) Barriers at ground level Where people not involved in the lifting operation could otherwise come into the



area of possible voltage step potential, barriers shall be provided at ground level to prevent this from occurring. Appropriate warning signs shall be displayed on the barriers. Pedestrians should be barricaded from the area of possible voltage step potential (see Figure 6.19.4) in the vicinity of the crane and associated equipment.

(f) Person to platform contact Only the platform operator shall be in contact with any part of the platform during operation.

(g) Earthing systems An appropriate earthing system shall be fitted to the platform and shall be in use. Operators and those working in proximity to the platform shall be advised of the limits of the effectiveness of the earthing equipment.

NOTE: The purpose of the earthing system is to provide an alternate path to earth to minimize risks to personnel and plant, and it may not be likely to trip circuit breakers that form part of the electricity transmission system.

(h) High visibility bunting Where high visibility bunting is applied to the conductors, it shall not be regarded as insulation.



FIG. C1.3 CLEARANCES FROM LIVE AERIAL CONDUCTORS

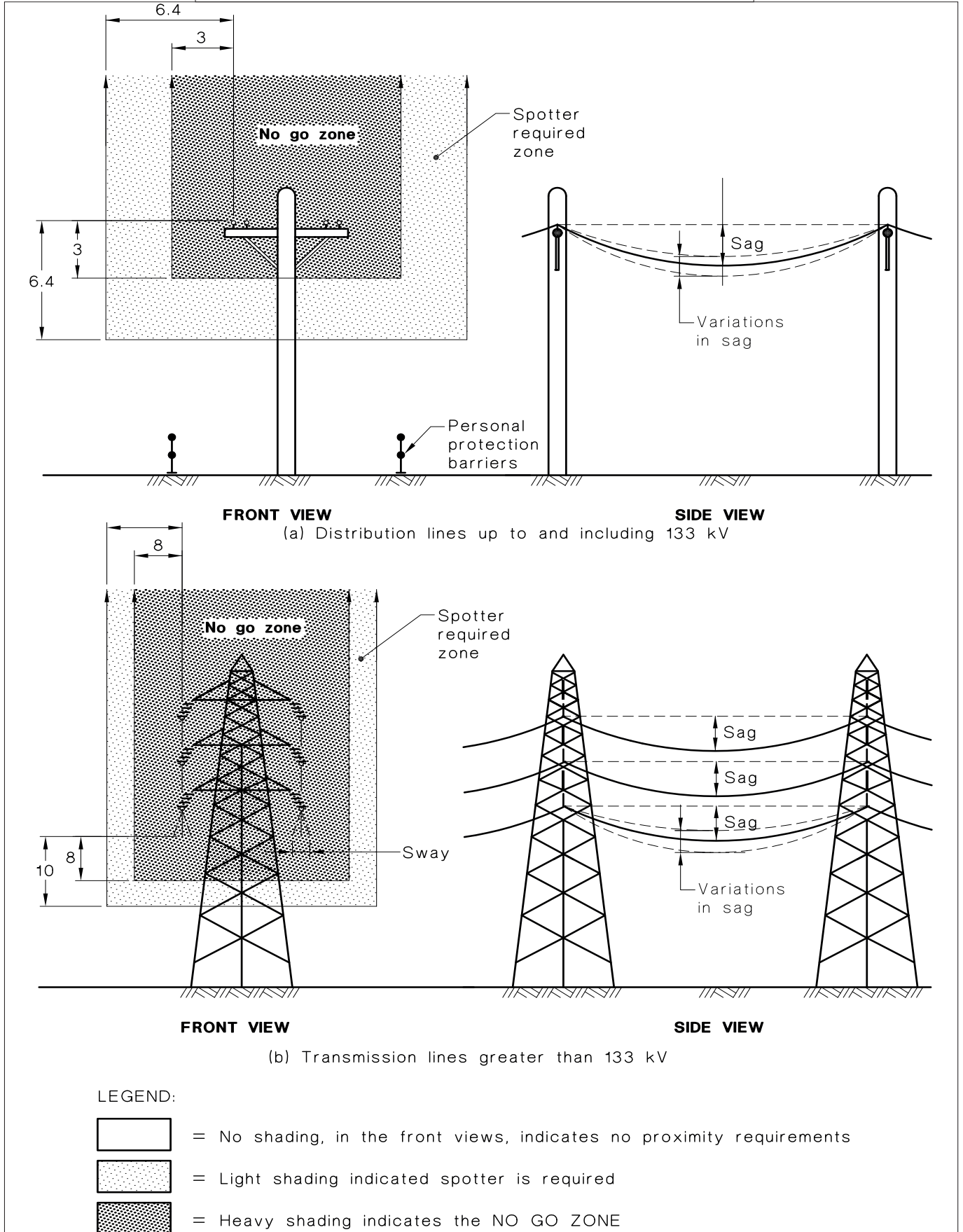

**C1-4 Aerial conductor contact**

If the platform or load contacts aerial conductors, the relevant electricity distributor shall be immediately notified of the situation and, until assistance is received, a competent person shall remain in a prominent position to warn of the danger of electrocution.

In such an event the platform operator should act as follows:

- (a) Remain the platform.
- (b) Warn all other personnel to keep away from the platform and not to touch any part of the platform.
- (c) Without anyone approaching the platform, operate the platform in such a manner to break contact, where possible.
- (d) When unable to move or disentangle the platform from the aerial conductors, remain on the platform and take no further action until it is confirmed that conditions are safe.

Where the platform operator is immobilized, the power shall be isolated before assistance is given.

When a platform has been in contact with a live aerial conductor, it shall be checked by a competent person for any damage. Any actions recommended by the competent person shall be completed before it is returned to service.

FIG. C1.4 TYPICAL AFFECTED AREA SURROUNDING A PLATFORM WHEN IN CONTACT WITH A LIVE AERIAL CONDUCTOR

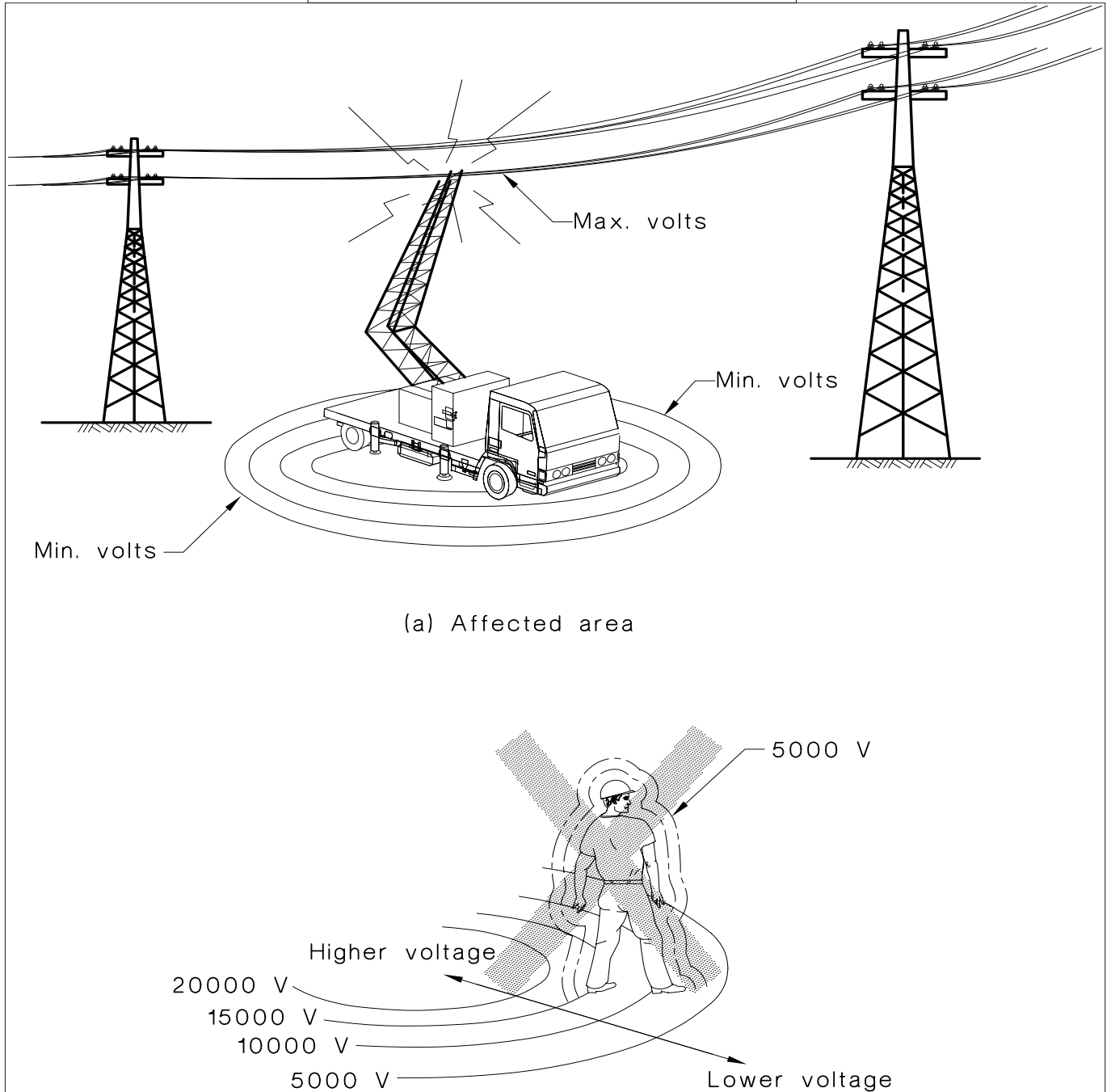



If the wind is in excess of 45Km/h, do not perform any movements liable to endanger the lifting platform's stability.

- To recognise this speed by eye, please refer to the empirical wind evaluation scale below:

BEAUFORT scale (wind speed at a height of 10m over flat terrain)						
Degree	Type of wind	Speed (knots)	Speed (km/h)	Speed (m/s)	Ground effects	Sea conditions
0	Calm	0 - 1	0 - 1	< 0,3	Smoke rises vertically.	The sea is like a mirror.
1	Very light breeze	1 - 3	1 - 5	0,3 - 1,5	The smoke drift indicates the wind direction.	Some wavelets, like fish scales, but no foam.
2	Light breeze	4 - 6	6 - 11	1,6 - 3,3	Wind felt on exposed skin, leaves rustle.	Small but noticeable wavelets.
3	Gentle breeze	7 - 10	12 - 19	3,4 - 5,4	Leaves and small twigs constantly moving.	Very small waves, crests beginning to break.
4	Moderate breeze	11 - 16	20 - 28	5,5 - 7,9	The wind raises dust and scraps of paper, it moves small branches.	Small waves stretching, many sheeps.
5	Fresh breeze	17 - 21	29 - 38	8 - 10,7	Small trees in leaf start to sway.	Wavelets form on stretches of water, moderate waves of some length.
6	Strong breeze	22 - 27	39 - 49	10,8 - 13,8	Large branches are moved, overhead wires whistle, umbrella use becomes difficult.	Waves form with white foam crests and airborne spray.
7	High wind	28 - 33	50 - 61	13,9 - 17,1	Whole trees are moving, effort required to walk against the wind.	The sea heaps up; some foam from breaking waves is blown into streaks in the wind direction.
8	Gale	34 - 40	62 - 74	17,2 - 20,7	The wind breaks off twigs, walking against the wind is very difficult.	Moderate height longer waves with breaking crests forming spindrift.
9	Strong gale	41 - 47	75 - 88	20,8 - 24,4	The wind damages roofs (chimneys, tiles, etc.).	Large waves, dense spindrift wrenched from the waves, airborne spray reducing visibility.
10	Storm	48 - 55	89 - 102	24,5 - 28,4	Rarely seen on land, trees uprooted, dwellings incur significant damage.	Very large waves, foam forming large amounts of airborne spray, reducing visibility.
11	Violent storm	56 - 63	103 - 117	28,5 - 32,6	Very rare, extensive damage.	Waves of exceptional height capable of sinking medium-sized ships, reduced visibility.
12	Hurricane	64 +	118 +	32,7 +	Disastrous damage.	Sea completely white, air full of spray and foam, severely reduced visibility.



D - VISIBILITY

- Maintain permanently good visibility throughout the route. To increase your visibility, you can move forwards with the pendular arm slightly raised (pay attention to the risk of falls in the basket from knocking into a low doorway, overhead electric wires, travelling cranes, highway bridges, tracks or any obstacle in the area in front of the platform). In reverse, look directly behind you. In any case, avoid reversing over long distances.
- If visibility of your road is inadequate, ask someone to help, standing outside the area in which the platform will be moving, and make sure you always have a good view of this person.



E - STARTING THE PLATFORM

PLATFORMS WITH IC ENGINES

SAFETY NOTICE

- Do not pull or push the lifting platform to start it. This type of manoeuvre would cause severe damage to the transmission. In cases of necessity, towing requires that the lifting platform be placed in freewheeling mode (See chapter 3 - MAINTENANCE).
- If using an emergency battery for start-up, use a battery with the same characteristics and respect battery polarity when connecting it. Connect at first the positive terminals before the negative terminals.



Failure to respect polarity between batteries can cause serious damage to the electrical circuit. The electrolyte in the battery may produce an explosive gas. Avoid flames and generation of sparks close to the batteries.
Never disconnect a battery while it is charging.

INSTRUCTIONS

- Check the closing and locking of the hood(s).
- Turn the ignition key to notch I to switch on the electrical power, which automatically starts the pre-heating system (all the bars must be displayed), the message "OK" is displayed.
- Check that everything is operating correctly by ensuring that no fault pages are displayed on the screen and no warning about the fuel level (a pump icon is present on the screen) (see chapter 2 - DESCRIPTION, CHECKING AND CONTROL INSTRUMENTS pages).
- To start, turn the ignition switch to position I.
- Press the starter button.
- Do not engage the starter motor for more than 15 seconds and carry out the preheating for 10 seconds between unsuccessful attempts.
- Check all control instruments when the I.C. engine is warm and at regular intervals during use, so as to quickly detect any faults and to be able to correct them without any delay.
- If any faults are displayed on the screen, stop the engine and immediately take the necessary measures.

ELECTRIC PLATFORMS

SAFETY NOTICE

- Do not use the platform if the battery is discharged to the point that movements are slowed down. In certain cases, the platform may stop (see chapter 3 - MAINTENANCE : EVERY DAY OR EVERY 10 HOURS FOR OPERATION pages, for the minimum permissible charge level).

INSTRUCTIONS

- Set the battery cut-out to the ON position.
- Check the closing and locking of the hood(s).
- Turn the ignition key to the basket position.
- Check that everything is operating correctly by ensuring that no error messages are displayed on the screen and that the machine maintenance light is not flashing (see chapter 2 - DESCRIPTION, CHECKING AND CONTROL INSTRUMENTS pages).

NB: For machines not fitted with a display or a maintenance warning light, faults can be identified from the light directly on the variable speed drive unit (to access: open the cowl on the control size, remove the casing from the variable speed drive and see whether the light is flashing).

- If any error messages are constantly displayed or the machine maintenance light is flashing, return the key to the neutral position.
- Set the battery cut-off to the OFF position.
- Immediately take the necessary measures.



F - DRIVING THE PLATFORM

SAFETY NOTICE



Operators should be aware of the risks connected with using the platform, notably:

- Risk of losing control.
 - Risk of losing lateral and frontal stability of the platform.
- The operator must remain in control of the platform.

- Do not carry out operations which exceed the capacities of your platform.
- Familiarise yourself with the platform on the terrain where it will be used.
- Ensure that the brakes work efficiently when stopping a travelling movement, taking into account the braking distances.
- Drive smoothly at an appropriate speed for the operating conditions (land configuration, load in the basket).
- take extreme care if manoeuvring the platform with the basket in the high position. Ensure you have adequate visibility.
- Take bends slowly.
- In all circumstances make sure you are in control of your speed.
- Travel slowly on damp, slippery or uneven terrain or on truck ramps.
- Always remember that the hydraulic form of steering is very sensitive to movements.
- Never leave the I.C. engine on when the platform is unattended.
- Look where you are going and always make sure you have good visibility along the route.
- Drive round obstacles.
- Never drive on the edge of a ditch or steep slope.
- Whatever your travelling speed, you must reduce the speed as much as possible before stopping.
- The lifting platform must work in an obstacle-free area, where there is no danger descending to the ground.
- The operator using the lifting platform must be assisted by an appropriately instructed person on the ground.
- Comply with the limits shown on the lifting platform's load graph.

INSTRUCTIONS

- When moving the platform a long distance, always travel with the arms folded or the scissors in the low position.
- Engage the appropriate gear (see chapter 2 - DESCRIPTION, CHECKING AND CONTROL INSTRUMENTS pages).



G - STOPPING THE PLATFORM

SAFETY NOTICE

- Never leave the ignition key in the platform during the operator's absence.
- Make sure that the platform is not stopped in any position that will interfere with the traffic flow and at less than one meter from the track of a railway.
- In the event of prolonged parking on a site, protect the platform from bad weather, particularly from frost (check the level of antifreeze), close and lock all the platform accesses (cows...).
- Park the lifting platform on a flat surface or on a slight slope of less than 10%.

INSTRUCTIONS

PLATFORMS WITH IC ENGINES

- Before stopping the platform after a long working period, leave the I.C. engine idling for a few moments, to allow the coolant liquid and oil to lower the temperature of the I.C. engine and transmission.



Do not forget this precaution, in the event of frequent stops or warm stalling of the I.C. engine, or else the temperature of certain parts will rise significantly due to the stopping of the cooling system, with the risk of badly damaging such parts.

- Stop the I.C. engine with the ignition switch.
- Remove the ignition key.
- Check that all the accesses on the platform are closed and locked (cows...).

ELECTRIC PLATFORMS

- Remove the ground/platform control selection key.
- Check that all the accesses on the platform are closed and locked (cows...).
- Set the battery cut-out to the OFF position (ELECTRIC PLATFORM).



INSTRUCTIONS FOR WELDING AND BLOW TORCH WORK ON THE EXTERNAL STRUCTURE



Ensure that there are no hydraulic or electrolyte leaks on the platform.



When welding, work in the opposite direction from the control console to avoid sparks damaging it .

- Any welding and cutting (blow torch) work from the basket on a building's metallic structures requires the following precautions to be taken:

A - WITH ELECTRIC WELDING EQUIPMENT

- It is essential that the machine has a discharge braid connecting the platform's chassis to the ground.
- It is also essential that the external structure to be welded is connected to the earth. If the above conditions are observed, the platform can, in this case, be in contact with the structure or the elements to be welded without damaging the electronic components.
- The power supply to the welding equipment must be via an earthed socket and any extension required just also be earthed.
- In all cases, ensure that there are no electrical arcs in the basket or on the platform (contact between the brazing rod or the torch and the welding equipment's earth). To ensure this, at any time the welding equipment's earth must not be positioned on the platform's basket but instead only as close as possible to the element to be welded.
- Switch off the welding equipment before disconnecting the earth clamp from the element or elements to be welded.

B - WITH A BLOW TORCH

- Attach the blow torch's bottles to the basket's handrails.
- instructions for welding and blow torch work on the external structure
- Do not set the blow torch down on the lip of the basket while it is still operating or point it towards the control console or its power cables.



PLATFORM MAINTENANCE INSTRUCTIONS

GENERAL INSTRUCTIONS

- Ensure the area is sufficiently ventilated before starting the platform.
- Wear clothes suitable for the maintenance of the platform, avoid wearing jewellery and loose clothes. Tie and protect your hair, if necessary.
- Stop the I.C. engine before conducting any work on the platform, remove the ignition key and disconnect the "Minus" battery terminal.
- Set the battery cut-out to the OFF position (ELECTRIC PLATFORM).
- Read the operator's manual carefully.
- Carry out all repairs immediately, even if the repairs concerned are minor.
- Repair all leaks immediately, even if the leak concerned is minor.
- Make sure that the disposal of process materials and of spare parts is carried out in total safety and in a ecological way.
- Be careful of the risk of burning and splashing (exhaust, radiator, I.C. engine, etc.).

MAINTENANCE

- Perform the periodic service (see : 3 - MAINTENANCE) to keep your platform in good working conditions. Failure to perform the periodic service may cancel the contractual guarantee.

MAINTENANCE LOG

- The maintenance work performed following the recommendations in Part 3 - MAINTENANCE and the other inspection, servicing, repair and modification work performed on the lifting platform must be recorded in a maintenance log. A note must be made, for each operation, of the date of the work, the names of the persons or companies that have performed them, the nature of the 'operation and, where applicable, the maintenance intervals. When components in the lifting platform have to be replaced, the components' references must be noted.

LUBRICANT AND FUEL LEVELS

- Use the recommended lubricants (never use contaminated lubricants).
- Do not fill the fuel tank when the I.C. engine is running.
- Only fill up the fuel tank in areas specified for this purpose.
- Do not fill the fuel tank to the maximum level.
- Do not smoke or approach the platform with a flame, when the fuel tank is open or is being filled.

LEVEL OF ELECTROLYTE IN THE BATTERY

- Check the level of the battery or batteries.



When doing this, ensure you take all the safety precautions (See : 3 - MAINTENANCE).



HYDRAULIC

- Make any repairs and fix any leaks, including minor ones, immediately.
- Do not attempt to loosen unions, hoses or any hydraulic component with the circuit under pressure.



BALANCING VALVE : It is dangerous to change the setting and remove the balancing valves or safety valves which may be fitted to your platform cylinders. These operations must only be performed by approved personnel (consult your dealer).



Ensure that all consumables and replacement parts are disposed of safely, in an environmentally friendly manner.



The **HYDRAULIC ACCUMULATORS** that can be fitted on your lifting platform are pressurised components; removal of these components and their hoses can be a dangerous operation. It should only be performed by accredited personnel (please contact your dealer).

ELECTRICITY

- Do not drop metallic items on the battery (between the "Plus" and "Minus terminals").
- Disconnect the battery or batteries before working on the electrical circuit.
- The electrical box must only be opened by authorized personnel.

WELDING ON THE ACCESS PLATFORM

- Disconnect the battery or batteries before welding on the platform.
- When carrying out electric welding work on the platform, connect the negative cable from the equipment directly to the part being welded, so as to avoid high tension current passing through the alternator or the live ring.
- If the platform is equipped with an electronic control unit, disconnect this before starting to weld, to avoid the risk of causing irreparable damage to electronic components.



Welding operations on the structure for maintenance or repair operations must only be performed by MANITOU-certified personnel.

WASHING THE PLATFORM

- Clean the platform or at least the area concerned before any intervention.
- Remember to close and lock all accesses to the platform (cowls...).
- When cleaning with a pressure washer, avoid the articulation joints, and the electrical components and connections.
- If necessary, protect components likely to be damaged, and in particular the electrical components (variable speed drive, charger) and connections and the injection pump from penetration by water, steam or cleaning products.
- Dry the electrical components.
- Clean the platform of any fuel, oil or grease trace.
- Grease the shafts.

FOR ANY INTERVENTION OTHER THAN REGULAR MAINTENANCE,
CONSULT YOUR DEALER.



IF THE PLATFORM IS NOT TO BE USED FOR A LONG TIME

INTRODUCTION

The following recommendations are intended to prevent the platform from being damaged when it is withdrawn from service for an extended period.

For these operations, we recommend the use of a MANITOU protective product, reference 603726.

Instructions for using the product are given on the packaging.



Procedures to follow if the platform is not to be used for a long time and for starting it up again afterwards must be performed by your dealership.

PREPARING THE PLATFORM

- Clean the platform thoroughly.
- Check and repair any leakage of fuel, oil, water or air.
- Replace or repair any worn or damaged parts.
- Wash the painted surfaces of the platform in clear and cold water and wipe them.
- Touch up the paintwork if necessary.
- Shut down the platform (see vacuous and in load DRIVING INSTRUCTIONS).
- Make sure the cylinder rods are all in retracted position.
- Release the pressure in the hydraulic circuits.

PROTECTING THE I.C. ENGINE

- Fill the tank with fuel (see : 3 - MAINTENANCE).
- Empty and replace the cooling liquid (see : 3 - MAINTENANCE).
- Leave the I.C. engine running at idling speed for a few minutes, then switch off.
- Replace the I.C. engine oil and oil filter (see : 3 - MAINTENANCE).
- Add the protective product to the engine oil.
- Run the I.C. engine for a short time so that the oil and cooling liquid circulate inside.
- Disconnect the battery and store it in a safe place away from the cold, after charging it to a maximum.
- Remove the injectors and spray the protective product into each cylinder for two seconds with the piston in low neutral position.
- Turn the crankshaft once slowly and refit the injectors (see I.C. engine REPAIR MANUAL).
- Remove the intake hose from the manifold or turbocharger and spray the protective product into the manifold or turbocharger.
- Cap the intake manifold hole with waterproof adhesive tape.
- Remove the exhaust pipe and spray the protective product into the exhaust manifold.
- Refit the exhaust pipe and block the outlet with waterproof adhesive tape.

NB : The spray time is noted on the product packaging.

- Open the filler plug, spray the protective product around the rocker arm shaft and refit the filler plug.
- Cap the fuel tank using waterproof adhesive tape.
- Remove the drive belts and store them in a safe place.
- Disconnect the engine cut-off solenoid on the injection pump and carefully insulate the connection.



CHARGING THE BATTERIES

- In the case of electric platforms, in order to preserve the batteries' life and their capacity, check them periodically and keep the charge level constant (see : 3 - MAINTENANCE).

PROTECTING THE PLATFORM

- Protect cylinder rods which will not be retracted, from corrosion.
- Wrap the tyres.
NB : If the platform is to be stored outdoors, cover it with a waterproof tarpaulin.

BRINGING THE PLATFORM BACK INTO SERVICE

- Remove the waterproof adhesive tape from all the holes.
- Refit the intake hose.
- Reconnect the engine cut-off solenoid.
- Refit and reconnect the battery.
- Remove the protection from the cylinder rods.
- Perform the daily service (see : 3 - MAINTENANCE)
- Empty and replace the fuel and replace the fuel filter (see : 3 - MAINTENANCE).
- Refit and set the tension in the drive belts (see : 3 - MAINTENANCE).
- Turn the I.C. engine using the starter, to allow the oil pressure to rise.
- Lubricate the platform completely (see : 3 - MAINTENANCE, MAINTENANCE TABLE).



Make sure the area is adequately ventilated before starting up the platform.

- Start up the platform, following the safety instructions and regulations (see DRIVING INSTRUCTIONS).
- Carry out all the lifting system's hydraulic movements right up to the limit switches for each cilinder.



SCRAPPING THE NACELLE

MANITOU complies with the regulations issued under the directive 2000/53/CE relating to the end of the life of the nacelle. This nacelle does not contain any substance or material forbidden by the directive 2000/53/CE.

NOTE: Before scrapping the nacelle, consult your dealer.

RECYCLING OF MATERIALS

METALS

- These are 100% recoverable and recyclable.

PLASTIC MATERIALS

- The plastic parts are marked, in accordance with the regulations in force.
- To facilitate the recycling process, the range of materials used has been limited.
- The majority of the plastic materials are made up of thermoplastics which are easily recyclable by melting, granulating or grinding.

RUBBERS

- The tyres and seals can be ground to be used in the manufacture of cement or to create reusable granules.

LENSES

- These can be removed and collected for processing by glass manufacturers.

ENVIRONMENTAL PROTECTION

- If you entrust the maintenance of your nacelle to the MANITOU network, the risk of pollution is limited and the contribution to the protection of the environment is respected.

WORN OR DAMAGED PARTS

- Do not discard parts into the environment.
- MANITOU and its network take an approach that protects the environment through recycling.

WASTE OIL

- The MANITOU ensures that it is collected and treated.
- By entrusting them with your oil changes, the risk of pollution is limited.

WASTE BATTERIES

- Do not throw away any batteries, they contain metals that are harmful to the environment.
- Bring them to the MANITOU network or any other approved collection point.

NOTE: MANITOU's objective is to manufacture nacelle with the best performance and limit polluting emissions.



SAFETY LABELS 160 ATJ E3 - 160 ATJ RC E3 - 160 ATJS E3 - 180 ATJ 2 E3 - 180 ATJ 2 RC E3

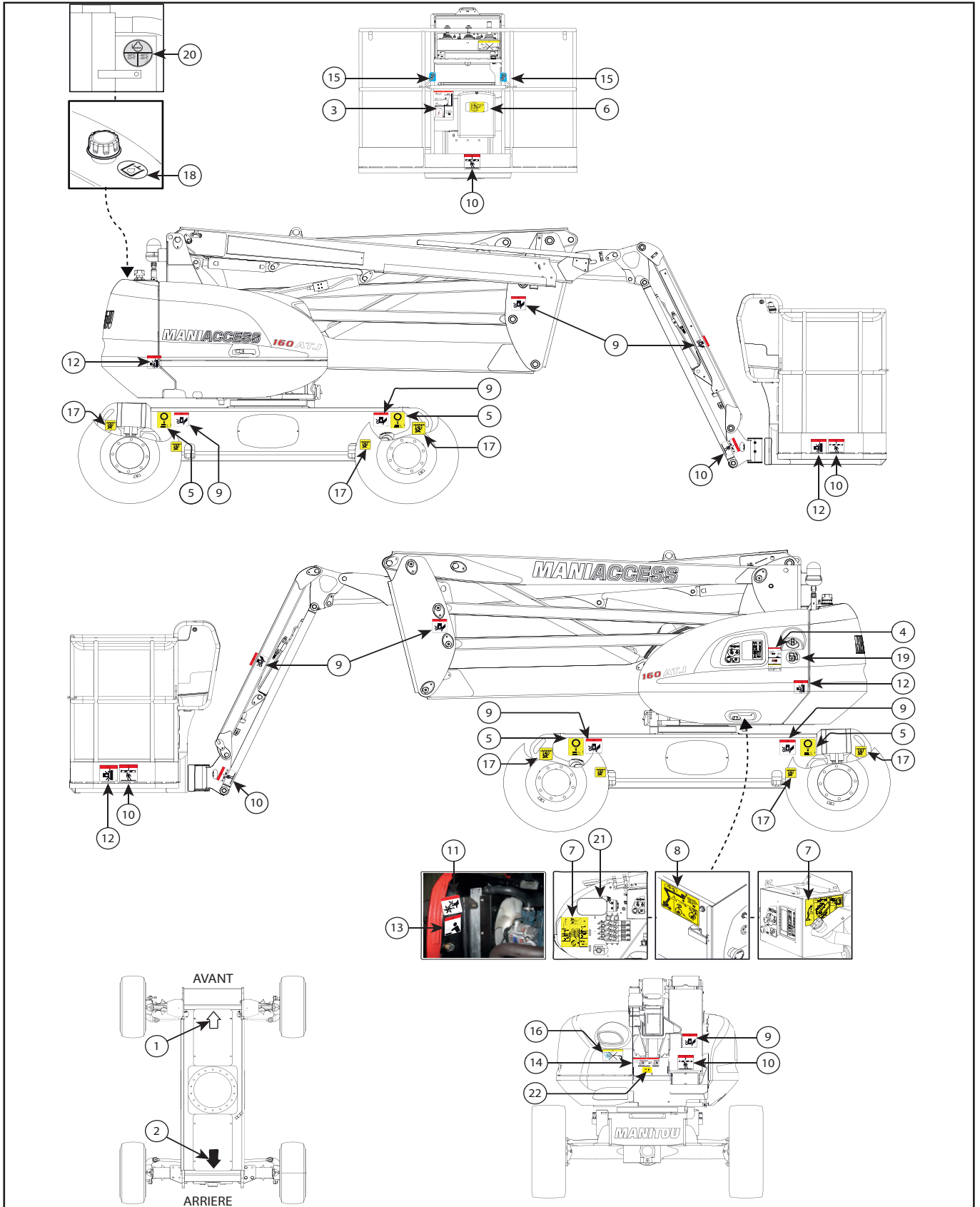



	<u>160 ATJ E3</u>	<u>180 ATJ 2 E3</u>
1 - WHITE ARROW	(REF: 498 327)	1-22
2 - BLACK ARROW	(REF: 498 326)	1-22
3 - BASKET INSTRUCTIONS / LOAD CAPACITY	(REF: 676 814)	1-22
4A - SAFETY INSTRUCTIONS	(REF: 685 608)	1-23
4B - TOWING	(REF: 685 608)	1-23
4C - WASHING RECOMMENDATIONS	(REF: 685 608)	1-23
5 - WHEEL LOAD	(REF: 683963)	(REF: 313819) 1-23
6 - LOCATION OF THE PLATFORM KEY	(REF: 598 897)	1-24
7 - MANUAL CONTROL PROCEDURE	(REF: 831 465 - 833 832)	1-24
8 - EMERGENCY PUMP	(REF: 676 992)	1-24
9 - RISK OF BEING CRUSHED	(REF: 676 988)	1-25
10 - DANGER KEEP AWAY	(REF: 679 450)	1-25
11 - MOVING PART	(REF: 683 108)	1-25
12 - DANGER RISK OF CRUSHING	(REF: 679 452)	1-25
13 - RISK OF BURNS	(REF: 683 112)	1-26
14 - ARM SUPPORT	(REF: 678 424)	1-26
15 - SAFETY ATTACHMENTS	(REF: 834 438)	1-26
16 - RECOMMENDATIONS FOR WASHING	(REF: 313672)	1-26
17 - TIE-DOWN HOOK	(REF: 833 041)	1-27
18 - HYDRAULIC OIL	(REF: 597 652)	1-27
19 - DIESEL	(REF: 683 437)	1-27
20 - ANTI-FREEZE	(REF: 597 649)	1-27
21 - SENSORS AND COIL	(REF: 834 406)	1-27
22 - BATTERY LOCATION	(REF: 525 09 705)	1-27
23 - BURN HAZARD	(REF: 683 109)	1-27
24 - MOVING PART	(REF: 683 108)	1-27
25 - ELECTRICAL SAFETY DISTANCE	(REF: 834 436)	1-27
26 - USING MANITOU TYRES ONLY	(REF: 834 437)	1-27

MEANINGS

1 - WHITE ARROW

This indicates the translation direction when moving forward.



Identify the forward direction by looking at the arrows on the chassis and those on the basket control console.

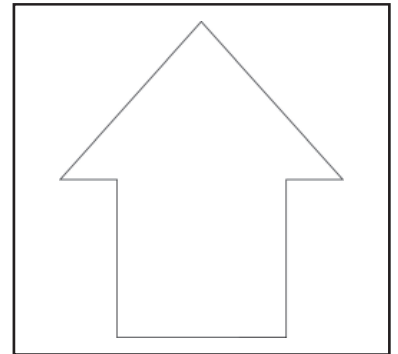

2 - BLACK ARROW

This indicates the translation direction when reversing.



Identify the forward direction by looking at the arrows on the chassis and those on the basket control console.

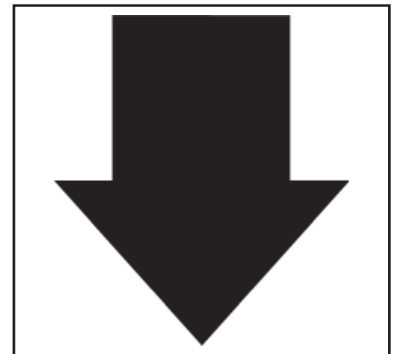

3 - BASKET INSTRUCTIONS AND LOAD CAPACITY

This describes several points:

- The platform's capacity in indoor and outdoor use.
- The risks of electric shocks.
- An invitation to check the instructions for more details on the safety instructions.

NOTE: The capacities are individual to each platform; please refer to this sticker for your own machine.





4A - SAFETY ADVICE

Read and take note of the operating instructions and safety measures before starting the lifting platform.

4B - TOWING

This sticker states that the machine must not be towed if it breaks down.

4C - WASHING RECOMMENDATIONS

It is strictly forbidden to use a pressure washer to clean the control knobs and the electrical components.

5 - WHEEL LOAD

This shows the maximum load that a wheel may exert on the ground (see 2 - DESCRIPTION: CHARACTERISTICS for the value).

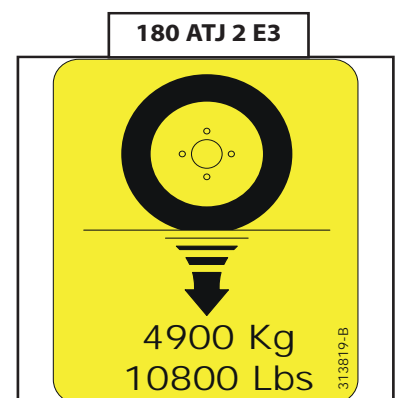
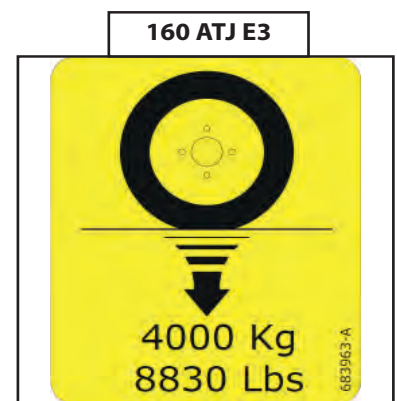
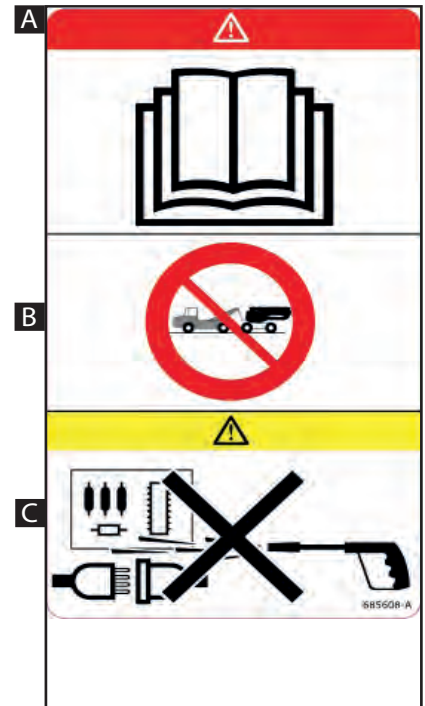



6 - LOCATION OF THE PLATFORM KEY

The duplicate platform keys (ignition, control selection, cover-opening keys...) are stored in this location specially provided.

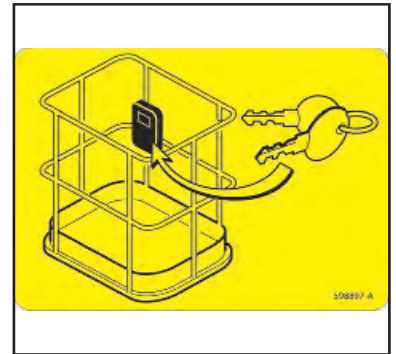

7 - MANUAL CONTROL PROCEDURE

This describes the procedure for performing movements with the emergency pump and the manual controls when an accident or breakdown occurs that makes the electrical control box inoperative. Operate ... (see the description in SECTION 2).

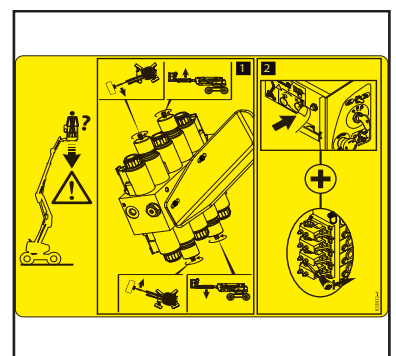
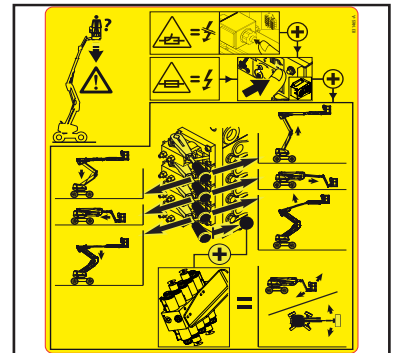

8 - EMERGENCY PUMP

The emergency pump must only be used in the event of a problem or breakdown occurring. It must not be used for longer than 4 minutes in every 10-minute period.

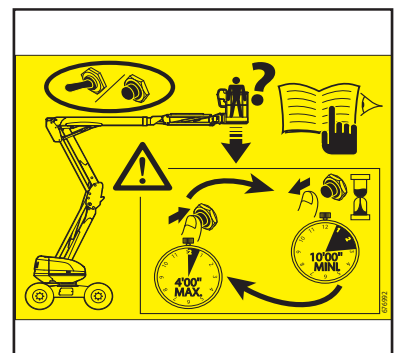

9. RISK OF BEING CRUSHED

It is strictly forbidden to insert your fingers, or any other part of your body, in the lifting structure's components (arms, scissors, pendular arm, etc.); there is a risk of being crushed.



10 - DANGER, KEEP AWAY

It is strictly forbidden to walk under or park under the structure (arms, scissors, jib-mounted platform, basket...) and in the lifting platform's operating area.



11- MOVING PART

This sticker shows the hazard relating to locating hands or fingers at this place; cutting of fingers in the blades of the cooling fan.



12 - DANGER OF BEING CRUSHED

It is strictly forbidden to park in this area when the lifting platform is moving (translation, rotation, etc.). The components to which the stickers are attached could hit you; there is a risk of your being crushed.



13 - RISK OF BURNS

This sticker indicates that there is a significant risk of your being burnt in this region (engine silencer, IC engine, etc.).



14 - ARM SUPPORT

This sticker informs you of the use of a maintenance support when working on the lifting platform in operating position.

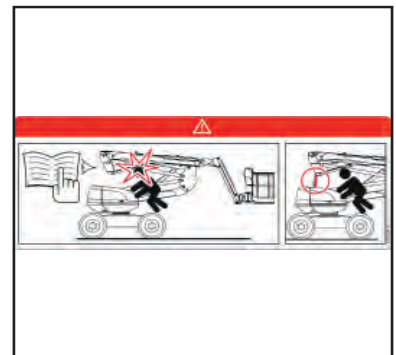

15- SAFETY ATTACHMENTS

This sticker shows where the safety harness should be attached and the number of people that can use it.



16 - RECOMMENDATIONS FOR WASHING

This adhesive indicates that water must not be splashed on the mouth of the air filter or on the electrical components.

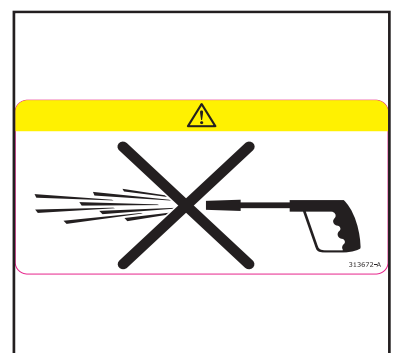

17 - TIE-DOWN HOOK

This sticker shows the location of the anchoring points for tying the platform on a lorry bed.
(see 3 – OCCASIONAL MAINTENANCE).



18 - HYDRAULIC OIL

This indicates that this reservoir is designed only to hold hydraulic oil.
NB: see MAINTENANCE: LUBRICANTS



19 - DIESEL

This indicates that this reservoir is designed only to hold fuel for diesel vehicles.



20 - ANTI-FREEZE

This sticker indicates that there is anti-freeze in the engine.
When protection is provided by anti-freeze with properties differing from the original, the -30° or -40°C box must be ticked.

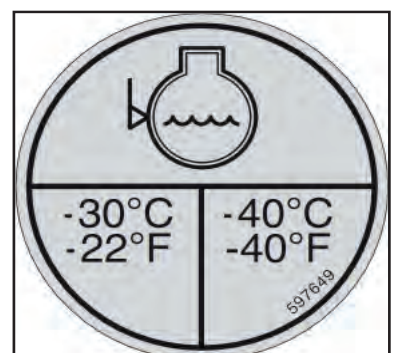



21 - SENSORS AND COILS

This adhesive shows the fault codes and the location of the electrical components, such as sensors (DS, AS, IS), the solenoid valves (EV) and the solenoid coils (EW).

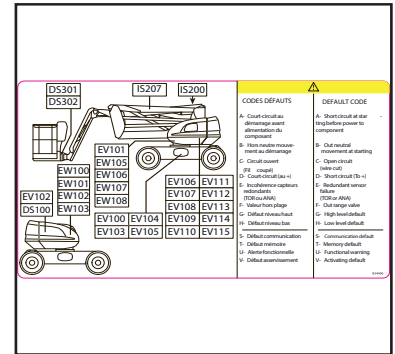

22 - BATTERY SYMBOL

This sticker shows the location of the battery.

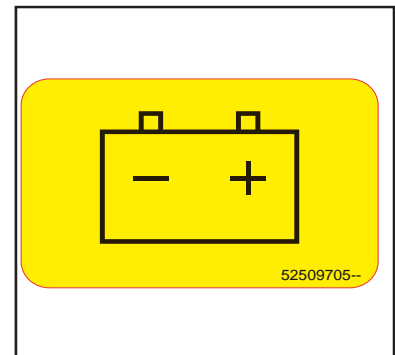



23 - BURN HARZARD

This sticker shows the hazard relating of spraying or burning when removing the cooling circuit filter plug.



24 - MOVING PART

This sticker shows the hazard relating to locating hands or fingers at this place; cutting of fingers in the blades of the cooling fan.



25 - ELECTRICAL SAFETY DISTANCE

This sticker shows the different areas for operating with elevating work platforms near power lines.

Clearance Requirements for Operating Non-Insulated Mobile Plant Including Elevating Work Platforms Near Power Lines While in Operating Mode

Overhead Power Lines on Poles	Special Provisions	Overhead Power Lines on Towers
<p>NO GO ZONE</p> <p>For the platform or the person located on the platform</p> <p>System Voltage: 110V, 220V, 230V, 240V, 250V, 270V, 330V, 345V, 360V, 380V, 400V, 415V, 440V, 480V, 500V, 525V, 550V, 600V, 690V, 720V, 762V, 800V, 825V, 860V, 900V, 950V, 1000V, 1150V, 1200V, 1380V, 1470V, 1500V, 1610V, 1650V, 1700V, 1750V, 1800V, 1990V, 2000V, 2100V, 2200V, 2300V, 2400V, 2500V, 2600V, 2700V, 2800V, 2900V, 3000V, 3300V, 3450V, 3600V, 3800V, 4000V, 4150V, 4400V, 4800V, 5000V, 5250V, 5500V, 6000V, 6900V, 7200V, 7620V, 8000V, 8250V, 8600V, 9000V, 9500V, 10000V, 11500V, 12000V, 13800V, 14700V, 15000V, 16100V, 16500V, 17000V, 17500V, 18000V, 19900V, 20000V, 21000V, 22000V, 23000V, 24000V, 25000V, 26000V, 27000V, 28000V, 29000V, 30000V, 33000V, 34500V, 36000V, 38000V, 40000V, 41500V, 44000V, 48000V, 50000V, 52500V, 55000V, 60000V, 69000V, 72000V, 76200V, 80000V, 82500V, 86000V, 90000V, 95000V, 100000V</p> <p>Special Provisions:</p> <ul style="list-style-type: none"> No.1: Notify the power authority before commencing work. No.2: Obtain written permission from the power authority. No.3: DO NOT commence work until a pre-start safety meeting and a risk assessment have been completed. <p>Note: The term "operator" is defined as a safety observer who is a person responsible for the safe task of clearing and working against unsafe approach to overhead power lines and other electrical equipment.</p> <p>These special provisions are not applicable to workers in or engaged by companies in the electricity supply industry.</p> <p>Note: If the boom is insulated and has a current test certificate issued by a NATA approved laboratory, its spots is required in the yellow area. The 3.0m clearance is from the top of the bucket of the elevating work platform.</p>	<p>For Operating Elevating Work Platforms Seeking to Operate in the NO GO Zone:</p> <ul style="list-style-type: none"> No.1: Notify the power authority before commencing work. No.2: Obtain written permission from the power authority. No.3: DO NOT commence work until a pre-start safety meeting and a risk assessment have been completed. <p>The term "operator" is defined as a safety observer who is a person responsible for the safe task of clearing and working against unsafe approach to overhead power lines and other electrical equipment.</p> <p>Note: These special provisions are not applicable to workers in or engaged by companies in the electricity supply industry.</p>	<p>NO GO ZONE</p> <p>For the platform or the person located on the platform</p> <p>System Voltage: 110V, 220V, 230V, 240V, 250V, 270V, 330V, 345V, 360V, 380V, 400V, 415V, 440V, 480V, 500V, 525V, 550V, 600V, 690V, 720V, 762V, 800V, 825V, 860V, 900V, 950V, 1000V, 1150V, 1200V, 1380V, 1470V, 1500V, 1610V, 1650V, 1700V, 1750V, 1800V, 1990V, 2000V, 2100V, 2200V, 2300V, 2400V, 2500V, 2600V, 2700V, 2800V, 2900V, 3000V, 3300V, 3450V, 3600V, 3800V, 4000V, 4150V, 4400V, 4800V, 5000V, 5250V, 5500V, 6000V, 6900V, 7200V, 7620V, 8000V, 8250V, 8600V, 9000V, 9500V, 10000V, 11500V, 12000V, 13800V, 14700V, 15000V, 16100V, 16500V, 17000V, 17500V, 18000V, 19900V, 20000V, 21000V, 22000V, 23000V, 24000V, 25000V, 26000V, 27000V, 28000V, 29000V, 30000V, 33000V, 34500V, 36000V, 38000V, 40000V, 41500V, 44000V, 48000V, 50000V, 52500V, 55000V, 60000V, 69000V, 72000V, 76200V, 80000V, 82500V, 86000V, 90000V, 95000V, 100000V</p> <p>Special Provisions:</p> <ul style="list-style-type: none"> No.1: Notify the power authority before commencing work. No.2: Obtain written permission from the power authority. No.3: DO NOT commence work until a pre-start safety meeting and a risk assessment have been completed. <p>Note: The term "operator" is defined as a safety observer who is a person responsible for the safe task of clearing and working against unsafe approach to overhead power lines and other electrical equipment.</p> <p>These special provisions are not applicable to workers in or engaged by companies in the electricity supply industry.</p>

26 - Use MANITOU TYRES ONLY

This sticker indicates that the operator must use the tyres defined by Manitou.

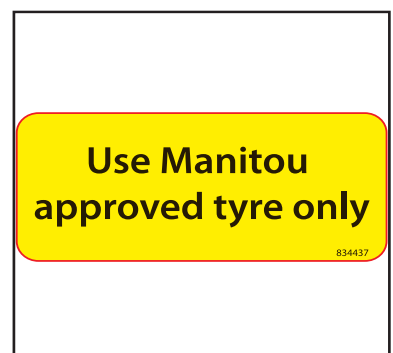





2 - DESCRIPTION





CONTENTS

"CE" CONFORMITY DECLARATION - 160 ATJ E3 AND 160 ATJS E3	2-4
"CE" CONFORMITY DECLARATION- 180 ATJ 2 E3 AND 180 ATJ 2 E3 RC	2-6
REPORT ON MOBILE PERSONNEL LIFTING PLATFORM TESTS	2-8
LIFTING PLATFORM ID	2-10
CHARACTERISTICS 160 ATJ E3 - 160 ATJ E3 RC - 160 ATJS E3	2-12
CHARACTERISTICS 180 ATJ 2 E3 & 180 ATJ 2 E3 RC	2-16
SPACE OCCUPIED 160 ATJ E3 - 160 ATJ E3 RC	2-20
SPACE OCCUPIED 160 ATJS E3	2-21
SPACE OCCUPIED 180 ATJ 2 E3 & 180 ATJ 2 E3 RC	2-22
DIAGRAM 160 ATJ E3 - 160 ATJ E3 RC - 160 ATJS E3	2-24
DIAGRAM 180 ATJ 2 E3 - 180 ATJ 2 E3 RC	2-25
LIFTING PLATFORM OPERATION	2-26
BASE CONTROLS	2-28
BASKET CONTROLS	2-30
EMERGENCY AND GROUND MAINTENANCE STATION	2-32
BASKET CONTROL STATION	2-39
SCREEN DISPLAY – PAGE DESCRIPTIONS	2-48
DESCRIPTION OF THE SUB-MENUS	2-50
HOW TO USE THE LIFTING PLATFORM	2-52
RESCUE PROCEDURE	2-57
DESCRIPTION AND USE OF THE OPTIONS	2-62



«EC» DECLARATION OF CONFORMITY - 160 ATJ E3 ET 160 ATJS E3

• UP TO THE LIFTING PLATFORM No. 951 457 EXCEPT LIFTING PLATFORM No. 950 552

- 1) **DÉCLARATION «CE» DE CONFORMITÉ (originale)**
« EC » DECLARATION OF CONFORMITY (original)
- 2) La société, *The company* : MANITOU BF
- 3) Adresse, *Address* : 430, rue de l'Aubinière - BP 10249 - 44158 - ANCENIS CEDEX - FRANCE
- 4) Dossier technique, *Technical file* : MANITOU BF - 430, rue de l'Aubinière
BP 10249 - 44158 - ANCENIS CEDEX - FRANCE
- 5) Constructeur de la machine décrite ci-après, *Manufacturer of the machine described below* :
160 ATJ E3 et 160 ATJS E3
- 6) Déclare que cette machine, *Declares that this machine* :
- 7) Est conforme aux directives suivantes et à leurs transpositions en droit national, *Complies with the following directives and their transpositions into national law* :
2006/42/CE
8) Pour les machines annexe IV , *For annex IV machines* :
9) Numéro d'attestation, *Certificate number* : 0526 5179 760 10 11 4965
10) Organisme notifié, *Notified body* : CETIM NB N° 0526
52 avenue Felix Louat - BP 80067
60304 SENLIS CEDEX FRANCE
2000/14/CE + 2005/88/CE
11) Numéro d'attestation, *Certificate number* :
10) Organisme notifié, *Notified body* :
12) Niveau de puissance acoustique, *Sound power level* :
13) Mesuré, *Measured* : 101,61 dB (A)
14) Garanti, *Guaranteed* : 102 dB (A)
2004/108/CE
11) Numéro d'attestation, *Certificate number* :
10) Organisme notifié, *Notified body* :
- 15) Normes harmonisées utilisées, *Harmonised standards used* : EN12895
- 16) Normes ou dispositions techniques utilisées, *Standards or technical provisions used* :
- 17) Fait à, *Done at* : Ancenis 18) Date, *Date* : 12/10/2011
- 19) Nom du signataire, *Name of signatory* : Eric LAMBERT
- 20) Fonction, *Function* : Président division RTH
- 21) Signature, *Signature* :



- bg :** 1) удостоверение за « CE » съответствие (оригинална), 2) Фирмата, 3) Адрес, 4) Техническо досие, 5) Фабрикант на описаната по-долу машина, 6) Обявява, че тази машина, 7) Отговаря на следните директиви и на тяхното съответствие национално право, 8) За машините към допълнение IV, 9) Номер на удостоверението, 10) Наименувана фирма, 15) хармонизирани стандарти използвани, 16) стандарти или технически правила, използвани, 17) Изработено в, 18) Дата, 19) Име на разпасаля се, 20) Функция, 21) Функция.
- cs :** 1) ES prohlášení o shodě (původní), 2) Název společnosti, 3) Adresa, 4) Technická dokumentace, 5) Výrobce níže uvedeného stroje, 6) Prohlašuje, že tento stroj, 7) Je v souladu s následujícími směrnicemi a směrnici transponovanými do vnitrostátního práva, 8) Pro stroje v příloze IV, 9) Číslo certifikátu, 10) Notifikační orgán, 15) harmonizované normy použity, 16) Norem a technických pravidel používaných, 17) Místo vydání, 18) Datum vydání, 19) Jméno podepsaného, 20) Funkce, 21) Podpis.
- da :** 1) EF Overensstemmelseerklæring (original), 2) Firmaet, 3) Adresse, 4) tekniske dossier, 5) Konstruktør af nedenfor beskrevne maskine, 6) Erklærer, at denne maskine, 7) Overholder nedennævnte direktiver og disses gennemførelse til national ret, 8) For maskiner under bilag IV, 9) Certifikat nummer, 10) Bemyndigede organ, 15) harmoniserede standarder, der anvendes, 16) standarder eller tekniske regler, 17) Udfærdiget i, 18) Dato, 19) Underskrivers navn, 20) Funktion, 21) Underskrift.
- de :** 1) EG-Konformitätserklärung (original), 2) Die Firma, 3) Adresse, 4) Technischen Unterlagen, 5) Hersteller der nachfolgend beschriebenen Maschine, 6) Erklärt, dass diese Maschine, 7) den folgenden Richtlinien und deren Umsetzung in die nationale Gesetzgebung entspricht, 8) Für die Maschinen laut Anhang IV, 9) Bescheinigungsnummer, 10) Benannte Stelle, 15) angewandten harmonisierten Normen, 16) angewandten sonstigen technischen Normen und Spezifikationen, 17) Ausgestellt in, 18) Datum, 19) Name des Unterzeichners, 20) Funktion, 21) Unterschrift.
- el :** 1) Δήλωση συμμόρφωσης CE (πρωτότυπο), 2) Η εταιρεία, 3) Διεύθυνση, 4) τεχνικό φάκελο, 5) Κατασκευάστρια του εξής περιγραφόμενου μηχανήματος, 6) Δηλώνει ότι αυτό το μηχάνημα, 7) Είναι σύμφωνο με τις εξής οδηγίες και τις προσαρμογές τους στο εθνικό δίκαιο, 8) Για τα μηχανήματα παραρτήματος IV, 9) Αριθμός δήλωσης, 10) Κοινοποιημένος φορέας, 15) εναρμονισμένα πρότυπα που χρησιμοποιούνται, 16) Πρότυπα ή τεχνικούς κανόνες που χρησιμοποιούνται, 16) Είναι σύμφωνο με τα εξής πρότυπα και τεχνικές διατάξεις, 17) Εν, 18) Ημερομηνία, 19) Όνομα του υπογράφοντος, 20) Θέση, 21) Υπογραφή.
- es :** 1) Declaración DE de conformidad (original), 2) La sociedad, 3) Dirección, 4) expediente técnico, 5) Constructor de la máquina descrita a continuación, 6) Declara que esta máquina, 7) Está conforme a las siguientes directivas y a sus transposiciones en derecho nacional, 8) Para las máquinas anexo IV, 9) Número de certificación, 10) Organismo notificado, 15) normas armonizadas utilizadas, 16) Otras normas o especificaciones técnicas utilizadas, 17) Hecho en, 18) Fecha, 19) Nombre del signatario, 20) Función, 21) Firma.
- et :** 1) EÜ vastavusdeklaratsioon (algupärane), 2) Äriühing, 3) Aadress, 4) Tehniline dokumentatsioon, 5) Seadme tootja, 6) Kinnitab, et see toode, 7) On vastavuses järgmiste direktiivide ja nende riigisisese õigussesse ülevõetmiseks vastuvõetud õigusaktidega, 8) IV lisas loetletud seadmete puhul, 9) Tunnistuse number, 10) Sertifitseerimisasutus, 15) kasutatud üllustatud standardite, 16) Muud standardites või spetsifikatsioonides kasutatakse, 17) Väljaandmise koht, 18) Väljaandmise aeg, 19) Allkirjastaja nimi, 20) Amet, 21) Allkiri.
- fi :** 1) EY-vaatimustenmukaisuusvakuutus (alkuperäiset), 2) Yritys, 3) Osoite, 4) teknisen eritelmän, 5) Jäljessä kuvatun koneen valmistaja, 6) Vakuuttaa, että tämä kone, 7) Täyttää seuraavien direktiivien sekä niitä vastaavien kansallisten säännösten vaatimukset, 8) Liitteen IV koneiden osalta, 9) Todistuksen numero, 10) Ilmoitettu laitos, 15) yhdenmukaistettuja standardeja käytetään, 16) muita standardeja tai eritelmät, 17) Paikka, 18) Aika, 19) Allekirjoittajan nimi, 20) Toimi, 21) Allekirjoitus.
- ga :** 1) « EC » dearbhú comhréachta (bunaidh), 2) An comhlacht, 3) Seoladh, 4) comhad teicniúil, 5) Déantóir an innill a thuairiscítear thíos, 6) Dearbháionn sé go bhfuil an inneall, 7) Go gclóíonn sé le na treoracha seo a leanas agus a trasúilim isteach i ndlí náisiúnta, 8) Le haghaidh innill an aguisín IV, 9) Uimhir teastais, 10) Comhlacht a chuireadh i bhfios, 15) caighdeáin comhchuíbhithe a úsáidtear, 16) caighdeáin eile nó sonraíochtaí teicniúla a úsáidtear, 17) Déanta ag, 18) Dáta, 19) Ainm an tsínitheora, 20) Feidhm, 21) Síniú.
- hu :** 1) CE megfelelősigi nyilatkozat (eredeti), 2) A vállalat, 3) Cím, 4) műszaki dokumentáció, 5) Az alábbi gép gyártója, 6) Kijelenti, hogy a gép, 7) Megfelel az alábbi irányelveknek valamint azok honosított előírásainak, 8) A IV. melléklet gépeihez, 9) Bizonylati szám, 10) Értesített szervezet, 15) felhasznált harmonizált szabványok, 16) egyéb felhasznált műszaki szabványok és előírások hivatkozásai, 17) Kelt (hely), 18) Dátum, 19) Aláíró neve, 20) Funkció, 21) Aláírás.
- is :** 1) (Samræmisvottorð ESB (upprunalega), 2) Fyrirtækið, 3) Aðsetur, 4) Tæknilegar skrá, 5) Smíður tækisins sem lýst er hér á eftir, 6) Staðfestir að tækið, 7) Samræmist eftirfarandi stöðlum og staðfarlu þeirra með hljóðin af þjóðarrétti, 8) Fyrir tækin í aukakafli IV, 9) Staðfestingarnúmer, 10) Tilkynt til, 15) samhæfða staðla sem notaðir, 16) önnur staðlar eða forskrifir notað, 17) Staður, 18) Dagsetning, 19) Nafn undirritaðs, 20) Staða, 21) Undirskrift.
- it :** 1) Dichiarazione CE di conformità (originale), 2) La società, 3) Indirizzo, 4) fascicolo tecnico, 5) Costruttore della macchina descritta di seguito, 6) Dichiaro che questa macchina, 7) È conforme alle direttive seguenti e alle relative trasposizioni nel diritto nazionale, 8) Per le macchine Allegato IV, 9) Numero di Attestazione, 10) Organismo notificato, 15) norme armonizzate applicate, 16) altre norme e specifiche tecniche applicate, 17) Stabilità a, 18) Data, 19) Nome del firmatario, 20) Funzione, 21) Firma.
- lt :** 1) CE atitikties deklaracija (originalas), 2) Bendrovė, 3) Adresas, 4) Techninė byla, 5) Žemiau nurodytas įrenginio gamintojas, 6) Pareiškia, kad šis įrenginys, 7) Atitinka toliau nurodytas direktyvas ir į nacionalinius teisės aktus perkeltas jų nuostatas, 8) IV priedas dėl mašinų, 9) Sertifikato Nr., 10) Paskelbtųjų įstaiga, 15) suderintus standartus naudojamus, 16) Kiti standartai ir techninės specifikacijos, 17) Pasirašyta, 18) Data, 19) Pasirašiusio asmens vardas ir pavardė, 20) Pareigos, 21) Parašas.
- lv :** 1) EK atbilstības deklarācija (oriģināls), 2) Uzņēmums, 3) Adrese, 4) tehniskās lietas, 5) Tālāk aprakstītās iekārtas ražotājs, 6) Apliecinā, ka šī iekārta, 7) Ir atbilstoša tālāk norādītajām direktīvām un to transpozīcijai nacionālajā likumdošanā, 8) Iekārtām IV pielikumā, 9) Apliecinābas numurs, 10) Reģistrētā organizācija, 15) lietotajiem saskaņotajiem standartiem, 16) lietotajiem tehniskajiem standartiem un specifikācijām, 17) Sastādīts, 18) Datums, 19) Parakstītāja vārds, 20) Amats, 21) Paraksts.
- mt :** 1) Dikjarazzjoni ta' Konformità KE (originali), 2) Il-kumpanija, 3) Indirizz, 4) fajl tekniku, 5) Manifattrici tal-magna deskritta hawn isfel, 6) Tiddikjara li din il-magna, 7) Hija konformi hija konformi mad-Direttivi segwenti u l-Igijiet li jimplimentawhom fil-ligi nazjonal, 8) Għall-magni fl-Anness IV, 9) Numru taċ-certifikat, 10) Entità notifikata, 15) l-istandards armonizzati użati, 16) standards tekniċi u specifikazzjonijiet oħra użati, 17) Magħmul f, 18) Data, 19) Isem il-firmatarju, 20) Kariga, 21) Firma.
- nl :** 1) EG-verklaring van overeenstemming (oorspronkelijk), 2) Het bedrijf, 3) Adres, 4) technisch dossier, 5) Constructeur van de hierna genoemde machine, 6) Verklaart dat deze machine, 7) In overeenstemming is met de volgende richtlijnen en hun omzettingen in het nationale recht, 8) Voor machines van bijlage IV, 9) Goedkeuringsnummer, 10) Aangezegde instelling, 15) gehanteerde geharmoniseerde normen, 16) andere gehanteerde technische normen en specificaties, 17) Opgemaakt te, 18) Datum, 19) Naam van ondergetekende, 20) Functie, 21) Handtekening.
- no :** 1) CE-samsvarserklæring (original), 2) Selskapet, 3) Adresse, 4) tekniske arkiv, 5) Fabrikant av følgende maskin, 6) Erklærer at denne maskinen, 7) Oppfyller kravene i følgende direktiver, med nasjonale gjennomføringsbestemmelser, 8) For maskinene i tillegg IV, 9) Attestnummer, 10) Notifisert organ, 15) harmoniserte standarder som brukes, 16) Andre standarder og spesifikasjoner brukt, 17) Utstedt i, 18) Dato, 19) Underskriverens navn, 20) Stilling, 21) Underskrift.
- pl :** 1) Deklaracja zgodności CE (oryginalne), 2) Spółka, 3) Adres, 4) dokumentacji technicznej, 5) Wykonawca maszyny opisanej poniżej, 6) Oświadcza, że ta maszyna, 7) Jest zgodna z następującymi dyrektywami i odpowiadającymi przepisami prawa krajowego, 8) Dla maszyn załącznik IV, 9) Numer certyfikatu, 10) Jednostka certyfikująca, 15) zastosowanych norm zharmonizowanych, 16) innych zastosowanych norm technicznych i specyfikacji, 17) Sporządzono w, 18) Data, 19) Nazwisko podpisującego, 20) Stanowisko, 21) Podpis.
- pt :** 1) Declaração de conformidade CE (original), 2) A empresa, 3) Morada, 4) processo técnico, 5) Fabricante da máquina descrita abaixo, 6) Declara que esta máquina, 7) Está em conformidade às diretivas seguintes e às suas transposições para o direito nacional, 8) Para as máquinas no anexo IV, 9) Número de certificado, 10) Entidade notificada, 15) normas harmonizadas utilizadas, 16) outras normas e especificações técnicas utilizadas, 17) Elaborado em, 18) Data, 19) Nome do signatário, 20) Cargo, 21) Assinatura.
- ro :** 1) Declarație de conformitate CE (originală), 2) Societatea, 3) Adresa, 4) cârții tehnice, 5) Constructor al mașinii descrise mai jos, 6) Declară că prezenta mașină, 7) Este conformă cu directivele următoare și cu transpunerea lor în dreptul național, 8) Pentru mașinile din anexa IV, 9) Număr de atestare, 10) Organism notificat, 15) standardele armonizate utilizate, 16) alte standarde și specificații tehnice utilizate, 17) Întocmit la, 18) Data, 19) Numele persoanei care semnează, 20) Funcția, 21) Semnătura.
- sk :** 1) ES vyhlásenie o zhode (pôvodný), 2) Názov spoločnosti, 3) Adresa, 4) technickej dokumentácie, 5) Výrobca nižšie opísaného stroja, 6) Vyhlasuje, že tento stroj, 7) Je v súlade s nasledujúcimi smernicami a smernicami transponovanými do vnútroštátneho práva, 8) Pre stroje v prílohe IV, 9) Číslo certifikátu, 10) Notifikačný orgán, 15) použité harmonizované normy, 16) použité iné technické normy a predpisy, 17) Miesto vydania, 18) Dátum vydania, 19) Meno podpisujúceho, 20) Funkcia, 21) Podpis.
- sl :** 1) ES Izjava o ustreznosti (izvirna), 2) Družba, 3) Naslov, 4) tehnične dokumentacije, 5) Proizvajalac tukaj opisanega stroja, 6) Izjavlja, da je ta stroj, 7) Ustreza naslednjim direktivam in njihovi transpoziciji v državno pravo, 8) Za stroje priloga IV, 9) Številka potrdila, 10) Obvestilo organu, 15) uporabljene harmonizirane standarde, 16) druge uporabljene tehnične standarde in zahteve, 17) V, 18) Datum, 19) Ime podpisnika, 20) Funkcija, 21) Podpis.
- sv :** 1) CE-försäkran om överensstämmelse (original), 2) Företaget, 3) Adress, 4) tekniska dokumentationen, 5) Konstruktör av nedan beskrivna maskin, 6) Försäkrar att denna maskin, 7) Överensstämmer med nedanstående direktiv och införlivandet av dem i nationell rätt, 8) För maskinerna i bilaga IV, 9) Nummer för godkännande, 10) Organism som underrättats, 15) Harmoniserade standarder som använts, 16) andra tekniska standarder och specifikationer som använts, 17) Upprättat i, 18) Datum, 19) Namn på den som undertecknat, 20) Befattning, 21) Namnteckning.



«EC» DECLARATION OF CONFORMITY - 160 ATJ E3

• FROM THE LIFTING PLATFORM No. 951 458 AND LIFTING PLATFORM No. 950 552

1) **DÉCLARATION «CE» DE CONFORMITÉ (originale)**
« EC » DECLARATION OF CONFORMITY (original)

2) La société, **The company** : MANITOU BF

3) Adresse, **Address** : 430, rue de l'Aubinière - BP 10249 - 44158 - ANCENIS CEDEX - FRANCE

4) Dossier technique, **Technical file** : MANITOU BF - 430, rue de l'Aubinière
BP 10249 - 44158 - ANCENIS CEDEX - FRANCE

5) Constructeur de la machine décrite ci-après, **Manufacturer of the machine described below** :

160 ATJ E3

6) Déclare que cette machine, **Declares that this machine** :

7) Est conforme aux directives suivantes et à leurs transpositions en droit national, **Complies with the following directives and their transpositions into national law** :

2006/42/CE

8) Pour les machines annexe IV , **For annex IV machines** :

9) Numéro d'attestation, **Certificate number** : 0062 5131 760 04 15 0313

10) Organisme notifié, **Notified body** : VERITAS

61/71 Boulevard du Château

92 571 NEUILLY SUR SEINE FRANCE

2000/14/CE + 2005/88/CE

11) Numéro d'attestation, **Certificate number** :

10) Organisme notifié, **Notified body** :

12) Niveau de puissance acoustique, **Sound power level** :

13) Mesuré, **Measured** : 101,61 dB (A)

14) Garanti, **Guaranteed** : 102 dB (A)

2004/108/CE

11) Numéro d'attestation, **Certificate number** :

10) Organisme notifié, **Notified body** :

15) Normes harmonisées utilisées, **Harmonised standards used** : EN12895

16) Normes ou dispositions techniques utilisées, **Standards or technical provisions used** :

17) Fait à, **Done at** : Ancenis

18) Date, **Date** :

19) Nom du signataire, **Name of signatory** : Fernand MIRA

20) Fonction, **Function** : Président division MHA

21) Signature, **Signature** :



- bg :** 1) удостоверение за « CE » съответствие (оригинална), 2) Фирмата, 3) Адрес, 4) Техническо досие, 5) Фабрикант на описаната по-долу машина, 6) Обявява, че тази машина, 7) Отговаря на следните директиви и на тяхното съответствие национално право, 8) За машините към допълнение IV, 9) Номер на удостоверението, 10) Наименувана фирма, 15) хармонизирани стандарти използвани, 16) стандарти или технически правила, използвани, 17) Изработено в, 18) Дата, 19) Име на разписалия се, 20) Функция, 21) Функция.
- cs :** 1) ES prohlášení o shodě (původní), 2) Název společnosti, 3) Adresa, 4) Technická dokumentace, 5) Výrobce níže uvedeného stroje, 6) Prohlašuje, že tento stroj, 7) Je v souladu s následujícími směrnici a s směrnici transponovanými do vnitrostátního práva, 8) Pro stroje v příloze IV, 9) Číslo certifikátu, 10) Notifikační orgán, 15) harmonizované normy použity, 16) Norem a technických pravidel používaných, 17) Místo vydání, 18) Datum vydání, 19) Jméno podepsaného, 20) Funkce, 21) Podpis.
- da :** 1) EF Overensstemmelseerklæring (original), 2) Firmaet, 3) Adresse, 4) tekniske dossier, 5) Konstruktør af nedenfor beskrevne maskine, 6) Erklærer, at denne maskine, 7) Overholder nedennævnte direktiver og disses gennemførelse til national ret, 8) For maskiner under bilag IV, 9) Certifikat nummer, 10) Bemyndigede organ, 15) harmoniserede standarder, der anvendes, 16) standarder eller tekniske regler, 17) Udfærdiget i, 18) Dato, 19) Underskrivers navn, 20) Funktion, 21) Underskrift.
- de :** 1) EG-Konformitätserklärung (original), 2) Die Firma, 3) Adresse, 4) Technischen Unterlagen, 5) Hersteller der nachfolgend beschriebenen Maschine, 6) Erklärt, dass diese Maschine, 7) den folgenden Richtlinien und deren Umsetzung in die nationale Gesetzgebung entspricht, 8) Für die Maschinen laut Anhang IV, 9) Bescheinigungsnummer, 10) Benannte Stelle, 15) angewandten harmonisierten Normen, 16) angewandten sonstigen technischen Normen und Spezifikationen, 17) Ausgestellt in, 18) Datum, 19) Name des Unterzeichners, 20) Funktion, 21) Unterschrift.
- el :** 1) Δήλωση συμμόρφωσης CE (πρωτότυπο), 2) Η εταιρεία, 3) Διεύθυνση, 4) τεχνικό φάκελο, 5) Κατασκευάστρια του εξής περιγραφόμενου μηχανήματος, 6) Δηλώνει ότι αυτό το μηχάνημα, 7) Είναι σύμφωνο με τις εξής οδηγίες και τις προσαρμογές τους στο εθνικό δίκαιο, 8) Για τα μηχανήματα παραρτήματος IV, 9) Αριθμός δήλωσης, 10) Κοινοποιημένος φορέας, 15) εναρμονισμένα πρότυπα που χρησιμοποιούνται, 16) Πρότυπα ή τεχνικούς κανόνες που χρησιμοποιούνται, 16) Είναι σύμφωνο με τα εξής πρότυπα και τεχνικές διατάξεις, 17) Εν, 18) Ημερομηνία, 19) Ονομα του υπογράφοντος, 20) Θέση, 21) Υπογραφή.
- es :** 1) Declaración DE de conformidad (original), 2) La sociedad, 3) Dirección, 4) expediente técnico, 5) Constructor de la máquina descrita a continuación, 6) Declara que esta máquina, 7) Está conforme a las siguientes directivas y a sus transposiciones en derecho nacional, 8) Para las máquinas anexo IV, 9) Número de certificación, 10) Organismo notificado, 15) normas armonizadas utilizadas, 16) Otras normas o especificaciones técnicas utilizadas, 17) Hecho en, 18) Fecha, 19) Nombre del signatario, 20) Función, 21) Firma.
- et :** 1) EÜ vastavusdeklaratsioon (algupärane), 2) Äriühing, 3) Aadress, 4) Tehniline dokumentatsioon, 5) Seadme tootja, 6) Kinnitab, et see toode, 7) On vastavuses järgmiste direktiivide ja nende riigisisese õigusse ülevõtmiseks vastavõetud õigusaktidega, 8) IV lisas loetletud seadmete puhul, 9) Tunnistuse number, 10) Sertifitseerimisasutus, 15) kasutatud üllustatud standardite, 16) Muud standardites või spetsifikatsioonides kasutati, 17) Väljaandmise koht, 18) Väljaandmise aeg, 19) Allkirjastaja nimi, 20) Amet, 21) Allkiri.
- fi :** 1) EY-vaatimustenmukaisuusvakuutus (alkuperäiset), 2) Yritys, 3) Osoite, 4) teknisen eritelmän, 5) Jäljessä kuvatun koneen valmistaja, 6) Vakuuttaa, että tämä kone, 7) Täyttää seuraavien direktiivien sekä niitä vastaavien kansallisten säännösten vaatimukset, 8) Liitteen IV koneiden osalta, 9) Todistuksen numero, 10) Ilmoitettu laitos, 15) yhdenmukaistettuja standardeja käytetään, 16) muita standardeja tai eritelmät, 17) Paikka, 18) Aika, 19) Allekirjoittajan nimi, 20) Toimi, 21) Allekirjoitus.
- ga :** 1) « EC » dearbhú comhréachta (bunaidh), 2) An comhlacht, 3) Seoladh, 4) comhad teicniúil, 5) Déantóir an innill a thuairiscítear thíos, 6) Dearbháionn sé go bhfuil an inneall, 7) Go gclóíonn sé le na treoracha seo a leanas agus a trasúilí isteach i ndlí náisiúnta, 8) Le haghaidh innill an aguisín IV, 9) Uimhir teastais, 10) Comhlacht a chuireadh i bhfios, 15) caihghdeáin comhchuíbhithe a úsáidtear, 16) caihghdeáin eile nó sonraíochtaí teicniúla a úsáidtear, 17) Déanta ag, 18) Dáta, 19) Ainm an tsínitheora, 20) Feidhm, 21) Síniú.
- hu :** 1) CE megfelelősségi nyilatkozat (eredeti), 2) A vállalat, 3) Cím, 4) műszaki dokumentáció, 5) Az alábbi gép gyártója, 6) Kijelenti, hogy a gép, 7) Megfelel az alábbi irányelveknek valamint azok honosított előírásainak, 8) A IV. melléklet gépeihez, 9) Bizonylati szám, 10) Értesített szervezet, 15) felhasznált harmonizált szabványok, 16) egyéb felhasznált műszaki szabványok és előírások hivatkozásai, 17) Kelt (hely), 18) Dátum, 19) Aláírás neve, 20) Funkció, 21) Aláírás.
- is :** 1) (Samræmisvottorð ESB (upprunalega), 2) Fyrirtækið, 3) Aðsetur, 4) Tæknilegar skrá, 5) Smiður tækisins sem lýst er hér á eftir, 6) Staðfestir að tækið, 7) Samræmist eftirfarandi stöðlum og staðfarlu þeirra með hliðsjón af þjóðarrétti, 8) Fyrir tækin í aukakafli IV, 9) Staðfestingarnúmer, 10) Tilkynt til, 15) samhæfða staða sem notaðir, 16) önnur staðlar eða forskriftir notað, 17) Staður, 18) Dagsetning, 19) Nafn undirritaðs, 20) Staða, 21) Undirskrift.
- it :** 1) Dichiarazione CE di conformità (originale), 2) La società, 3) Indirizzo, 4) fascicolo tecnico, 5) Costruttore della macchina descritta di seguito, 6) Dichiaro che questa macchina, 7) È conforme alle direttive seguenti e alle relative trasposizioni nel diritto nazionale, 8) Per le macchine Allegato IV, 9) Numero di Attestazione, 10) Organismo notificato, 15) norme armonizzate applicate, 16) altre norme e specifiche tecniche applicate, 17) Stabilità a, 18) Data, 19) Nome del firmatario, 20) Funzione, 21) Firma.
- lt :** 1) CE atitikties deklaracija (originalas), 2) Bendrovė, 3) Adresas, 4) Techninė byla, 5) Žemiau nurodytas įrenginio gamintojas, 6) Pareiškia, kad šis įrenginys, 7) Atitinka toliau nurodytas direktyvas ir į nacionalinius teisės aktus perkeltas ju nuostatas, 8) IV priedas dėl mašinų, 9) Sertifikato Nr., 10) Paskelbtųjų įstaiga, 15) suderintus standartus naudojamus, 16) Kiti standartai ir techninės specifikacijos, 17) Pasirašyta, 18) Data, 19) Pasirašiusio asmens vardas ir pavardė, 20) Pareigos, 21) Parašas.
- lv :** 1) EK atbilstības deklarācija (oriģināls), 2) Uzņēmums, 3) Adrese, 4) tehniskās lietas, 5) Tālāk aprakstītās iekārtas ražotājs, 6) Apliecinā, ka šī iekārta, 7) Ir atbilstoša tālāk norādītajām direktīvām un to transpozīcijai nacionālajā likumdošanā, 8) Iekārtām IV pielikumā, 9) Apliecinābas numurs, 10) Reģistrētā organizācija, 15) lietotajiem saskaņotajiem standartiem, 16) lietotajiem tehniskajiem standartiem un specifikācijām, 17) Sastādīts, 18) Datums, 19) Parakstītāja vārds, 20) Amats, 21) Paraksts.
- mt :** 1) Dikjarazzjoni ta' Konformità KE (originali), 2) Il-kumpanija, 3) Indirizz, 4) fajl tekniku, 5) Manifattrici tal-magna deskritta hawn isfel, 6) Tiddikjara li din il-magna, 7) Hija konformi hija konformi mad-Direttivi segwenti u l-Igijiet li jimplimentawhom fil-ligi nazjonal, 8) Għall-magni fl-Anness IV, 9) Numru taċ-certifikat, 10) Entità notifikata, 15) l-istandards armonizzati użati, 16) standards tekniċi u specifikazzjonijiet oħra użati, 17) Magħmul f, 18) Data, 19) Isem il-firmatarju, 20) Kariga, 21) Firma.
- nl :** 1) EG-verklaring van overeenstemming (oorspronkelijke), 2) Het bedrijf, 3) Adres, 4) technisch dossier, 5) Constructeur van de hierna genoemde machine, 6) Verklaart dat deze machine, 7) In overeenstemming is met de volgende richtlijnen en hun omzettingen in het nationale recht, 8) Voor machines van bijlage IV, 9) Goedkeuringsnummer, 10) Aangezegde instelling, 15) gehanteerde geharmoniseerde normen, 16) andere gehanteerde technische normen en specificaties, 17) Opgemaakt te, 18) Datum, 19) Naam van ondergetekende, 20) Functie, 21) Handtekening.
- no :** 1) CE-samsvarserklæring (original), 2) Selskapet, 3) Adresse, 4) tekniske arkiv, 5) Fabrikant av følgende maskin, 6) Erklærer at denne maskinen, 7) Oppfyller kravene i følgende direktiver, med nasjonale gjennomføringsbestemmelser, 8) For maskinene i tillegg IV, 9) Attestnummer, 10) Notifisert organ, 15) harmoniserte standarder som brukes, 16) Andre standarder og spesifikasjoner brukt, 17) Utstedt i, 18) Dato, 19) Underskriverens navn, 20) Stilling, 21) Underskrift.
- pl :** 1) Deklaracja zgodności CE (oryginalne), 2) Spółka, 3) Adres, 4) dokumentacji technicznej, 5) Wykonawca maszyny opisanej poniżej, 6) Oświadcza, że ta maszyna, 7) Jest zgodna z następującymi dyrektywami i odpowiadającymi przepisami prawa krajowego, 8) Dla maszyn załącznik IV, 9) Numer certyfikatu, 10) Jednostka certyfikująca, 15) zastosowanych norm zharmonizowanych, 16) innych zastosowanych norm technicznych i specyfikacji, 17) Sporządzono w, 18) Data, 19) Nazwisko podpisującego, 20) Stanowisko, 21) Podpis.
- pt :** 1) Declaração de conformidade CE (original), 2) A empresa, 3) Morada, 4) processo técnico, 5) Fabricante da máquina descrita abaixo, 6) Declara que esta máquina, 7) Está em conformidade às diretivas seguintes e às suas transposições para o direito nacional, 8) Para as máquinas no anexo IV, 9) Número de certificado, 10) Entidade notificada, 15) normas harmonizadas utilizadas, 16) outras normas e especificações técnicas utilizadas, 17) Elaborado em, 18) Data, 19) Nome do signatário, 20) Cargo, 21) Assinatura.
- ro :** 1) Declarație de conformitate CE (originală), 2) Societatea, 3) Adresa, 4) cartii tehnice, 5) Constructor al mașinii descrise mai jos, 6) Declară că prezenta mașină, 7) Este conformă cu directivele următoare și cu transpunerea lor în dreptul național, 8) Pentru mașinile din anexa IV, 9) Număr de atestare, 10) Organism notificat, 15) standardele armonizate utilizate, 16) alte standarde și specificații tehnice utilizate, 17) Întocmit la, 18) Data, 19) Numele persoanei care semnează, 20) Funcția, 21) Semnătura.
- sk :** 1) ES vyhlásenie o zhode (pôvodný), 2) Názov spoločnosti, 3) Adresa, 4) technickej dokumentácie, 5) Výrobca nižšie opísaného stroja, 6) Vyhlasuje, že tento stroj, 7) Je v súlade s nasledujúcimi smernicami a smernicami transponovanými do vnútroštátneho práva, 8) Pre stroje v prílohe IV, 9) Číslo certifikátu, 10) Notifikačný orgán, 15) použité harmonizované normy, 16) použité iné technické normy a predpisy, 17) Miesto vydania, 18) Dátum vydania, 19) Meno podpisujúceho, 20) Funkcia, 21) Podpis.
- sl :** 1) ES Izjava o ustreznosti (izvirna), 2) Družba, 3) Naslov, 4) tehnične dokumentacije, 5) Proizvajalac tukaj opisanega stroja, 6) Izjavlja, da je ta stroj, 7) Ustreza naslednjim direktivam in njihovi transpoziciji v državno pravo, 8) Za stroje priloga IV, 9) Številka potrdila, 10) Obvestilo organu, 15) uporabljene harmonizirane standarde, 16) druge uporabljene tehnične standarde in zahteve, 17) V, 18) Datum, 19) Ime podpisnika, 20) Funkcija, 21) Podpis.
- sv :** 1) CE-försäkran om överensstämmelse (original), 2) Företaget, 3) Adress, 4) tekniska dokumentationen, 5) Konstruktör av nedan beskrivna maskin, 6) Försäkrar att denna maskin, 7) Överensstämmer med nedanstående direktiv och införlivandet av dem i nationell rätt, 8) För maskinerna i bilaga IV, 9) Nummer för godkännande, 10) Organism som underrättats, 15) Harmoniserade standarder som använts, 16) andra tekniska standarder och specifikationer som använts, 17) Upprättat i, 18) Datum, 19) Namn på den som undertecknat, 20) Befattning, 21) Namnteckning.



«EC» DECLARATION OF CONFORMITY - 180 ATJ 2 E3 ET 180 ATJ 2 E3 RC

• UP TO THE LIFTING PLATFORM No. 951 457 EXCEPT LIFTING PLATFORM No. 950 552

- 1) **DÉCLARATION «CE» DE CONFORMITÉ (originale)**
« EC » DECLARATION OF CONFORMITY (original)
- 2) La société, *The company* : MANITOU BF
- 3) Adresse, *Address* : 430, rue de l'Aubinière - BP 10249 - 44158 - ANCENIS CEDEX - FRANCE
- 4) Dossier technique, *Technical file* : MANITOU BF - 430, rue de l'Aubinière
BP 10249 - 44158 - ANCENIS CEDEX - FRANCE
- 5) Constructeur de la machine décrite ci-après, *Manufacturer of the machine described below* :
180 ATJ 2 E3 et 180 ATJ 2 E3 RC
- 6) Déclare que cette machine, *Declares that this machine* :
- 7) Est conforme aux directives suivantes et à leurs transpositions en droit national, *Complies with the following directives and their transpositions into national law* :
2006/42/CE
8) Pour les machines annexe IV , *For annex IV machines* :
9) Numéro d'attestation, *Certificate number* : 0526 5131 760 05 13 4968
10) Organisme notifié, *Notified body* : CETIM NB N° 0526
52 avenue Felix Louat - BP 80067
60304 SENLIS CEDEX FRANCE
2000/14/CE + 2005/88/CE
11) Numéro d'attestation, *Certificate number* :
10) Organisme notifié, *Notified body* :
12) Niveau de puissance acoustique, *Sound power level* :
13) Mesuré, *Measured* : 103,5 dB (A)
14) Garanti, *Guaranteed* : 104 dB (A)
2004/108/CE
11) Numéro d'attestation, *Certificate number* :
10) Organisme notifié, *Notified body* :
- 15) Normes harmonisées utilisées, *Harmonised standards used* : EN12895
- 16) Normes ou dispositions techniques utilisées, *Standards or technical provisions used* :
- 17) Fait à, *Done at* : Ancenis 18) Date, *Date* : 30/05/2013
- 19) Nom du signataire, *Name of signatory* : Dominique BAMAS
- 20) Fonction, *Function* : Directeur général
- 21) Signature, *Signature* :



- bg :** 1) удостоверение за « CE » съответствие (оригинална), 2) Фирмата, 3) Адрес, 4) Техническо досие, 5) Фабрикант на описаната по-долу машина, 6) Обявява, че тази машина, 7) Отговаря на следните директиви и на тяхното съответствие национално право, 8) За машините към допълнение IV, 9) Номер на удостоверението, 10) Наименувана фирма, 15) хармонизирани стандарти използвани, 16) стандарти или технически правила, използвани, 17) Изработено в, 18) Дата, 19) Име на разписалия се, 20) Функция, 21) Функция.
- cs :** 1) **ES prohlášení o shodě (původní)**, 2) Název společnosti, 3) Adresa, 4) Technická dokumentace, 5) Výrobce níže uvedeného stroje, 6) Prohlašuje, že tento stroj, 7) Je v souladu s následujícími směrnici a s směrnici transponovanými do vnitrostátního práva, 8) Pro stroje v příloze IV, 9) Číslo certifikátu, 10) Notifikační orgán, 15) harmonizované normy použity, 16) Norem a technických pravidel používaných, 17) Místo vydání, 18) Datum vydání, 19) Jméno podepsaného, 20) Funkce, 21) Podpis.
- da :** 1) **EF Overensstemmelseserklæring (original)**, 2) Firmaet, 3) Adresse, 4) tekniske dossier, 5) Konstruktør af nedenfor beskrevne maskine, 6) Erklærer, at denne maskine, 7) Overholder nedennævnte direktiver og disses gennemførelse til national ret, 8) For maskiner under bilag IV, 9) Certifikat nummer, 10) Bemyndigede organ, 15) harmoniserede standarder, der anvendes, 16) standarder eller tekniske regler, 17) Udfærdiget i, 18) Dato, 19) Underskrivers navn, 20) Funktion, 21) Underskrift.
- de :** 1) **EG-Konformitätserklärung (original)**, 2) Die Firma, 3) Adresse, 4) Technischen Unterlagen, 5) Hersteller der nachfolgend beschriebenen Maschine, 6) Erklärt, dass diese Maschine, 7) den folgenden Richtlinien und deren Umsetzung in die nationale Gesetzgebung entspricht, 8) Für die Maschinen laut Anhang IV, 9) Bescheinigungsnummer, 10) Benannte Stelle, 15) angewandten harmonisierten Normen, 16) angewandten sonstigen technischen Normen und Spezifikationen, 17) Ausgestellt in, 18) Datum, 19) Name des Unterzeichners, 20) Funktion, 21) Unterschrift.
- el :** 1) **Δήλωση συμμόρφωσης CE (πρωτότυπο)**, 2) Η εταιρεία, 3) Διεύθυνση, 4) τεχνικό φάκελο, 5) Κατασκευάστρια του εξής περιγραφόμενου μηχανήματος, 6) Δηλώνει ότι αυτό το μηχάνημα, 7) Είναι σύμφωνο με τις εξής οδηγίες και τις προσαρμογές τους στο εθνικό δίκαιο, 8) Για τα μηχανήματα παραρτήματος IV, 9) Αριθμός δήλωσης, 10) Κοινοποιημένος φορέας, 15) εναρμονισμένα πρότυπα που χρησιμοποιούνται, 16) Πρότυπα ή τεχνικούς κανόνες που χρησιμοποιούνται, 16) Είναι σύμφωνο με τα εξής πρότυπα και τεχνικές διατάξεις, 17) Έν, 18) Ημερομηνία, 19) Όνομα του υπογράφοντος, 20) Θέση, 21) Υπογραφή.
- es :** 1) **Declaración DE de conformidad (original)**, 2) La sociedad, 3) Dirección, 4) expediente técnico, 5) Constructor de la máquina descrita a continuación, 6) Declara que esta máquina, 7) Está conforme a las siguientes directivas y a sus transposiciones en derecho nacional, 8) Para las máquinas anexo IV, 9) Número de certificación, 10) Organismo notificado, 15) normas armonizadas utilizadas, 16) Otras normas o especificaciones técnicas utilizadas, 17) Hecho en, 18) Fecha, 19) Nombre del signatario, 20) Función, 21) Firma.
- et :** 1) **EÜ vastavusdeklaratsioon (algupärane)**, 2) Äriühing, 3) Aadress, 4) Tehniline dokumentatsioon, 5) Seadme tootja, 6) Kinnitab, et see toode, 7) On vastavuses järgmiste direktiivide ja nende riigisisese õigussesse ülevõtmiseks vastuvõetud õigusaktidega, 8) IV lisas loetletud seadmete puhul, 9) Tunnistuse number, 10) Sertifitseerimisasutus, 15) kasutatud üllustatud standardite, 16) Muud standardites või spetsifikatsioonides kasutatakse, 17) Väljaandmise koht, 18) Väljaandmise aeg, 19) Allkirjastaja nimi, 20) Amet, 21) Allkiri.
- fi :** 1) **EY-vaatimustenmukaisuusvakuutus (alkuperäiset)**, 2) Yritys, 3) Osoite, 4) teknisen eritelmän, 5) Jäljessä kuvatun koneen valmistaja, 6) Vakuuttaa, että tämä kone, 7) Täyttää seuraavien direktiivien sekä niitä vastaavien kansallisten säännösten vaatimukset, 8) Liitteen IV koneiden osalta, 9) Todistuksen numero, 10) Ilmoitettu laitos, 15) yhdenmukaistettuja standardeja käytetään, 16) muita standardeja tai eritelmät, 17) Paikka, 18) Aika, 19) Allekirjoittajan nimi, 20) Toimi, 21) Allekirjoitus.
- ga :** 1) « **EC » dearbhú comhréachta (bunaidh)**, 2) An comhlacht, 3) Seoladh, 4) comhad teicniúil, 5) Déantóir an innill a thuairiscítear thíos, 6) Dearbháionn sé go bhfuil an t-inneall, 7) Go gclóíonn sé le na teorachas seo a leanas agus a trasúimh isteach i ndlí náisiúnta, 8) Le haghaidh innill an aguisín IV, 9) Uimhir teastais, 10) Comhlacht a chuireadh i bhfios, 15) caighdeáin comhchuíbhithe a úsáidtear, 16) caighdeáin eile nó sonraíochtaí teicniúla a úsáidtear, 17) Déanta ag, 18) Dáta, 19) Ainm an tsínitheora, 20) Feidhm, 21) Síniú.
- hu :** 1) **CE megfelelősigi nyilatkozat (eredeti)**, 2) A vállalat, 3) Cím, 4) műszaki dokumentáció, 5) Az alábbi gép gyártója, 6) Kijelenti, hogy a gép, 7) Megfelel az alábbi irányelveknek valamint azok honosított előírásainak, 8) A IV. melléklet gépeihez, 9) Bizonylati szám, 10) Értesített szervezet, 15) felhasznált harmonizált szabványok, 16) egyéb felhasznált műszaki szabványok és előírások hivatkozásai, 17) Kelt (hely), 18) Dátum, 19) Aláíró neve, 20) Funkció, 21) Aláírás.
- is :** 1) **(Samræmisvottorð ESB (upprunalega)**, 2) Fyrirtækið, 3) Aðsetur, 4) Tæknilegar skrá, 5) Smíður tækisins sem lýst er hér á eftir, 6) Staðfestir að tækið, 7) Samræmist eftirfarandi stöðlum og staðfarlu þeirra með hljóðin af þjóðarrétti, 8) Fyrir tækin í aukakafli IV, 9) Staðfestingarnúmer, 10) Tilkynnt til, 15) samhæfða staða sem notaðir, 16) önnur staðlar eða forskrifir notað, 17) Staður, 18) Dagsetning, 19) Nafn undirritaðs, 20) Staða, 21) Undirskrift.
- it :** 1) **Dichiarazione CE di conformità (originale)**, 2) La società, 3) Indirizzo, 4) fascicolo tecnico, 5) Costruttore della macchina descritta di seguito, 6) Dichiaro che questa macchina, 7) È conforme alle direttive seguenti e alle relative trasposizioni nel diritto nazionale, 8) Per le macchine Allegato IV, 9) Numero di Attestazione, 10) Organismo notificato, 15) norme armonizzate applicate, 16) altre norme e specifiche tecniche applicate, 17) Stabilità a, 18) Data, 19) Nome del firmatario, 20) Funzione, 21) Firma.
- lt :** 1) **CE atitikties deklaracija (originalas)**, 2) Bendrovė, 3) Adresas, 4) Techninė byla, 5) Žemiau nurodytas įrenginio gamintojas, 6) Pareiškia, kad šis įrenginys, 7) Atitinka toliau nurodytas direktyvas ir į nacionalinius teisės aktus perkeltas jų nuostatas, 8) IV priedas dėl mašinų, 9) Sertifikato Nr., 10) Paskelbtųjų įstaiga, 15) suderintus standartus naudojamus, 16) Kiti standartai ir techninės specifikacijos, 17) Pasirašyta, 18) Data, 19) Pasirašiusio asmens vardas ir pavardė, 20) Pareigos, 21) Parašas.
- lv :** 1) **EK atbilstības deklarācija (oriģināls)**, 2) Uzņēmums, 3) Adrese, 4) tehniskās lietas, 5) Tālāk aprakstītās iekārtas ražotājs, 6) Apliecinā, ka šī iekārta, 7) Ir atbilstoša tālāk norādītajām direktīvām un to transpozīcijai nacionālajā likumdošanā, 8) Iekārtām IV pielikumā, 9) Apliecinābas numurs, 10) Reģistrētā organizācija, 15) lietotajiem saskaņotajiem standartiem, 16) lietotajiem tehniskajiem standartiem un specifikācijām, 17) Sastādīts, 18) Datums, 19) Parakstītāja vārds, 20) Amats, 21) Paraksts.
- mt :** 1) **Dikjarazzjoni ta' Konformità KE (originali)**, 2) Il-kumpanija, 3) Indirizz, 4) fajl tekniku, 5) Manifattrici tal-magna deskritta hawn isfel, 6) Tiddikjara li din il-magna, 7) Hija konformi hija konformi mad-Direttivi segwenti u l-Igijiet li jimplimentawhom fil-ligi nazjonal, 8) Għall-magni fl-Anness IV, 9) Numru taċ-certifikat, 10) Entità notifikata, 15) l-istandards armonizzati użati, 16) standards tekniċi u specifikazzjonijiet oħra użati, 17) Magħmul f, 18) Data, 19) Isem il-firmatarju, 20) Kariga, 21) Firma.
- nl :** 1) **EG-verklaring van overeenstemming (oorspronkelijke)**, 2) Het bedrijf, 3) Adres, 4) technisch dossier, 5) Constructeur van de hierna genoemde machine, 6) Verklaart dat deze machine, 7) In overeenstemming is met de volgende richtlijnen en hun omzettingen in het nationale recht, 8) Voor machines van bijlage IV, 9) Goedkeuringsnummer, 10) Aangezegde instelling, 15) gehanteerde geharmoniseerde normen, 16) andere gehanteerde technische normen en specificaties, 17) Opgemaakt te, 18) Datum, 19) Naam van ondergetekende, 20) Functie, 21) Handtekening.
- no :** 1) **CE-samsvarserklæring (original)**, 2) Selskapet, 3) Adresse, 4) tekniske arkiv, 5) Fabrikant av følgende maskin, 6) Erklærer at denne maskinen, 7) Oppfyller kravene i følgende direktiver, med nasjonale gjennomføringsbestemmelser, 8) For maskinene i tillegg IV, 9) Attestnummer, 10) Notifisert organ, 15) harmoniserte standarder som brukes, 16) Andre standarder og spesifikasjoner brukt, 17) Utstedt i, 18) Dato, 19) Underskriverens navn, 20) Stilling, 21) Underskrift.
- pl :** 1) **Deklaracja zgodności CE (oryginalne)**, 2) Spółka, 3) Adres, 4) dokumentacji technicznej, 5) Wykonawca maszyny opisanej poniżej, 6) Oświadcza, że ta maszyna, 7) Jest zgodna z następującymi dyrektywami i odpowiadającymi przepisami prawa krajowego, 8) Dla maszyn załącznik IV, 9) Numer certyfikatu, 10) Jednostka certyfikująca, 15) zastosowanych norm zharmonizowanych, 16) innych zastosowanych norm technicznych i specyfikacji, 17) Sporządzono w, 18) Data, 19) Nazwisko podpisującego, 20) Stanowisko, 21) Podpis.
- pt :** 1) **Declaração de conformidade CE (original)**, 2) A empresa, 3) Morada, 4) processo técnico, 5) Fabricante da máquina descrita abaixo, 6) Declara que esta máquina, 7) Está em conformidade às diretivas seguintes e às suas transposições para o direito nacional, 8) Para as máquinas no anexo IV, 9) Número de certificado, 10) Entidade notificada, 15) normas harmonizadas utilizadas, 16) outras normas e especificações técnicas utilizadas, 17) Elaborado em, 18) Data, 19) Nome do signatário, 20) Cargo, 21) Assinatura.
- ro :** 1) **Declarație de conformitate CE (originală)**, 2) Societatea, 3) Adresa, 4) cârtii tehnice, 5) Constructor al mașinii descrise mai jos, 6) Declară că prezenta mașină, 7) Este conformă cu directivele următoare și cu transpunerea lor în dreptul național, 8) Pentru mașinile din anexa IV, 9) Număr de atestare, 10) Organism notificat, 15) standardele armonizate utilizate, 16) alte standarde și specificații tehnice utilizate, 17) Întocmit la, 18) Data, 19) Numele persoanei care semnează, 20) Funcția, 21) Semnătura.
- sk :** 1) **ES vyhlásenie o zhode (pôvodný)**, 2) Názov spoločnosti, 3) Adresa, 4) technickej dokumentácie, 5) Výrobca nižšie opísaného stroja, 6) Vyhlasuje, že tento stroj, 7) Je v súlade s nasledujúcimi smernicami a smernicami transponovanými do vnútroštátneho práva, 8) Pre stroje v prílohe IV, 9) Číslo certifikátu, 10) Notifikačný orgán, 15) použité harmonizované normy, 16) použité iné technické normy a predpisy, 17) Miesto vydania, 18) Dátum vydania, 19) Meno podpisujúceho, 20) Funkcia, 21) Podpis.
- sl :** 1) **ES Izjava o ustreznosti (izvirna)**, 2) Družba, 3) Naslov, 4) tehnične dokumentacije, 5) Proizvajalac tukaj opisanega stroja, 6) Izjavlja, da je ta stroj, 7) Ustreza naslednjim direktivam in njihovi transpoziciji v državno pravo, 8) Za stroje priloga IV, 9) Številka potrdila, 10) Obvestilo organu, 15) uporabljene harmonizirane standarde, 16) druge uporabljene tehnične standarde in zahteve, 17) V, 18) Datum, 19) Ime podpisnika, 20) Funkcija, 21) Podpis.
- sv :** 1) **CE-försäkran om överensstämmelse (original)**, 2) Företaget, 3) Adress, 4) tekniska dokumentationen, 5) Konstruktör av nedan beskrivna maskin, 6) Försäkrar att denna maskin, 7) Överensstämmer med nedanstående direktiv och införlivandet av dem i nationell rätt, 8) För maskinerna i bilaga IV, 9) Nummer för godkännande, 10) Organism som underrättats, 15) Harmoniserade standarder som använts, 16) andra tekniska standarder och specifikationer som använts, 17) Upprättat i, 18) Datum, 19) Namn på den som undertecknat, 20) Befattning, 21) Namntecknin.



«EC» DECLARATION OF CONFORMITY - 180 ATJ 2 E3 ET 180 ATJ 2 E3 RC

• FROM THE LIFTING PLATFORM No. 951 458 AND LIFTING PLATFORM No. 950 552

1) **DÉCLARATION «CE» DE CONFORMITÉ (originale)**
« EC » DECLARATION OF CONFORMITY (original)

2) La société, **The company** : MANITOU BF

3) Adresse, **Address** : 430, rue de l'Aubinière - BP 10249 - 44158 - ANCENIS CEDEX - FRANCE

4) Dossier technique, **Technical file** : MANITOU BF - 430, rue de l'Aubinière
BP 10249 - 44158 - ANCENIS CEDEX - FRANCE

5) Constructeur de la machine décrite ci-après, **Manufacturer of the machine described below** :

180 ATJ 2 E3

6) Déclare que cette machine, **Declares that this machine** :

7) Est conforme aux directives suivantes et à leurs transpositions en droit national, **Complies with the following directives and their transpositions into national law** :

2006/42/CE

8) Pour les machines annexe IV , **For annex IV machines** :

9) Numéro d'attestation, **Certificate number** : 0062 5131 760 04 15 0312

10) Organisme notifié, **Notified body** : VERITAS

61/71 Boulevard du Château

92 571 NEUILLY SUR SEINE FRANCE

2000/14/CE + 2005/88/CE

11) Numéro d'attestation, **Certificate number** :

10) Organisme notifié, **Notified body** :

12) Niveau de puissance acoustique, **Sound power level** :

13) Mesuré, **Measured** : 103,5 dB (A)

14) Garanti, **Guaranteed** : 104 dB (A)

2004/108/CE

11) Numéro d'attestation, **Certificate number** :

10) Organisme notifié, **Notified body** :

15) Normes harmonisées utilisées, **Harmonised standards used** : EN12895

16) Normes ou dispositions techniques utilisées, **Standards or technical provisions used** :

17) Fait à, **Done at** : Ancenis

18) Date, **Date** :

19) Nom du signataire, **Name of signatory** : Fernand MIRA

20) Fonction, **Function** : Président division MHA

21) Signature, **Signature** :



- bg :** 1) удостоверение за « CE » съответствие (оригинална), 2) Фирмата, 3) Адрес, 4) Техническо досие, 5) Фабрикант на описаната по-долу машина, 6) Обявява, че тази машина, 7) Отговаря на следните директиви и на тяхното съответствие национално право, 8) За машините към допълнение IV, 9) Номер на удостоверението, 10) Наименувана фирма, 15) хармонизирани стандарти използвани, 16) стандарти или технически правила, използвани, 17) Изработено в, 18) Дата, 19) Име на разписалия се, 20) Функция, 21) Функция.
- cs :** 1) ES prohlášení o shodě (původní), 2) Název společnosti, 3) Adresa, 4) Technická dokumentace, 5) Výrobce níže uvedeného stroje, 6) Prohlašuje, že tento stroj, 7) Je v souladu s následujícími směrnicemi a směrnici transponovanými do vnitrostátního práva, 8) Pro stroje v příloze IV, 9) Číslo certifikátu, 10) Notifikační orgán, 15) harmonizované normy použity, 16) Norem a technických pravidel používaných, 17) Místo vydání, 18) Datum vydání, 19) Jméno podepsaného, 20) Funkce, 21) Podpis.
- da :** 1) EF Overensstemmelseerklæring (original), 2) Firmaet, 3) Adresse, 4) tekniske dossier, 5) Konstruktør af nedenfor beskrevne maskine, 6) Erklærer, at denne maskine, 7) Overholder nedennævnte direktiver og disses gennemførelse til national ret, 8) For maskiner under bilag IV, 9) Certifikat nummer, 10) Bemyndigede organ, 15) harmoniserede standarder, der anvendes, 16) standarder eller tekniske regler, 17) Udfærdiget i, 18) Dato, 19) Underskrivers navn, 20) Funktion, 21) Underskrift.
- de :** 1) EG-Konformitätserklärung (original), 2) Die Firma, 3) Adresse, 4) Technischen Unterlagen, 5) Hersteller der nachfolgend beschriebenen Maschine, 6) Erklärt, dass diese Maschine, 7) den folgenden Richtlinien und deren Umsetzung in die nationale Gesetzgebung entspricht, 8) Für die Maschinen laut Anhang IV, 9) Bescheinigungsnummer, 10) Benannte Stelle, 15) angewandten harmonisierten Normen, 16) angewandten sonstigen technischen Normen und Spezifikationen, 17) Ausgestellt in, 18) Datum, 19) Name des Unterzeichners, 20) Funktion, 21) Unterschrift.
- el :** 1) Δήλωση συμμόρφωσης CE (πρωτότυπο), 2) Η εταιρεία, 3) Διεύθυνση, 4) τεχνικό φάκελο, 5) Κατασκευάστρια του εξής περιγραφόμενου μηχανήματος, 6) Δηλώνει ότι αυτό το μηχάνημα, 7) Είναι σύμφωνο με τις εξής οδηγίες και τις προσαρμογές τους στο εθνικό δίκαιο, 8) Για τα μηχανήματα παραρτήματος IV, 9) Αριθμός δήλωσης, 10) Κοινοποιημένος φορέας, 15) εναρμονισμένα πρότυπα που χρησιμοποιούνται, 16) Πρότυπα ή τεχνικούς κανόνες που χρησιμοποιούνται, 16) Είναι σύμφωνο με τα εξής πρότυπα και τεχνικές διατάξεις, 17) Εν, 18) Ημερομηνία, 19) Όνομα του υπογράφοντος, 20) Θέση, 21) Υπογραφή.
- es :** 1) Declaración DE de conformidad (original), 2) La sociedad, 3) Dirección, 4) expediente técnico, 5) Constructor de la máquina descrita a continuación, 6) Declara que esta máquina, 7) Está conforme a las siguientes directivas y a sus transposiciones en derecho nacional, 8) Para las máquinas anexo IV, 9) Número de certificación, 10) Organismo notificado, 15) normas armonizadas utilizadas, 16) Otras normas o especificaciones técnicas utilizadas, 17) Hecho en, 18) Fecha, 19) Nombre del signatario, 20) Función, 21) Firma.
- et :** 1) EÜ vastavusdeklaratsioon (algupärane), 2) Äriühing, 3) Aadress, 4) Tehniline dokumentatsioon, 5) Seadme tootja, 6) Kinnitab, et see toode, 7) On vastavuses järgmiste direktiivide ja nende riigisisese õigussisse ülevõtmiseks vastavõetud õigusaktidega, 8) IV lisas loetletud seadmete puhul, 9) Tunnistuse number, 10) Sertifitseerimisasutus, 15) kasutatud üllustatud standardite, 16) Muud standardites või spetsifikatsioonides kasutatakse, 17) Väljaandmise koht, 18) Väljaandmise aeg, 19) Allkirjastaja nimi, 20) Amet, 21) Allkiri.
- fi :** 1) EY-vaatimustenmukaisuusvakuutus (alkuperäiset), 2) Yritys, 3) Osoite, 4) teknisen eritelmän, 5) Jäljessä kuvatun koneen valmistaja, 6) Vakuuttaa, että tämä kone, 7) Täyttää seuraavien direktiivien sekä niitä vastaavien kansallisten säännösten vaatimukset, 8) Liitteen IV koneiden osalta, 9) Todistuksen numero, 10) Ilmoitettu laitos, 15) yhdenmukaistettuja standardeja käytetään, 16) muita standardeja tai eritelmät, 17) Paikka, 18) Aika, 19) Allekirjoittajan nimi, 20) Toimi, 21) Allekirjoitus.
- ga :** 1) « EC » dearbhú comhréachta (bunaidh), 2) An comhlacht, 3) Seoladh, 4) comhad teicniúil, 5) Déantóir an innill a thuairiscítear thíos, 6) Dearbháionn sé go bhfuil an inneall, 7) Go gclóíonn sé le na treoracha seo a leanas agus a trasúilhm isteach i ndlí náisiúnta, 8) Le haghaidh innill an aguisín IV, 9) Uimhir teastais, 10) Comhlacht a chuireadh i bhfios, 15) caighdeáin comhchuibhithe a úsáidtear, 16) caighdeáin eile nó sonraíochtaí teicniúla a úsáidtear, 17) Déanta ag, 18) Dáta, 19) Ainm an tsínitheora, 20) Feidhm, 21) Síniú.
- hu :** 1) CE megfelelősigi nyilatkozat (eredeti), 2) A vállalat, 3) Cím, 4) műszaki dokumentáció, 5) Az alábbi gép gyártója, 6) Kijelenti, hogy a gép, 7) Megfelel az alábbi irányelveknek valamint azok honosított előírásainak, 8) A IV. melléklet gépeihez, 9) Bizonylati szám, 10) Értesített szervezet, 15) felhasznált harmonizált szabványok, 16) egyéb felhasznált műszaki szabványok és előírások hivatkozásai, 17) Kelt (hely), 18) Dátum, 19) Aláíró neve, 20) Funkció, 21) Aláírás.
- is :** 1) Samræmisvottorð ESB (upprunalega), 2) Fyrirtækið, 3) Aðsetur, 4) Tæknilegar skrá, 5) Smiður tækisins sem lýst er hér á eftir, 6) Staðfestir að tækið, 7) Samræmist eftirfarandi stöðlum og staðfærslu þeirra með hljóðin af þjóðarrétti, 8) Fyrir tækin í aukakafli IV, 9) Staðfestingarnúmer, 10) Tilkynt til, 15) samhæfða staða sem notaðir, 16) önnur staðlar eða forskrifir notað, 17) Staður, 18) Dagsetning, 19) Nafn undirritaðs, 20) Staða, 21) Undirskrift.
- it :** 1) Dichiarazione CE di conformità (originale), 2) La società, 3) Indirizzo, 4) fascicolo tecnico, 5) Costruttore della macchina descritta di seguito, 6) Dichiaro che questa macchina, 7) È conforme alle direttive seguenti e alle relative trasposizioni nel diritto nazionale, 8) Per le macchine Allegato IV, 9) Numero di Attestazione, 10) Organismo notificato, 15) norme armonizzate applicate, 16) altre norme e specifiche tecniche applicate, 17) Stabilità a, 18) Data, 19) Nome del firmatario, 20) Funzione, 21) Firma.
- lt :** 1) CE atitikties deklaracija (originalas), 2) Bendrovė, 3) Adresas, 4) Techninė byla, 5) Žemiau nurodytas įrenginio gamintojas, 6) Pareiškia, kad šis įrenginys, 7) Atitinka toliau nurodytas direktyvas ir į nacionalinius teisės aktus perkeltas jų nuostatas, 8) IV priedas dėl mašinų, 9) Sertifikato Nr., 10) Paskelbtoji įstaiga, 15) suderintus standartus naudojamus, 16) Kiti standartai ir techninės specifikacijos, 17) Pasirašyta, 18) Data, 19) Pasirašiusio asmens vardas ir pavardė, 20) Pareigos, 21) Parašas.
- lv :** 1) EK atbilstības deklarācija (oriģināls), 2) Uzņēmums, 3) Adrese, 4) tehniskās lietas, 5) Tālāk aprakstītās iekārtas ražotājs, 6) Apliecinā, ka šī iekārta, 7) Ir atbilstoša tālāk norādītajām direktīvām un to transpozīcijai nacionālajā likumdošanā, 8) Iekārtām IV pielikumā, 9) Apliecinābas numurs, 10) Reģistrētā organizācija, 15) lietotajiem saskaņotajiem standartiem, 16) lietotajiem tehniskajiem standartiem un specifikācijām, 17) Sastādīts, 18) Datums, 19) Parakstītāja vārds, 20) Amats, 21) Paraksts.
- mt :** 1) Dikjarazzjoni ta' Konformità KE (originali), 2) Il-kumpanija, 3) Indirizz, 4) fajl tekniku, 5) Manifattrici tal-magna deskritta hawn isfel, 6) Tiddikjara li din il-magna, 7) Hija konformi hija konformi mad-Direttivi segwenti u l-Igijiet li jimplimentawhom fil-ligi nazzjonali, 8) Għall-magni fl-Anness IV, 9) Numru taċ-certifikat, 10) Entità notifikata, 15) l-istandards armonizzati użati, 16) standards tekniċi u specifikazzjonijiet oħra użati, 17) Magħmul f, 18) Data, 19) Isem il-firmatarju, 20) Kariga, 21) Firma.
- nl :** 1) EG-verklaring van overeenstemming (oorspronkelijk), 2) Het bedrijf, 3) Adres, 4) technisch dossier, 5) Constructeur van de hierna genoemde machine, 6) Verklaart dat deze machine, 7) In overeenstemming is met de volgende richtlijnen en hun omzettingen in het nationale recht, 8) Voor machines van bijlage IV, 9) Goedkeuringsnummer, 10) Aangezegde instelling, 15) gehanteerde geharmoniseerde normen, 16) andere gehanteerde technische normen en specificaties, 17) Opgemaakt te, 18) Datum, 19) Naam van ondergetekende, 20) Functie, 21) Handtekening.
- no :** 1) CE-samsvarserklæring (original), 2) Selskapet, 3) Adresse, 4) tekniske arkiv, 5) Fabrikant av følgende maskin, 6) Erklærer at denne maskinen, 7) Oppfyller kravene i følgende direktiver, med nasjonale gjennomføringsbestemmelser, 8) For maskinene i tillegg IV, 9) Attestnummer, 10) Notifisert organ, 15) harmoniserte standarder som brukes, 16) Andre standarder og spesifikasjoner brukt, 17) Utstedt i, 18) Dato, 19) Underskriverens navn, 20) Stilling, 21) Underskrift.
- pl :** 1) Deklaracja zgodności CE (oryginalne), 2) Spółka, 3) Adres, 4) dokumentacji technicznej, 5) Wykonawca maszyny opisanej poniżej, 6) Oświadcza, że ta maszyna, 7) Jest zgodna z następującymi dyrektywami i odpowiadającymi przepisami prawa krajowego, 8) Dla maszyn załącznik IV, 9) Numer certyfikatu, 10) Jednostka certyfikująca, 15) zastosowanych norm zharmonizowanych, 16) innych zastosowanych norm technicznych i specyfikacji, 17) Sporządzono w, 18) Data, 19) Nazwisko podpisującego, 20) Stanowisko, 21) Podpis.
- pt :** 1) Declaração de conformidade CE (original), 2) A empresa, 3) Morada, 4) processo técnico, 5) Fabricante da máquina descrita abaixo, 6) Declara que esta máquina, 7) Está em conformidade às diretivas seguintes e às suas transposições para o direito nacional, 8) Para as máquinas no anexo IV, 9) Número de certificado, 10) Entidade notificada, 15) normas harmonizadas utilizadas, 16) outras normas e especificações técnicas utilizadas, 17) Elaborado em, 18) Data, 19) Nome do signatário, 20) Cargo, 21) Assinatura.
- ro :** 1) Declarație de conformitate CE (originală), 2) Societatea, 3) Adresa, 4) cârții tehnice, 5) Constructor al mașinii descrise mai jos, 6) Declară că prezenta mașină, 7) Este conformă cu directivele următoare și cu transpunerea lor în dreptul național, 8) Pentru mașinile din anexa IV, 9) Număr de atestare, 10) Organism notificat, 15) standardele armonizate utilizate, 16) alte standarde și specificații tehnice utilizate, 17) Întocmit la, 18) Data, 19) Numele persoanei care semnează, 20) Funcția, 21) Semnătura.
- sk :** 1) ES vyhlásenie o zhode (pôvodný), 2) Názov spoločnosti, 3) Adresa, 4) technickej dokumentácie, 5) Výrobca nižšie opísaného stroja, 6) Vyhlasuje, že tento stroj, 7) Je v súlade s nasledujúcimi smernicami a smernicami transponovanými do vnútroštátneho práva, 8) Pre stroje v prílohe IV, 9) Číslo certifikátu, 10) Notifikačný orgán, 15) použité harmonizované normy, 16) použité iné technické normy a predpisy, 17) Miesto vydania, 18) Dátum vydania, 19) Meno podpisujúceho, 20) Funkcia, 21) Podpis.
- sl :** 1) ES Izjava o ustreznosti (izvirna), 2) Družba, 3) Naslov, 4) tehnične dokumentacije, 5) Proizvajalac tukaj opisanega stroja, 6) Izjavlja, da je ta stroj, 7) Ustreza naslednjim direktivam in njihovi transpoziciji v državno pravo, 8) Za stroje priloga IV, 9) Številka potrdila, 10) Obvestilo organu, 15) uporabljene harmonizirane standarde, 16) druge uporabljene tehnične standarde in zahteve, 17) V, 18) Datum, 19) Ime podpisnika, 20) Funkcija, 21) Podpis.
- sv :** 1) CE-försäkran om överensstämmelse (original), 2) Företaget, 3) Adress, 4) tekniska dokumentationen, 5) Konstruktör av nedan beskrivna maskin, 6) Försäkrar att denna maskin, 7) Överensstämmer med nedanstående direktiv och införlivandet av dem i nationell rätt, 8) För maskinerna i bilaga IV, 9) Nummer för godkännande, 10) Organism som underrättats, 15) Harmoniserade standarder som använts, 16) andra tekniska standarder och specifikationer som använts, 17) Upprättat i, 18) Datum, 19) Namn på den som undertecknat, 20) Befattning, 21) Namntecknin.



LIFTING PLATFORM ID

LIFTING PLATFORM'S MANUFACTURER'S PLATE (FIG.A)

- Type :
- Serial No.:
- Year of manufacture:

MANITOU		INTERIEUR INDOOR	EXTERIEUR OUTDOOR
2006/42 EC		Charge maxi Max. load	kg kg
MANITOU BF 44158 ANGENIS CEDEX FRANCE		No. personnes maxi Max. no. of persons	
MOBILE MOBILE		Equipment Attachement	kg kg
N° dans la série Serial no.		Forces motrices Motorial forces	kW kW
Année Fabrication Year of Manufacture	Année du Modèle Year of Model	Inclinaison maxi Max. tilt	° °
Masse à vide Empty weight		Vitesse maxi du vent Max. wind speed	m/s m/s
Puissance Power		Source électrique ext. Ext. electrical source	Volts
Tension Voltage			VDC

N° 835356

LOCATION OF THE MANUFACTURER'S PLATE (FIG. B – No. B1)

The manufacturer's plate is fastened inside the turret on the motor side.

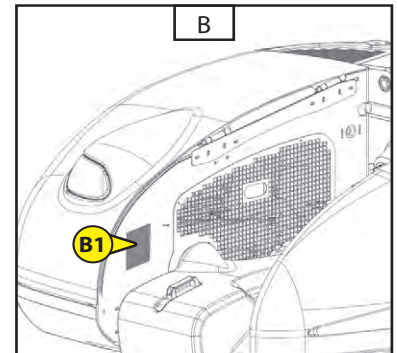

EWP ADDITIONAL INFORMATION PLATE (FIG. C)

- Model.
- Serial No.
- Date of commission.
- Design Registration No.

MANITOU	
EWP ADDITIONAL INFORMATION PLATE	
MANITOU BF 44158 ANGENIS CEDEX FRANCE	
MODEL	SERIAL NO.
DATE OF COMMISSION	Design Registration No.
<p>THIS ELEVATING WORK PLATFORM MEETS OR EXCEEDS THE APPLICABLE REQUIREMENTS OF AUSTRALIAN STANDARDS AS1181 PART 10 AS ORIGINALLY MANUFACTURED FOR THE INTENDED APPLICATIONS AND USE.</p> <p>OPERATION, INSPECTION AND MAINTENANCE MODIFICATIONS OR REPAIRS OF THIS MACHINE SHALL BE CARRIED OUT IN ACCORDANCE WITH AS3099-10 AND THE MACHINE MANUALS.</p>	
N° 834439	

LOCATION OF THE EWP ADDITIONAL INFORMATION PLATE (FIG. D – No. D1)

The EWP additional information plate is fastened inside the turret on the motor side and beside the manufacturer's plate..

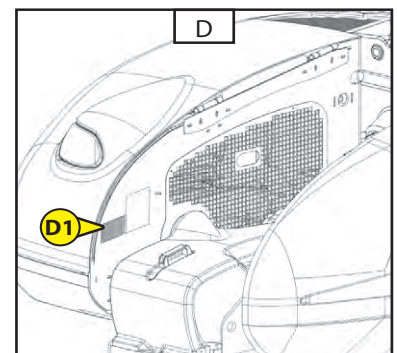

IC ENGINE (FIG. E - No. E1)

- Engine no.

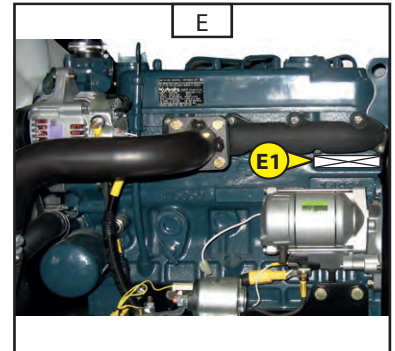

HYDROSTATIC PUMP (FIG. F)

- Pump No.
- Coding type
- Manufacture No
- Year of manufacture

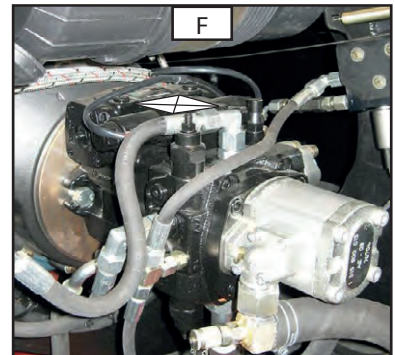

FRONT AXLE (FIG. G)

- Axle type
- Serial No.
- Manufacture No.

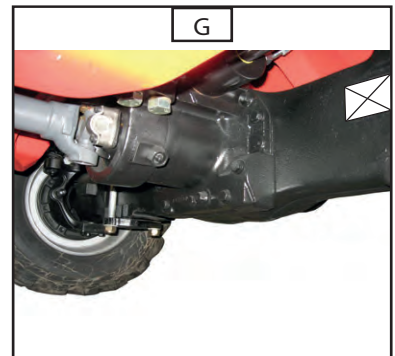

REAR AXLE (FIG. H)

- Axle type
- Serial No.
- Manufacture No.

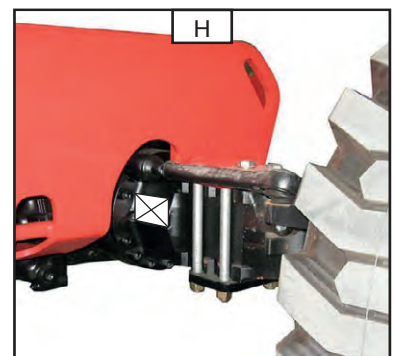

CHARACTERISTICS OF 160 ATJ E3 - 160 ATJ E3 RC - 160 ATJS E3

LOAD SPECIFICATIONS	UNIT	160 ATJ E3	160 ATJS E3	160 ATJ E3 Wheel 18"	TOL ±
Lifting platform					
Nominal capacity for use indoors	Kg	230			-
Nominal capacity for use outdoors	Kg	230			-
Max wind during outdoor use	km/h	45			-
No. of people in the basket during indoor/outdoor use		2			-
Maximum allowed manual horizontal force	daN	40			-
Turret rotation	°	355° / Continuous			
Lifting platform unladen weight	Kg	6160	5850	6460	25
Max permissible tilt	° - %	5 - 9			0,1
Traversable slope	%	40			2
Work speed	Km/h	0,8			0,1
Slow transport speed (1)	Km/h	2,5			0,2
Ramp transport speed (2)	Km/h	2.5			0,2
Fast transport speed (3)	Km/h	6.1	6.0	6.1	0,2
Wheels					
Tyres		CURED ON 830x285	33x12-20SKS SOLIDAIR	12,5 - 18 OPTIMIZER	
Inflation pressure	bar	Honeycomb PPS		Foam	
Overload radius, F/R transport position	mm	405/405		455/455	2
Load on one front wheel (transport position)	Kg	1465	1337	1540	20
Load on one rear wheel (transport position)	Kg	1615	1588	1690	20
Max load on one wheel, work position	Kg	3740	3740	3910	25
Contact surface on the ground (hard / soft ground)	Cm ²	267 / 620	325 / 602	290 / 780	20
Surface punch-through (hard / soft ground)	daN/cm ²	14.06 / 6.03	11.51 / 6.22	13.48 / 5.02	-
HYDRAULIC MOVEMENT (basket control)	UNIT	160 ATJ E3	160 ATJS E3	160 ATJ E3 Wheel 18"	TOL ±
Arms 1/2					
Raising unladen / laden	s	22 / 22			+2
Lowering unladen / laden	s	28 / 28			+5
Arm 3, telescope extended					
Raising unladen / laden	s	20 / 20			+2
Lowering unladen / laden	s	18 / 18			+2
Arm 3, telescope retracted					
Raising unladen / laden	s	14 / 14			+3
Lowering unladen / laden	s	14 / 14			+3
Telescope					
Extended unladen / laden	s	9 / 9			+2
Retraction unladen / laden	s	9 / 9			+2
Pendular arm					
Raising unladen / laden	s	20 / 20			+2
Lowering unladen / laden	s	18 / 18			+2
Turret rotation					
Rotation over 355°, telescope extended / retracted	s	92 / 72			+3
Basket rotation					
Rotation over 180°	s	13			+3

CHARACTERISTICS OF 160 ATJ E3 - 160 ATJ E3 RC - 160 ATJS E3

INTERNAL COMBUSTION ENGINE	UNIT	160 ATJ E3	160 ATJS E3	160 ATJ E3 Wheel 18"	TOL ±
Type		KUBOTA V1505-E3B			-
Fuel		Diesel			-
No. of cylinders		4			-
Idling speed, unladen	Cm3	1498			-
Max engine revs, unladen	rpm	1000			50
ISO power/ rpm (at 3000 rpm)	rpm	3000			20
Max torque (at 2300 rpm)	CV - KW	26,2			-
Fuel consumption per hour	Nm	92			-
No. of cycles / fuel consumption test	L/h	1,92			
Nbre cycles / test consommation carb.	No. of cycles / h	6			
Unladen weight	Kg	110			5
Air filtration	µm	-			-
Type of cooling		AIR			-
Fan		SUCTION			-
LwA acoustic pressure level	dba	102			-
TRANSMISSION	UNIT	160 ATJ E3	160 ATJS E3	160 ATJ E3 Wheel 18"	TOL ±
Type		HYDROSTATIC			
Hydrostatic pump		A10VG45			
Supplier		BOSCH-REXROTH			
Cylinder capacity	Cm3	46			
Max service pressure	bar	Dr 305			5 %
Hydrostatic motor		A2FM80			
Supplier		BOSCH-REXROTH			-
Cylinder capacity	Cm3	80			-
Axle		Type 26 - 20	Type 211 (front) Type 111 (rear)	Type 26 - 20	
Supplier		CARRARO	DANA	CARRARO	
Reduction ratio		42.97	44.02	42.97	
Traction power	daNm	3130	3300	2790	-
Front axle differential		SLIPPAGE LIMIT 45%			-
Rear axle differential		Hydraulic lock 100%			
No. of steered wheels, front / rear		2 / 2	2 / 0	2/2	
No. of driven wheels, front / rear		2 / 2			-
BRAKING CIRCUIT (parking brake)	UNIT	160 ATJ E3	160 ATJS E3	160 ATJ E3 Wheel 18"	TOL ±
Type of brake		Negative			-
Type of control		Hydraulic			-
Braked wheels		2 rear wheels			-
Brake release (freewheeling)		Manual, on axle			-
Braking torque	daNm	1600 at the wheel	-	1600 at the wheel	5 %
LEVEL OF VIBRATIONS	UNIT	160 ATJ E3	160 ATJS E3	160 ATJ E3 Wheel 18"	TOL ±
Quadratic average values for the body	m/s ²	< 0,5			-



CHARACTERISTICS OF 160 ATJ E3 - 160 ATJ E3 RC - 160 ATJS E3

HYDRAULIC CIRCUIT	UNIT	160 ATJ E3	160 ATJS E3	160 ATJ E3 Wheel 18"	TOL ±
Auxiliary hydraulic pump					
Type		fixed cubic capacity BOSCH			
Cubic capacity	Cm3	19			-
Max flow rate, unladen	l/min	57			-
Max permanent service pressure	bar	230	210	230	5
Filtration					
Return	µm	-			-
Suction	µm	100 (β10)			-
Pressure	µm	10			-

ELECTRICAL CIRCUIT	UNIT	160 ATJ E3	160 ATJS E3	160 ATJ E3 Wheel 18"	TOL ±
Battery					
C5 capacity	Ah	105			-
Nominal voltage	V	12			-
Type		Starting			-
Alternator					
Type		-			-
Intensity	A	40			-
Voltage	V	12			-
Starter					
Type		-			-
Power	Kw	-			-
Voltage	V	12			-

EMERGENCY PUMP	UNIT	160 ATJ E3	160 ATJS E3	160 ATJ E3 Wheel 18"	TOL ±
Type		Electric			-
Cubic capacity	Cm3	2,0			-
Power	Kw	1,3			-
Voltage	V	12			-
Intensity at 150 bars	A	-			-
Integral thermal cut-off		YES			
S2	min	6.2 min at 100 b			-
S3	%	10.3 % at 100 b			-



CHARACTERISTICS OF 160 ATJ E3 - 160 ATJ E3 RC - 160 ATJS E3

DIMENSIONS	UNIT	160 ATJ E3	160 ATJS E3	160 ATJ E3 Wheel 18"	TOL ±
Transport position					
Width	mm	2298	2320	2280	1%
Length	mm	6530		6580	1%
Length (truck transport)	mm	4440		4490	1%
Height	mm	2370		2420	1%
Floor / ground height, during transport	mm	370		420	1%
Turret overlap	mm	232	180	242	1%
Work position					
Working height	mm	16010		16060	1%
Floor height	mm	14010		14060	1%
Max offset, interior of basket	mm		7795		1%
Working offset	mm		8300		1%
Floor height, basket at max offset	mm	7505		7555	1%
Overhang under upper arm	mm	7380		7430	1%
Clearance under the chassis	mm	355		405	2%
Clearance under the axle	mm	260	275	310	2%
Max clearance angle under chassis	%	75		78	2%
INT. / EXT. radius of gyration, two-wheel	mm	2800 / 5600	2112 / 4990	2800 / 5600	3%
INT. / EXT. radius of gyration, four-wheel	mm		1390 / 3710		3%
Basket					
External volume	mm		1800 x 800		1%
Floor area	mm		1790 x 760		1%
CAPACITY	UNIT	160 ATJ E3	160 ATJS E3	160 ATJ E3 Wheel 18"	TOL ±
Hydraulic oil reservoir	l		54		2
Diesel tank	l		52		2
Engine oil sump	l		6.7		2
Coolant circuit	l		5		2
STANDARD EQUIPMENT	UNIT	160 ATJ E3	160 ATJS E3	160 ATJ E3 Wheel 18"	TOL ±
Hour counter			Standard		-
230V pre-configuration			Standard		-
Diesel level proportional display			Standard		-
Low fuel level / battery alarm			Standard		-
Dead Man's handle			Standard		-
Toolbox in the basket			Standard		-
User interface (diagnostic help)			Standard		-
Oscillating axle			Standard		-
OPTIONS	UNIT	160 ATJ E3	160 ATJS E3	160 ATJ E3 Wheel 18"	TOL ±
Audible beep on all movements			Option		-
Rotating flashing light			Option		-



CHARACTERISTICS OF 180 ATJ 2 E3 & 180 ATJ 2 E3 RC

LOAD SPECIFICATIONS	UNIT	180 ATJ 2 E3	180 ATJ 2 E3 Wheel 18"	TOL ±
Lifting platform				
Nominal capacity for use indoors	Kg	230		-
Nominal capacity for use outdoors	Kg			-
Max wind during outdoor use	km/h	45		-
No. of people in the basket during indoor/outdoor use		2		-
Maximum allowed manual horizontal force (1daN=1kg)	daN	40		-
Turret rotation	°	355° / Continuous		
Lifting platform unladen weight	Kg	7250	7550	20
Max permissible tilt	° - %	5-9		0,1
Traversable slope	%	40	33	2
Work speed	Km/h	0.8		0,1
Slow transport speed (1)	Km/h	2.5		0,2
Ramp transport speed (2)	Km/h	2.5		0,2
Fast transport speed (3)	Km/h	6.1	7.2	0,2
Wheels				
Supplier		SOLIDEAL		
Tyres		CURED ON 830x285	12,5 - 18 OPTIMIZER	
Inflation/Pressure	bar	Honeycomb PPS	Foam, 4 bar	
Front wheel - radius under load (static 1h, transport)	mm	405	455	2
Rear wheel - radius under load (static 1h, transport)	mm	405	455	2
Front/rear wheel - radius under dynamic load (transport)	mm	415	477	
Bearing circumference recorded	mm	2618	2999	
Load on a front wheel (transport position)	Kg	1763	1840	5
Load on a rear wheel (transport position)	Kg	1862	1935	5
Maximum load on a wheel, working position	Kg	4742	4845	5
Bearing surface on ground (hard/unconsolidated)	Cm ²	268 / 645	314/830	3
Indenting on ground (hard/unconsolidated)	daN/ cm ²	17.70 / 7.35	15.43 / 5.84	-
HYDRAULIC MOVEMENT (basket control)	UNIT	180 ATJ 2 E3	180 ATJ 2 E3 Wheel 18"	TOL ±
Arms 1/2				
Raising unladen / laden	s	22 / 22		5%
Lowering unladen / laden	s	28 / 28		5%
Arm 3, telescope extended				
Raising unladen / laden	s	27 / --		5%
Lowering unladen / laden	s	25 / --		5%
Arm 3, telescope retracted				
Raising unladen / laden	s	16 / --		5%
Lowering unladen / laden	s	16 / --		5%
Telescope				
Extended unladen / laden	s	14 / --		5%
Retraction unladen / laden	s	14 / --		5%
Pendular arm				
Raising unladen / laden	s	20 / 20		5%
Lowering unladen / laden	s	18 / 18		5%
Turret rotation				
Rotation over 350°, telescope extended / retracted	s	120 / 88		5%
Basket rotation				
Rotation over 180°	s	13		5%



CHARACTERISTICS OF 180 ATJ 2 E3 & 180 ATJ 2 E3 RC

INTERNAL COMBUSTION ENGINE	UNIT	180 ATJ 2 E3	180 ATJ 2 E3 Wheel 18"	TOL ±
Type		KUBOTA V1505-E3B		-
Fuel		Diesel		-
No. of cylinders		4		-
Cubic capacity	Cm3	1498		-
Idling speed, unladen	rpm	1000		50
Max engine revs, unladen	rpm	3000		20
ISO power/ rpm (at 3000 rpm)	CV - KW	26.2		-
Max torque (at 2300 rpm)	Nm	92		-
Fuel consumption per hour	L/h	1.92		
No. of cycles / fuel consumption test	No. of cycles / h	6		
Unladen weight	Kg	110		5
Air filtration	µm	-		-
Type of cooling		AIR		-
Fan		SUCTION		-
LwA acoustic pressure level	dba	104		-

TRANSMISSION	UNIT	180 ATJ 2 E3	180 ATJ 2 E3 Wheel 18"	TOL ±
Type		HYDROSTATIC		
Pump		A10VG45		
Supplier		BOSCH - REXROTH		
Cylinder capacity (hydraulic transmission)	Cm3	46		
Max service pressure	bar	Dr 305		5 %
Hydrostatic motor		A10FM63		
Supplier		BOSCH-REXROTH		
Cylinder capacity	Cm3	63		
Axle		Type 26 - 20		
Supplier		CARRARO		
Reduction ratio		52.36		
Traction power	daNm	3130	2790	-
Front axle differential		SLIPPAGE LIMIT 45%		
Rear axle differential		Hydraulic lock 100%		
No. of steered wheels, front / rear		2 / 2		
No. of driven wheels, front / rear		2 / 2		

BRAKING CIRCUIT (parking brake)	UNIT	180 ATJ 2 E3	180 ATJ 2 E3 Wheel 18"	TOL ±
Type of brake		Negative		
Type of control		Hydraulic		
Braked wheels		2 rear wheels		
Brake release (freewheeling)		Manual, on axle		
Braking torque	daNm	1600 at the wheel		5 %

LEVEL OF VIBRATIONS	UNIT	180 ATJ 2 E3	180 ATJ 2 E3 Wheel 18"	TOL ±
Quadratic average values for the body	m/s ²	< 0,5		-



CHARACTERISTICS OF 180 ATJ 2 E3 & 180 ATJ 2 E3 RC

CIRCUIT HYDRAULIC	UNIT	180 ATJ 2 E3	180 ATJ 2 E3 Wheel 18"	TOL ±
Auxiliary hydraulic pump				
Type		fixed Cubic capacity BOSCH		
Cubic capacity	Cm3	16		-
Max flow rate, unladen	l/min	48		-
Max permanent service pressure	bar	230		5 %
Filtration				
Return	µm	-		-
Suction	µm	100 (β10)		-
Pressure	µm	10		-

ELECTRICAL CIRCUIT	UNIT	180 ATJ 2 E3	180 ATJ 2 E3 Wheel 18"	TOL ±
Battery				
C5 capacity	Ah	105		-
Nominal voltage	V	12		-
Type		Starting		
Alternator				
Type		-		-
Intensity	A	40		-
Voltage	V	12		
Starter				
Type		-		-
Power	Kw	-		-
Voltage	V	12		-

EMERGENCY PUMP	UNIT	180 ATJ 2 E3	180 ATJ 2 E3 Wheel 18"	TOL ±
Type		Electric		-
Cubic capacity	Cm3	2.0		-
Power	Kw	1.3		-
Voltage	V	12		-
Intensity at 150 bars	A	-		-
Integral thermal cut-off		YES		
S2	mn	6.2 min at 100 b		-
S3	%	10.3 % at 100 b		-



CHARACTERISTICS OF 180 ATJ 2 E3 & 180 ATJ 2 E3 RC

DIMENSIONS	UNIT	180 ATJ 2 E3	180 ATJ 2 E3 Wheel 18"	TOL ±
Transport position				
Width	mm	2298	2280	1%
Length	mm	7591	7631	1%
Length (truck transport)	mm	5522	5562	1%
Height	mm	2472	2522	1%
Floor height	mm	305	355	1%
Tail swing	mm	232	252	1%
Work position				
Work height	mm	18120	18170	1%
Floor height	mm	16120	16170	1%
Maximum offset	mm	10038	10038	1%
Working offset - (int basket +500)	mm	10538	10538	1%
Platform height basket at maximum offset	mm	7395	7445	1%
Overhang under upper arm	mm	7405	7455	1%
Ground clearance under chassis 1	mm	355	405	2%
Ground clearance under chassis 2	mm	260	310	2%
Maximum angle under chassis	%	75	78	2%
Interior turning circle 2 wheels/4 wheels	mm	- / -	- / -	3%
Exterior turning circle 2 wheels/4 wheels	mm	1390 / 3710	1390 / 3710	3%
Basket				
External dimensions	mm	1800 x 800		1%
Floor area	mm	1790 x 760		1%

CAPACITY	UNIT	180 ATJ 2 E3	180 ATJ 2 E3 Wheel 18"	TOL ±
Hydraulic oil reservoir	l	54		2%
Diesel tank	l	52		2%
Engine oil sump	l	6.7		2%
Coolant circuit	l	5		2%

STANDARD EQUIPMENT	UNIT	180 ATJ 2 E3	180 ATJ 2 E3 Wheel 18"	TOL ±
Sound beep all movements		Option		
Flashing light/rotating beacon		Option		
Hour counter		Standard		
230V layout		Standard		
Diesel level proportional display		Standard		
Low fuel / battery level alarm		Standard		
Dead Man's pedal		Standard		
Basket toolbox		Standard		
User interface (diagnostic aid)		Standard		
Balanced axle		Standard		

DIMENSIONS 160 ATJ E3 - 160 ATJ E3 RC

A	6530
A1	4440
B	2200
C	2370
C1	2610
D	2298
E	355
F	260
G	1390
H	3710
J	5950
K	2730
L	370
M (radius under load)	405
X	37°

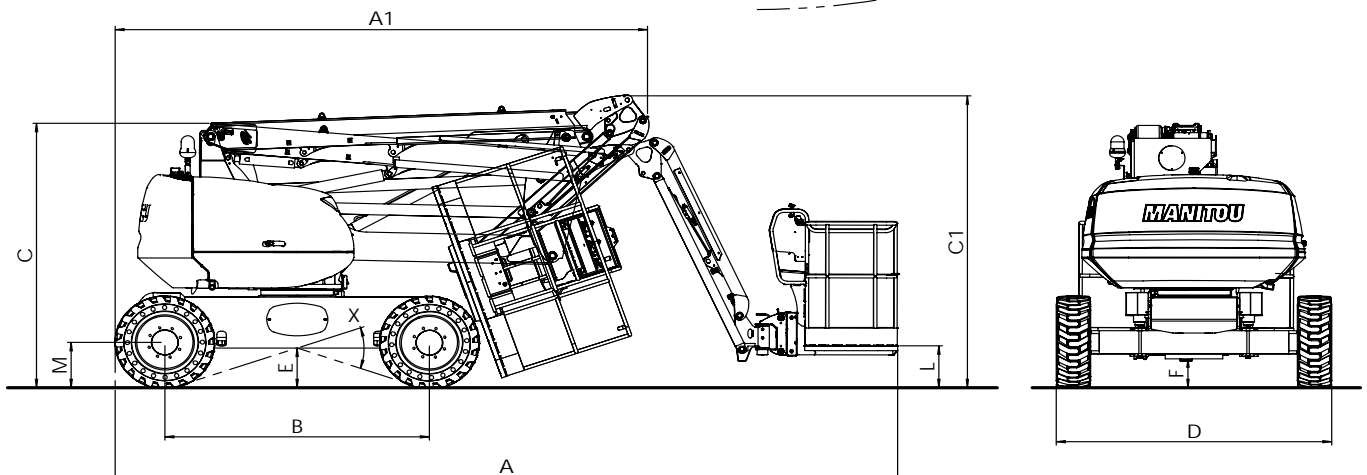
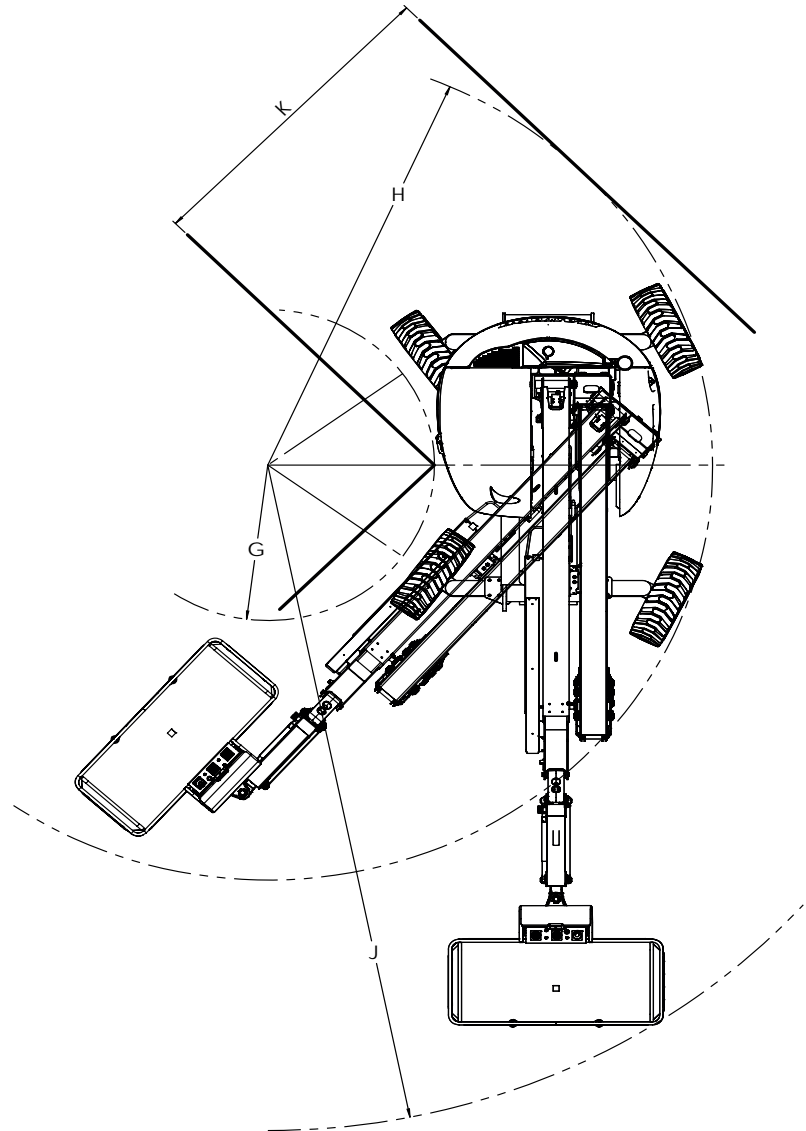

DIMENSIONS 160 ATJS E3

A	6530
A1	4440
B	2200
C	2370
C1	2610
D	2320
E	355
F	275
G	2112
H	4990
J	5734
K	3490
L	370
M	405
X	35.5°

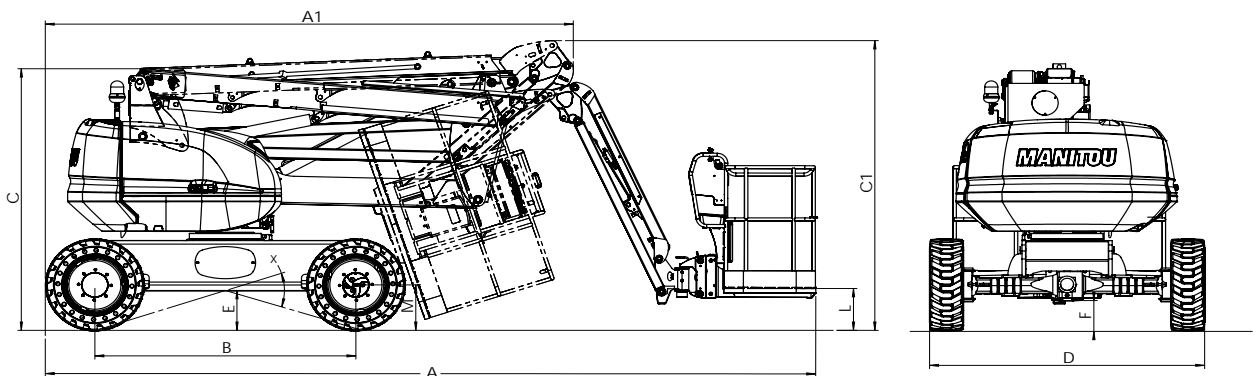
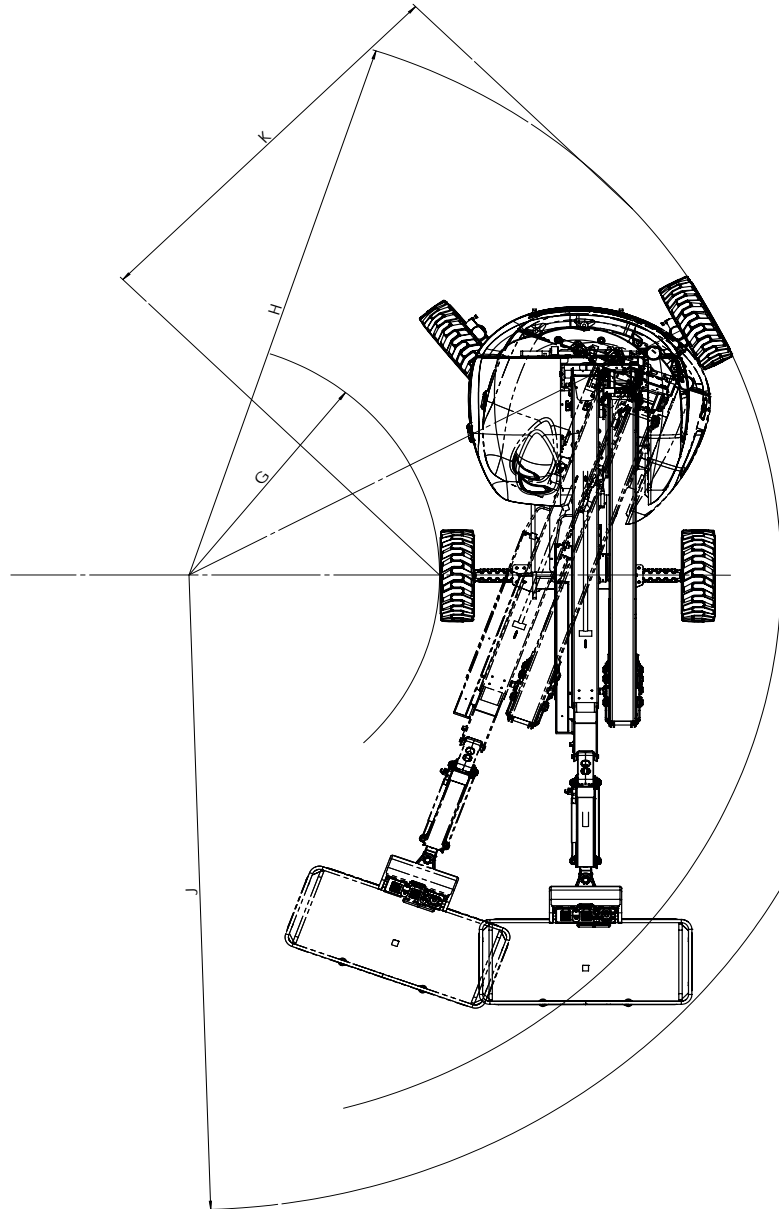

DIMENSIONS 180 ATJ 2 E3 & 180 ATJ 2 E3 RC

A	7591
A1	5522
B	2429
C	2472
C1	2610
D	2298
E	355
F	260
G	1390
H	3710
I	4528
J	6891
K	2730
L	316
M (radius under load)	405
X	37°

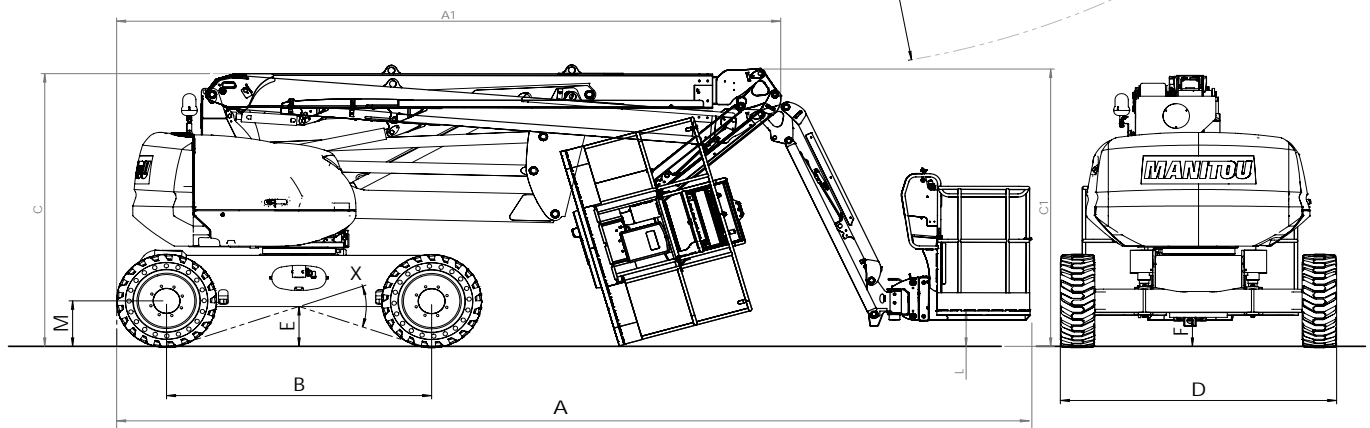
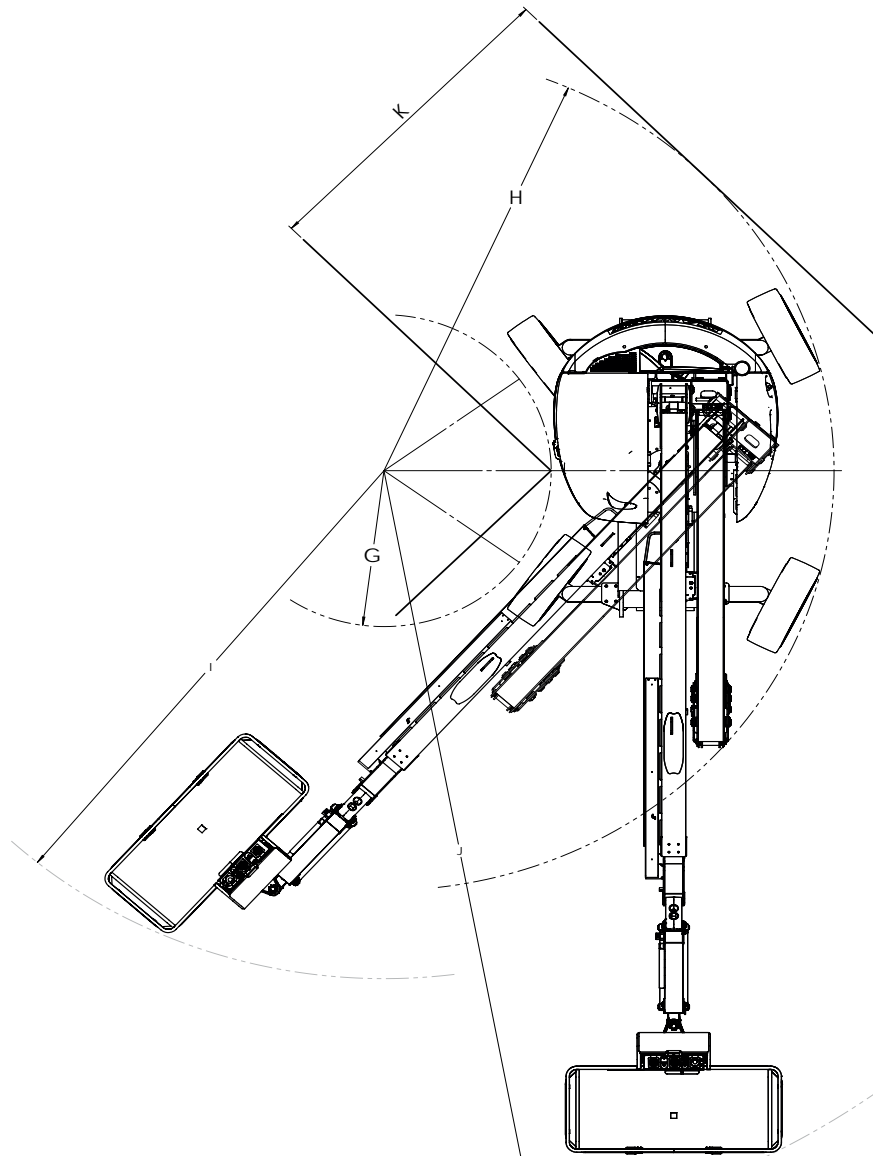





DIAGRAM 160 ATJ E3 - 160 ATJ E3 RC - 160 ATJS E3

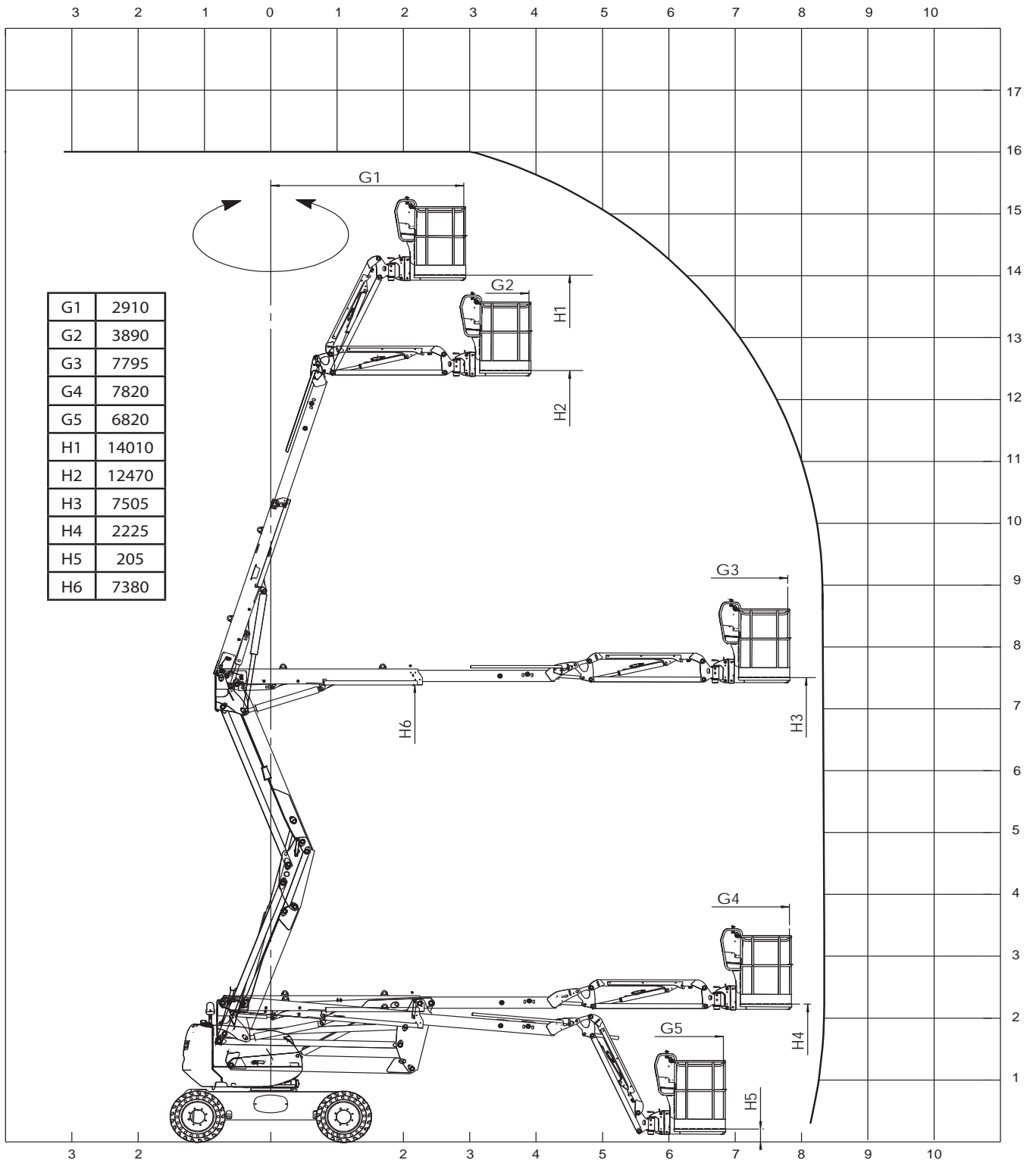
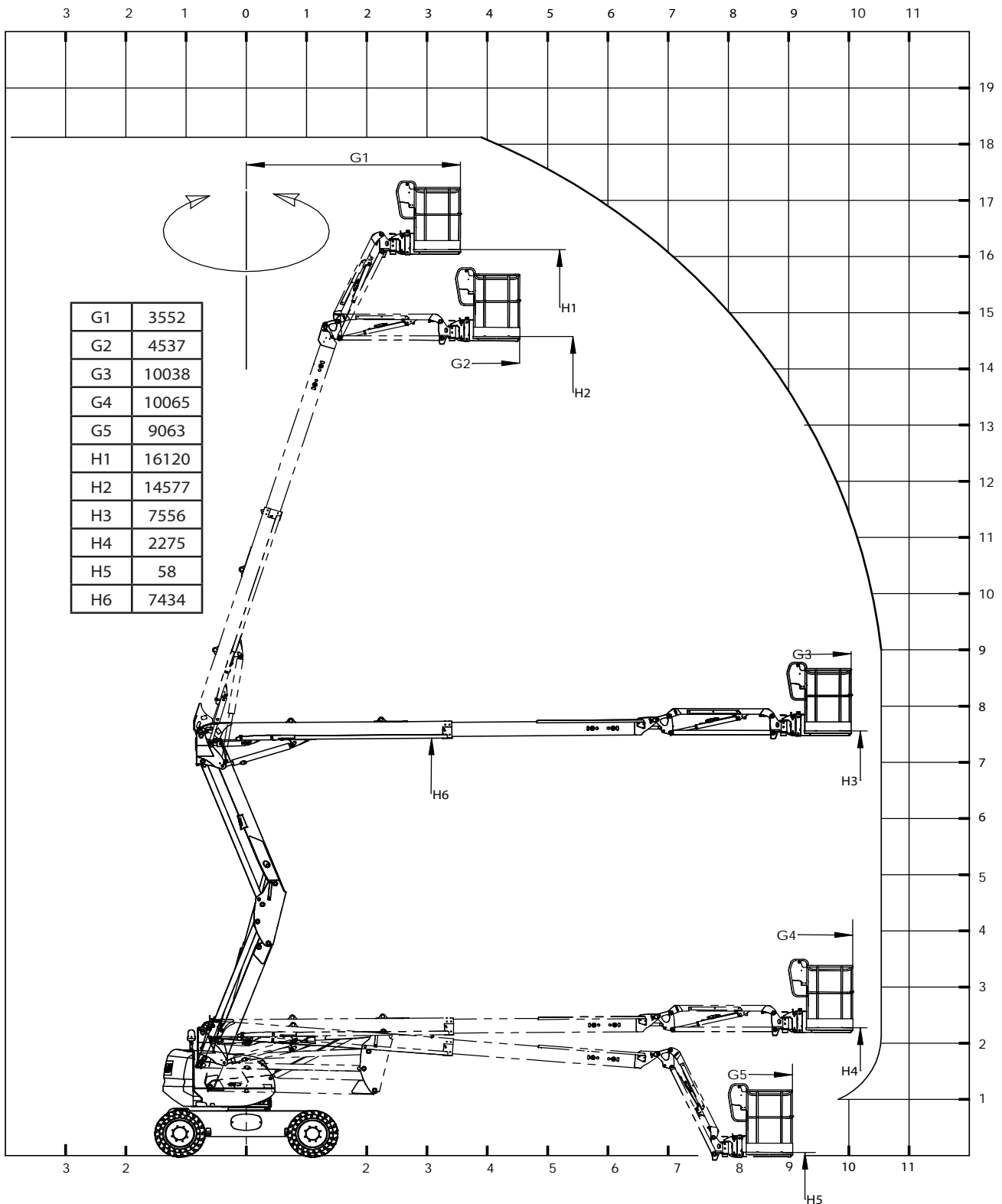



DIAGRAM 180 ATJ 2 E3 - 180 ATJ 2 E3 RC





LIFTING PLATFORM OPERATION

DESCRIPTION

- This is a mobile people-lifting platform. It consists of a working platform fixed on the end of a pendular arm, itself fixed to the end of a telescopic arm, the whole assembly being mounted on an articulated arm structure.
- MANITOU lifting platforms are solely intended to be used to carry people, with their tools and supplies (up to the authorized weight limit: see the "SPECIFICATIONS" section), to the desired working height, to reach difficult to access areas over installations and buildings.
- The lifting platform is fitted with controls in the basket. From this control station, the operator can drive and operate his machine forwards and backwards. The operator can also raise or lower the arm assembly, extend or retract the telescopic arm and turn the turret or the basket to the right or the left.
The basket, arm and turret assembly can rotate through 359 degrees, non-continuously or continuously depending on the type of lifting platform, to the right or left with respect to the parked position.
- The lifting platform is also fitted with a ground maintenance and emergency station, from which all the lifting commands can be made, except for translation commands. The base controls are only to be used for rescue purposes, to bring the operator back to the ground if he is incapable of returning there himself.
- The operator must check on a daily basis that the ground maintenance and emergency station controls, and then the basket controls, are working correctly.



Stickers showing the characteristics, safety warnings and the rescue procedure are affixed to the machine. The operator must read these and fully understand their content. To avoid any risk of wrongly interpreting the pictograms, please refer to the paragraph "SAFETY STICKERS" Section 1 – SAFETY INSTRUCTIONS AND ADVICE.

- The lifting platform's movements are provided by a hydraulic pump operated by the IC engine. The hydraulic components are controlled by electro-valves actuated by means of contactors on the control joy stick.
- The controls on the base console and the basket console are in the form of rocker switches are in either ON or OFF mode.
- **The base console is fitted with a so called "Dead man's" button Rep. 8*. This one must be maintained in base position simultaneously in the impulse of a base control. Releasing it stops the movement.**
- The lifting platform is a four-wheel drive machine driven by an IC engine. The drive wheels are fitted with spring brakes with hydraulic release. These brakes activate automatically as soon as the translation joy stick is returned to the Neutral position.
- The lifting platform can lift within the limits of its capabilities (see "SPECIFICATIONS" in this section). A load equal to or less than the maximum capacity in the basket enables you to move into any position provided that the machine is on a surface with a slope of no more than the maximum authorised inclination

GENERAL

- On the following pages, you will find all the information you require for using the machine. This included the procedures for using, driving, parking, loading and transporting the lifting platform.

SAFETY

TILT

When the lifting platform reaches the maximum authorised level of tilt (see the CHARACTERISTICS section), LED 35* on the basket console flashes regularly. Also the basket's buzzer 42* sounds intermittently. All the "AGGRAVATING" movements of raising the arms and extending the telescope are prohibited as a safety measure.



When recovering controls, only carry out de-aggravating movements:

- return to the safety position by retracting the telescope and lowering the arm, then reposition the access platform on more horizontal ground.

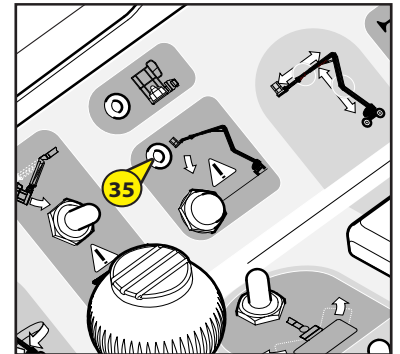

FRONT BRIDGE OSCILLATION LOCKING FAULT

- FROM THE PLATFORM No.951 458 AND THE PLATFORM No. 950 552

When the system detects a closing fault of the front bridge oscillation cylinders, the LED 35* on the control panel blinks rapidly and the warning buzzer is activated at a high frequency. All "DANGEROUS" arm lifting or telescopic movements are forbidden for safety reasons.



To regain control, only perform non-dangerous manoeuvres:

- return to a safe position by withdrawing the telescopic arm and lowering the arms.
- To re-enable lifting movements once the nacelle is returned to the "transport" position, cancel the fault by pressing "OK" 7c*.

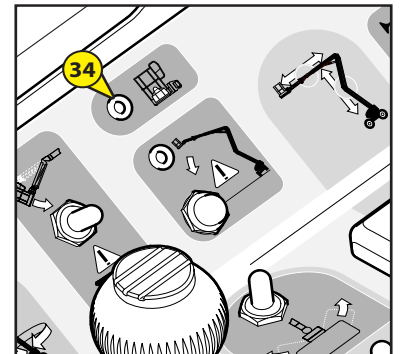

If the fault persists, contact your dealership.

OVERLOAD

When the lifting platform reaches the maximum authorised weight (see the CHARACTERISTICS section), the Overload LED 34* on the basket console flashes regularly. Also the basket's buzzer 42* sounds constantly. All movements are prohibited as a safety measure.



To resume control:

- Unburden the basket by removing the object or objects causing the overload,
- OR
- Ask a person on the ground to perform a descent under manual control (see paragraph "Rescue procedure" in chapter 2 and "Safety stickers" in chapter 1).

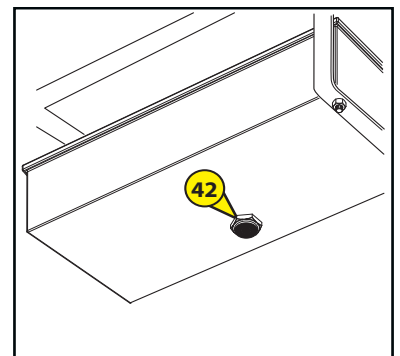

* : The above reference numbers also correspond to those used in the description of these components on the following pages.

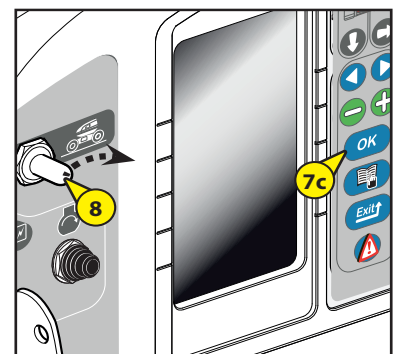

BASE CONTROL INSTRUMENTATION

A - GROUND MAINTENANCE AND EMERGENCY STATION

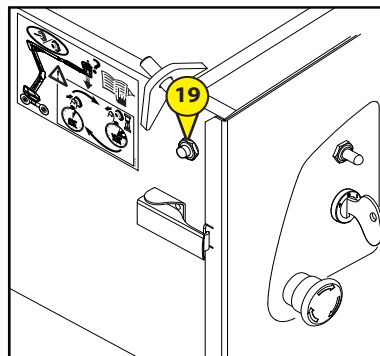
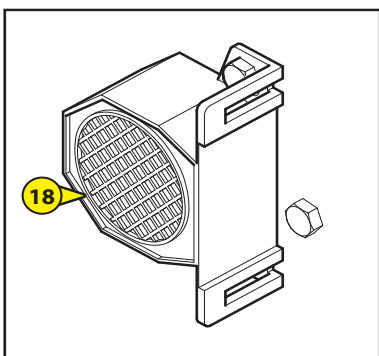
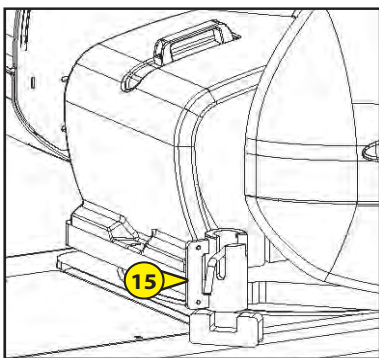
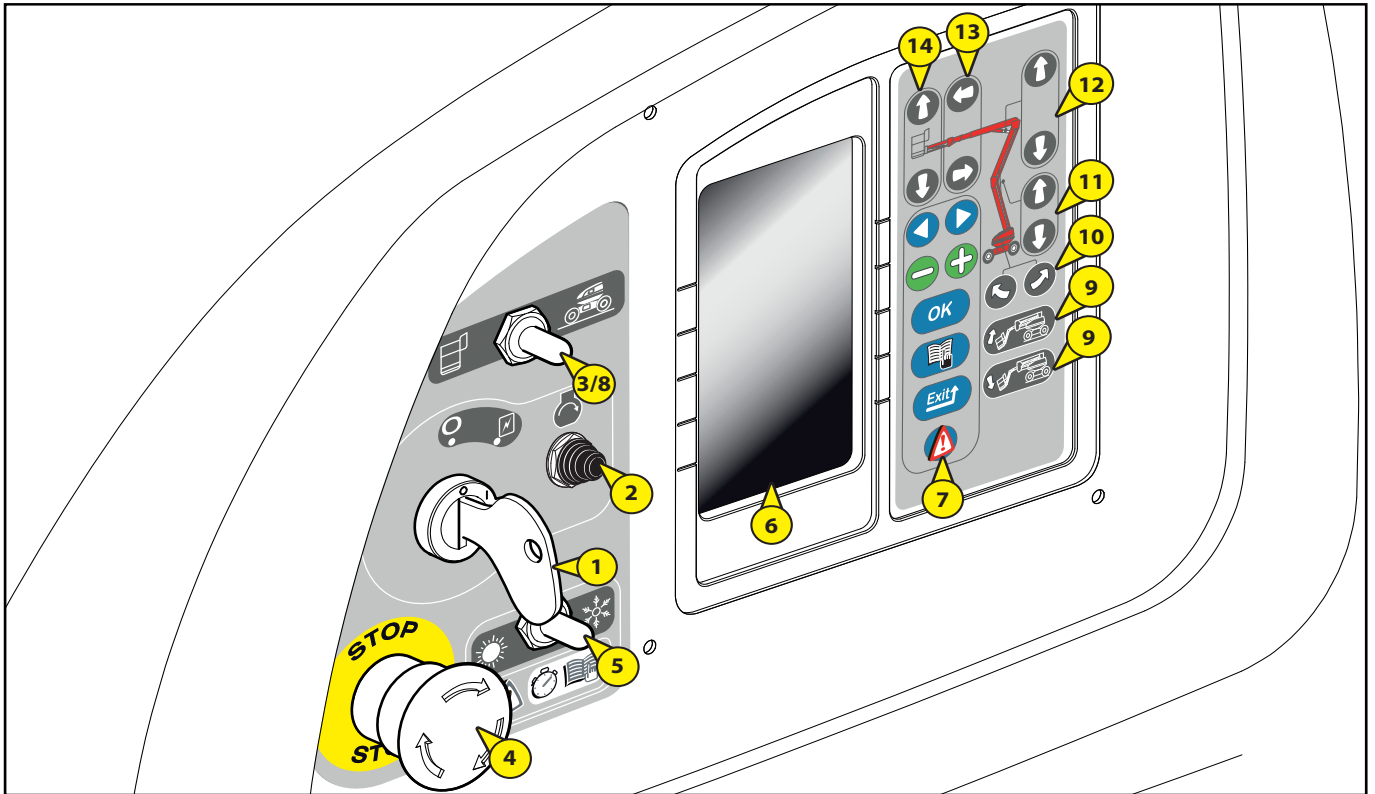



1 - KEY-OPERATED IGNITION SWITCH	2-32
2 - STARTER BUTTON	2-32
3 - GROUND OR PLATFORM CONTROL SELECTRO SWITCH	2-32
4 - EMERGENCY STOP	2-33
5 - ENGINE START-UP ASSISTANCE SELECTOR SWITCH	2-33
6 - INTERFACE SCREEN	2-34
7 - INFORMATION VALIDATION SCREEN KEYS	2-34
8 - DEAD MAN'S BUTTON	2-35
9 - BASKET TILT DOWN / TILT UP BUTTON	2-35
10 - TURRET ROTATION KEYS	2-35
11 - LOWER ARM UP / DOWN BUTTONS	2-36
12 - UPPER ARM UP / DOWN BUTTONS	2-36
13 - TELESCOPE EXTENSION / RETRACTION BUTTONS	2-36
14 - PENDULAR ARM UP / DOWN BUTTONS	2-36
15 - BLOCKING TURRET ROTATION	2-37
16 - FLASHING LIGHT	2-37
17 - TILT SENSOR	2-37
18 - BUZZER	2-37
19 - EMERGENCY PUMP BUTTON	2-38
20 - FUEL COCK	2-38

BASKET CONTROL INSTRUMENTATION

B - BASKET CONTROL STATION

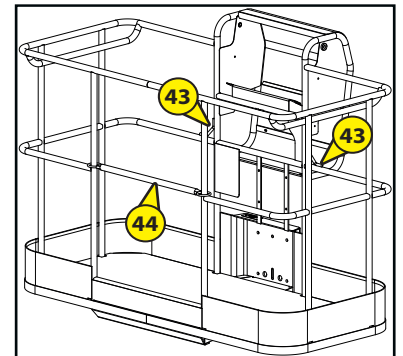
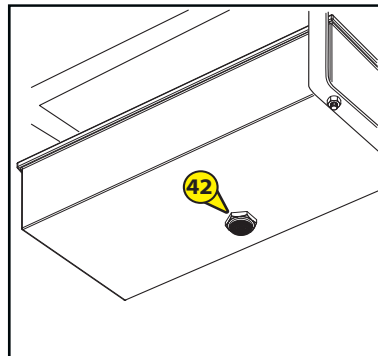
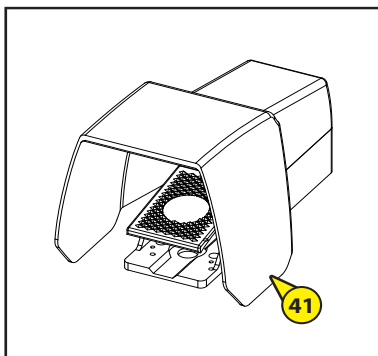
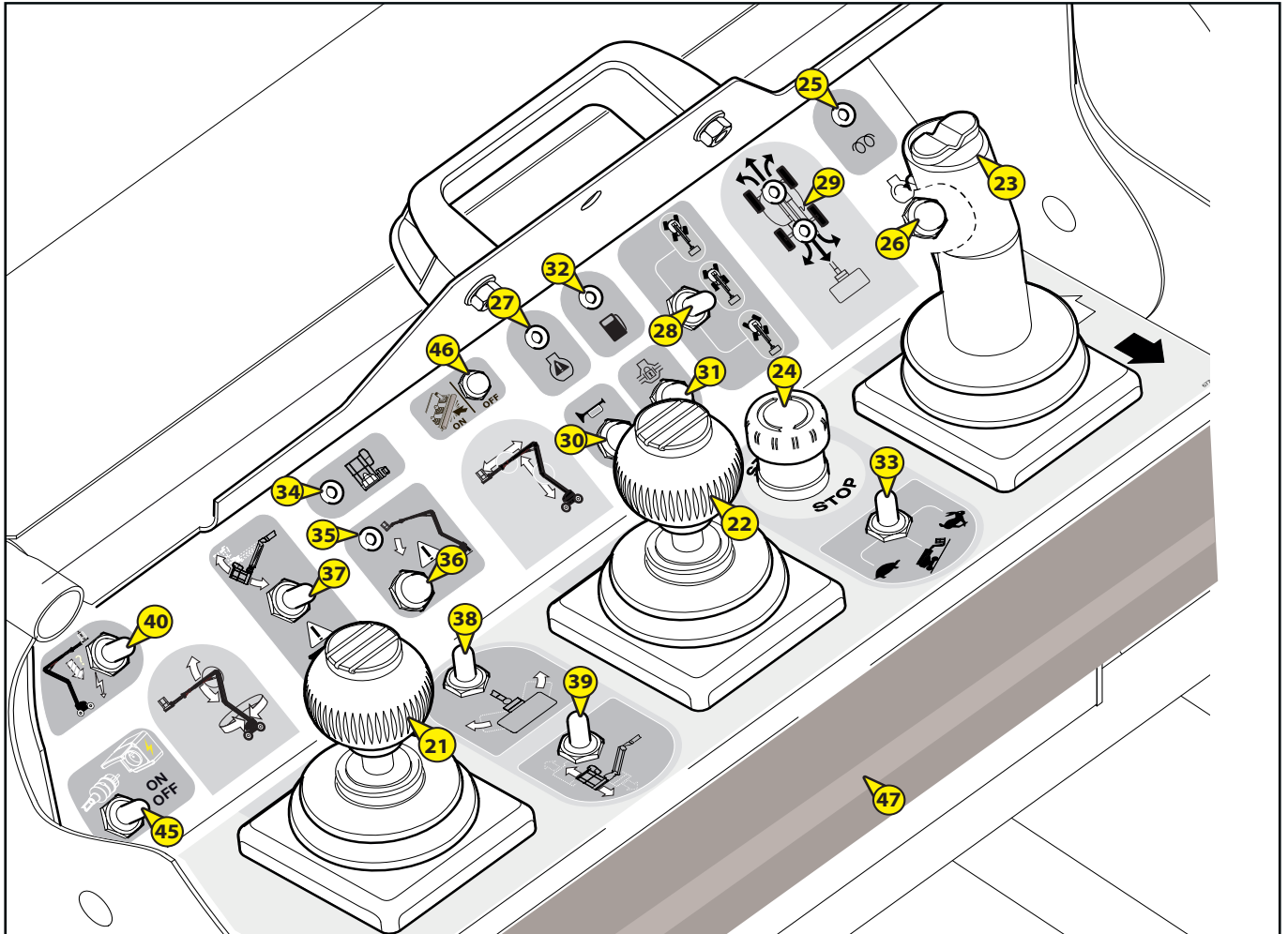



21 - UPPER ARM UP / DOWN AND TURRET ROTATION CONTROL LEVER	2-39
22 - LOWER ARMS UP / DOWN AND TELESCOPE EXTENSION / RETRACTION CONTROL LEVER	2-39
23 - CONTROL LEVER FOR PLATFORM FORWARD/REVERSE MOVEMENT	2-40
24 - EMERGENCY STOP	2-40
25 - "PREHEATING" INDICATOR LIGHT	2-41
26 - START-UP CONTROL BUTTON	2-41
27 - "ENGINE FAULT" LIGHT	2-41
28 - DIRECTION MODE SELECTOR	2-42
29 AXLE ALIGNMENT LEDS (except for 160 ATJ S)	2-42
30 - BUZZER CONTROL BUTTON	2-43
31 - DIFFERENTIAL LOCKING CONTROL BUTTON	2-43
32 - LOW FUEL LEVEL INDICATOR	2-43
33 - TRANSLATION SPEED SELECTION CONTACTOR	2-44
34 - "OVERLOAD" INDICATOR LIGHT	2-44
35 - "TILT" INDICATOR LIGHT	2-44
36 - "USE UNDER TILT" BUTTON	2-44
37 - BASKET INCLINATION CONTACTOR	2-44
38 - BASKET ROTATION CONTACTOR	2-45
39 - BASKET PENDULAR ARM CONTACTOR	2-45
40 - "EMERGENCY PUMP" BUTTON	2-45
41 - "DEAD MAN'S" PEDAL	2-45
42 - BUZZER	2-46
43 - SAFETY HARNESS HOOK-UP POINTS	2-46
44 - SAFETY RAIL	2-46
45 - GENERATOR ACTIVATION BUTTON OPTION)	2-46
46 - RÉARMING BUTTON (SAFEMANSYSTEM OPTION)	2-47
47 - SENSITIVE EDGE (SAFEMANSYSTEM OPTION)	2-47
48 - BLUE WARNING LIGHT (SAFEMANSYSTEM OPTION)	2-47

NB: The terms RIGHT-LEFT-FRONT-REAR are understood as being for an operator in the lifting platform looking forward with the platform in Transport position

GROUND MAINTENANCE AND EMERGENCY STATION

1 - KEY-OPERATED IGNITION SWITCH

This key-operated contactor has two positions.

POSITION 1

- Engine stop and electrical circuit supply off.

POSITION 2

- Electrical circuit supply on and automatic engine preheating.

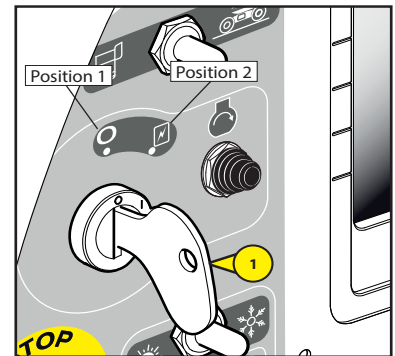

2 - STARTER BUTTON

BUTTON 2

- Engine start-up.

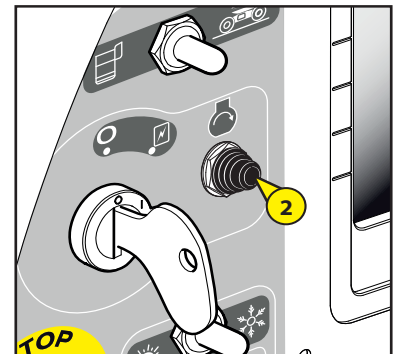

3 - GROUND OR PLATFORM CONTROL SELECTION SWITCH

This contactor has two positions.

POSITION 1

- The commands are given from the basket.

POSITION 2

- The commands come from the ground (base control). The button must be held down in position 2 (dead Man's system) to provide power to the base control. Releasing it prevents any movements from being made.

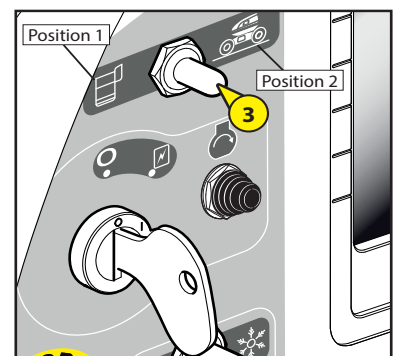

4- EMERGENCY STOP

This red mushroom-headed switch cuts off all the machine's movements in the event of an anomaly or any danger.

- Press the knob to cut off the movements.
- Turn the knob a quarter turn to the right to restore the power supply (the switch automatically returns to its initial position).



In all cases, this command takes precedence, even when the movements are being controlled from the basket control station.



If the Emergency Stop is activated, the movements may stop very suddenly.



Do not use the emergency stop to simply shut down the lifting platform. Otherwise, rearm it immediately as no action can be performed on the control panels at ground level or in the basket.

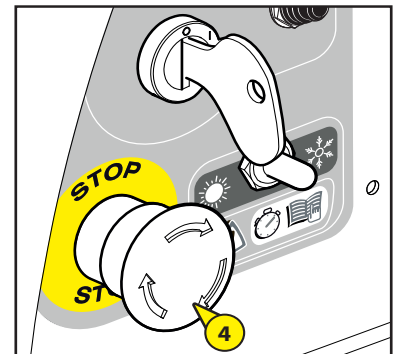

5 - LOW-TEMPERATURE ENGINE START-UP AID

This selector switch has two positions to be selected according to the ambient air temperature.

1 : SUN POSITION

- If the temperature is over - 10°C, start the engine at tickover rpm.

2 : SNOW POSITION

- If the temperature is less than around - 10°C, set the selector switch to this position before starting: the engine will be held at maximum rpm (only for the first start of the day).
- Leave the engine at maximum rpm for 30 to 60 seconds, depending on the temperature (no movement is possible during this time).
- Switch the selector switch from SNOW to SUN position and the rpm drop to tickover level (normal position, warm engine).

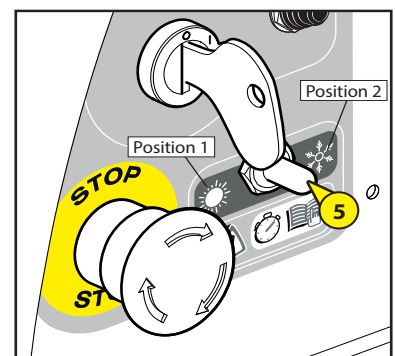



6 - INTERFACE SCREEN

- This screen lets you display all stages of start-up and parameters and access certain menus such as:
 - Maintenance display,
 - Machine maintenance,
 - Faults display,
 - Faults history,
 - Hour metres: internal-combustion engine meter, certain usage time sub-meters, daily usage meter, function activation meter (manufacturer access only).
- NOTE:
 - The current system time is displayed at the top of each page.
 - The serial number of the machine is displayed at the bottom of each page.

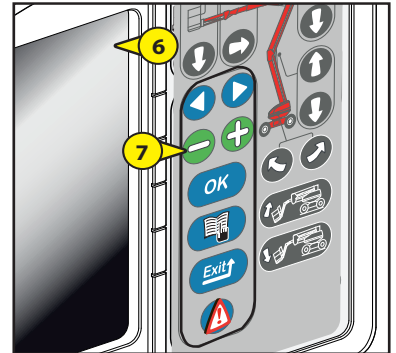

7 - INFORMATION VALIDATION SCREEN KEYS

- These keys enable you to validate the different information on the screens.

FUNCTIONS OF THE KEYBOARD KEYS:

7A : Selection keys for the proposals on the menu pages.

7B : Selection keys for the proposals on the sub-menu pages.

7C : This "Confirm / OK" key has two functions:
 "Confirmation" key for the selections made by the plus / minus keys,
 Fault acknowledgement key (the fault has been seen; this key enables you to get rid of the screen without necessarily resolving the problem).

7D : This "Menu" key has two functions:
 It enables you to open the "Access Menu" page.
 Enter the code to get the desired menu (this code will be memorised for as long as the lifting platform is receiving power).
 It enables you to exit and return to the work screen page.

7E : The "Exit" key has two functions:
 It cancels a validation in progress.
 It enables you to return to the previous level in a menu.

7F : The "Fault" key displays any faults present on the lifting platform when the fault triangle appears.

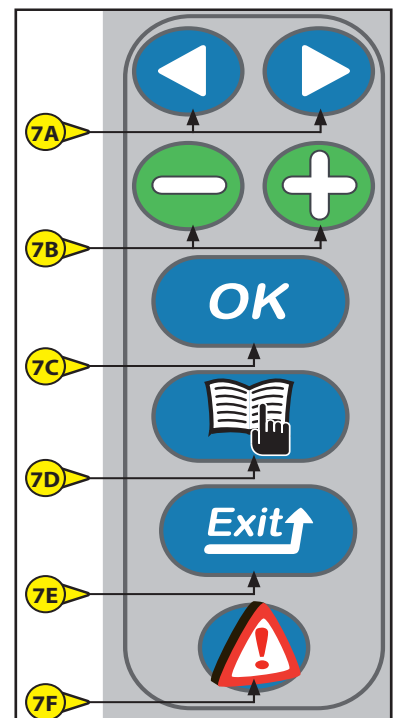

8 - "DEAD MAN'S" FUNCTION

- The button must be held down in the Dead Man's position (position 2) to provide power to the base control, at the same time as holding down the lifting and rotation keys.

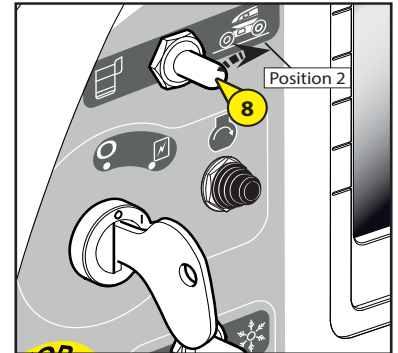

9 - BASKET TILT DOWN / TILT UP BUTTON

Using these keys at the same time as pressing button 8 to the Dead Man's position, control correction of the basket's horizontality or the complete folding back of the basket in Transport position.

9A : TILTING THE BASKET DOWNWARDS

- Hold down the Dead Man's button 8 and press key 9A.

9B : TILTING THE BASKET UPWARDS

- Hold down the Dead Man's button 8 and press key 9B.

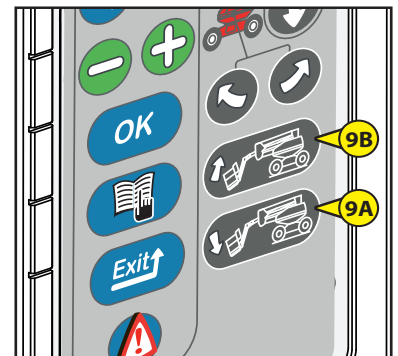

10 - TURRET ROTATION KEYS

Using these keys at the same time as pressing button 8 to the Dead Man's position, enable you to rotate the turret.

10A : ROTATING THE TURRET LEFT

- Hold down the Dead Man's button 8 and press key 10A.

10B : ROTATING THE TURRET RIGHT

- Hold down the Dead Man's button 8 and press key 10B.

- Maintenir la touche homme mort 8 et appuyer sur la touche 10B.

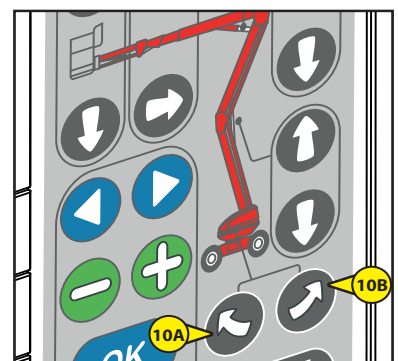



11 - LOWER ARM LIFTING AND LOWERING KEYS

- Using these keys at the same time as pressing button 8 to the Dead Man's position enables the lower arms to be lifted and lowered.

A : LIFTING THE LOWER ARMS

- Hold down the Dead Man's function 8 and press key 11A.

B: LOWERING THE LOWER ARMS

- Hold down the Dead Man's function 8 and press key 11B.

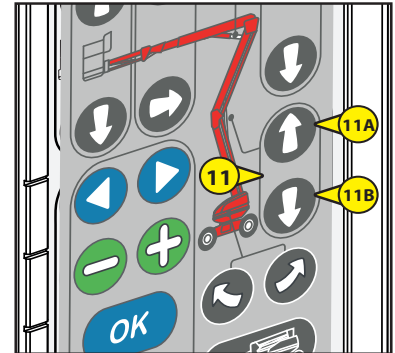

12 - UPPER ARM LIFTING AND LOWERING KEYS

- Using these keys at the same time as pressing button 8 to the Dead Man's position enables the upper arm to be lifted and lowered.

A : LIFTING THE UPPER ARM

- Hold down the Dead Man's function 8 and press key 12A.

B: LOWERING THE UPPER ARM

- Hold down the Dead Man's function 8 and press key 12B.

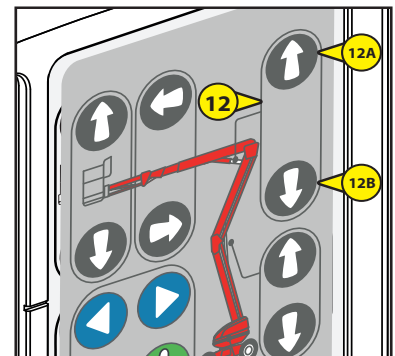

13 - TELESCOPE EXTENSION AND RETRACTION KEYS

- Using these keys at the same time as pressing button 8 to the Dead Man's position enables the telescope to be extended and retracted.

A : EXTENDING THE TELESCOPE

- Hold down the Dead Man's function 8 and press key 13A.

B : RETRACTING THE TELESCOPE

- Hold down the Dead Man's function 8 and press key 13B.

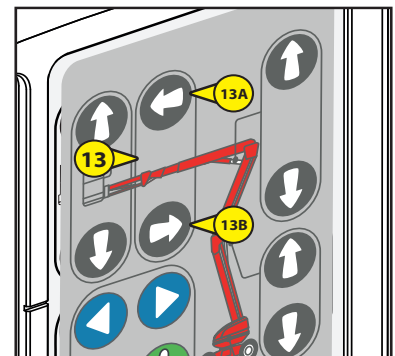

14 - PENDULAR ARM LIFTING AND LOWERING KEYS

- Using these keys at the same time as pressing button 8 to the Dead Man's position enables the pendular arm to be lifted and lowered.

A : LIFTING THE PENDULAR ARM

- Hold down the Dead Man's function 8 and press key 14A.

B: LOWERING THE PENDULAR ARM

- Hold down the Dead Man's function 8 and press key 14B.

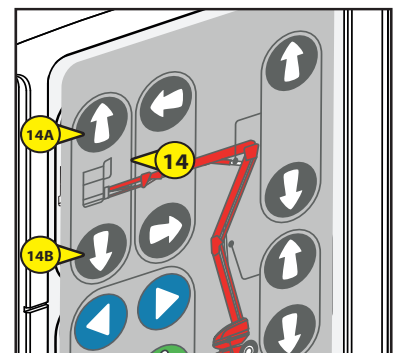

15 - BLOCKING TURRET ROTATION

- This pin must be used when the lifting platform is being transported by truck or some other means of transport (train, etc...), to prevent the turret from rotating.
- Swivel the pin to the left.
- Push the pin into the hole in the turret provided for this purpose.



Remember to remove it when using the lifting platform.e.

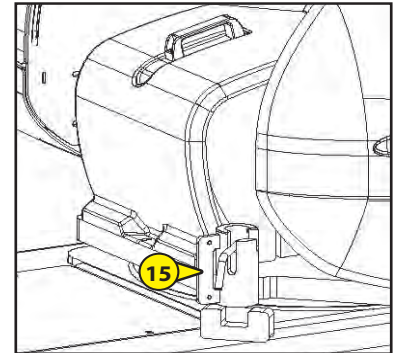

16 - FLASHING LIGHT

- The flashing light illuminates automatically when the lifting platform is in translation or making a movement.



17 - TILT SENSOR

- This sensor controls the safety buzzer 41 when the lifting platform has reached the maximum authorised level of tilt. The buzzer sounds intermittently (see the "SAFETIES" section).
- Two LEDs located under the tilt sensor 17A show its operating status:
 - Red LED lit: maximum permissible tilt not yet reached.
 - Yellow and red LEDs lit: maximum permissible tilt reached.

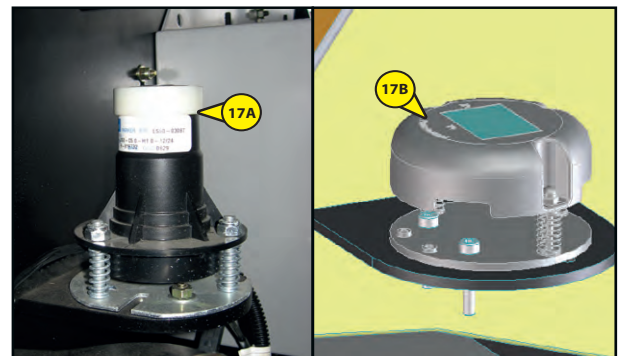

18 - BUZZER

- This buzzer (fixed on the outside of the hydraulic box, next to the telescopic arm) is activated when you press push-button 29 on the basket control station.

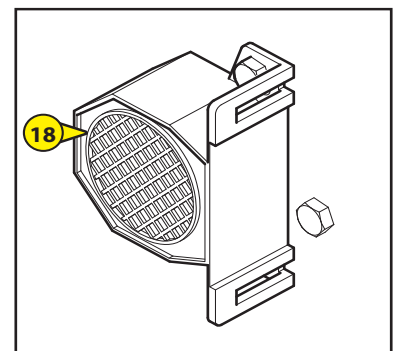

19 - BASE EMERGENCY PUMP BUTTON

- This button starts the emergency pump, which enables you to make all the basket's movements and return to the ground in the event of a breakdown occurring (see the: RESCUE PROCEDURE section).



Only use this if the engine or the electrical system has broken down.

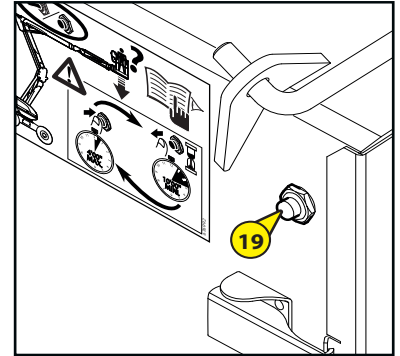

20 - FUEL COCK

- The fuel cock (20) located on the diesel filter must be in the "ON" position as shown opposite before starting the engine.
- The "OFF" position on the fuel cock shuts off the fuel supply to the engine.

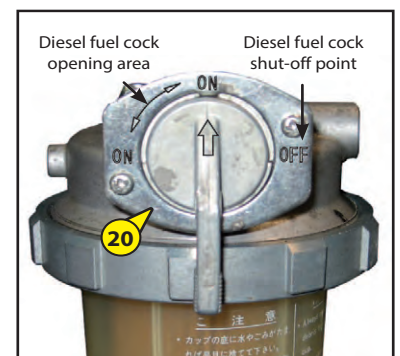

BASKET CONTROL STATION

21 - UPPER ARM UP / DOWN AND TURRET ROTATION CONTROL LEVER

- Lever 21 enables you to raise the upper arm and rotate the turret.

NB: This is a progressive control lever, which provides you with great accuracy in approach. It must be manipulated flexibly, without jerking.

RAISING THE UPPER ARM

- Push the lever upwards.

LOWERING THE UPPER ARM

- Pull the lever downwards.

ROTATING RIGHT

- Push the lever to the right.

ROTATING LEFT

- Push the lever to the left.

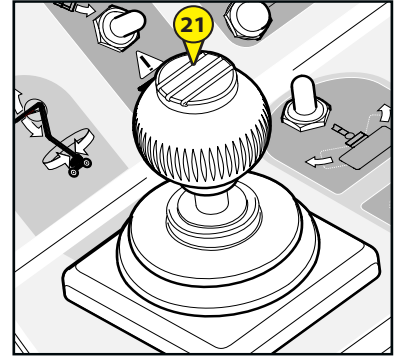

22 - LOWER ARMS UP / DOWN AND TELESCOPE EXTENSION / RETRACTION CONTROL LEVER

- Lever 22 enables you to raise the platform's lower and intermediate arms and extend and retract the telescope.

NB: This is a progressive control lever, which provides you with great accuracy in approach. It must be manipulated flexibly, without jerking.

RAISING THE LOWER ARMS

- Push the lever upwards.

LOWERING THE LOWER ARMS

- Pull the lever downwards.

EXTENDING THE TELESCOPE

- Push the lever to the left.

RETRACTING THE TELESCOPE

- Push the lever to the right.

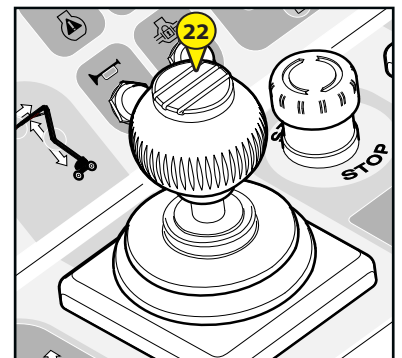



23 - LIFTING PLATFORM FORWARD / REVERSE AND RIGHT / LEFT MOVEMENT CONTROL

JOYSTICK

- Lever 23 enables you to move the lifting platform.
- You must press trigger A together with the Dead Man's pedal (see 41) to perform movements from the lifting platform's control box.
- When the pedal or trigger A is released, no commands can be issued.

NB: This is a progressive control lever, which provides you with great accuracy in approach. It must be manipulated flexibly, without jerking.

FORWARD TRANSLATION

- Push the lever forwards.

REAR TRANSLATION

- Pull the lever backwards.

STEER RIGHT

- Press button D.

STEER LEFT

- Press button G.

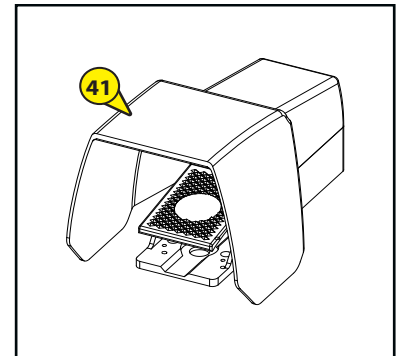
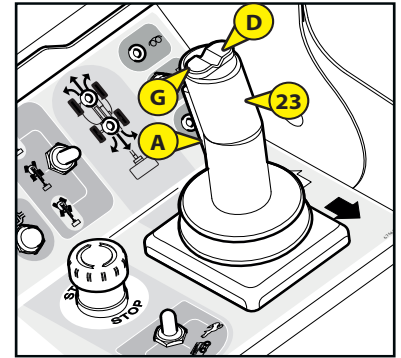

When the turret / arm structure is rotated more than 90° with respect to the chassis, there is a correspondence between the direction of translation shown by the arrows affixed to the chassis and those on the basket control console (white and black arrows). Always refer to the arrows shown on the machine's chassis to know the direction of movement.

24 - EMERGENCY STOP

- This switch enables you to cut off all the machine's movements in the event of an anomaly or danger arising.
- Press the knob to cut off all movements.
- Turn the knob a quarter turn to the right to deactivate it (the switch will automatically return to its initial position).



In all cases, this control has priority; except when movements are being made from the base control station.



Do not use the emergency stop to simply shut down the nacelle, otherwise, rearm it immediately as no action can be performed on the control panel in the basket.



To obtain a return to the ground in spite of this engaged basket emergency stop, use the emergency controls (see § Rescue procedure).

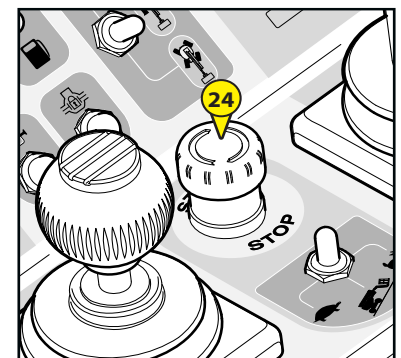

25 - "PREHEATING" INDICATOR LIGHT

This indicator light illuminates when the machine is supplied with power:

- Either by turning the ignition key on the base (the timing is identical to that shown on the bar graph on the screen).
- Or by rearming the Emergency Stop on the basket console in the lifting platform.
- Wait until the indicator light goes out before operating the starter button.

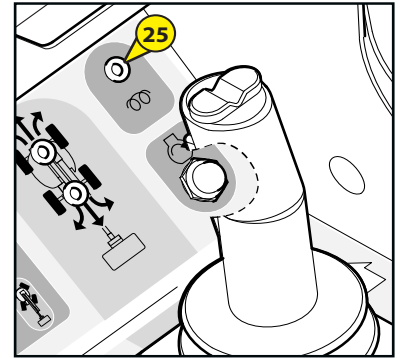

26 - START-UP CONTROL BUTTON

- Wait for the "Preheating" light to go out and then press button 26 to start the lifting platform from the basket console.

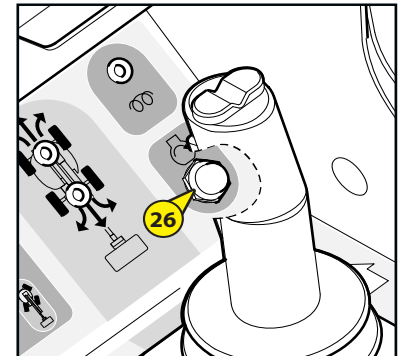

27 - "ENGINE FAULT" LIGHT

- This indicator light comes on and a short intermittent signal sounds.
- Descend quickly to the ground before automatic engine switch-off.

Problem:

- | | |
|----------------------------|--|
| - Engine oil pressure | : 90 seconds before engine switch-off. |
| - Engine water temperature | : 90 seconds before engine switch-off. |
| - Engine over-revving | : Immediate engine switch-off. |
- Stop the engine immediately.

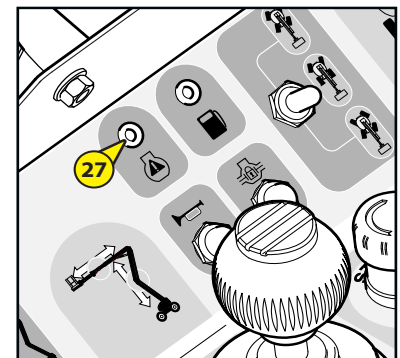



28 - 29 STEERING MODE SELECTOR AND AXLE REALIGNMENTS

This selector has three positions.

POSITION P1

- Select "Crab" mode.

POSITION P2

- Select 2-wheel drive mode.

POSITION P3

- Select 4-wheel drive mode. In this configuration, the only translation speeds are Slow or Ramp.

29A FRONT WHEEL ALIGNMENT

- This indicator light illuminates when the front wheels are correctly aligned with the machine's axis.

29B REAR WHEEL ALIGNMENT

- This indicator light illuminates when the rear wheels are correctly aligned with the machine's axis.

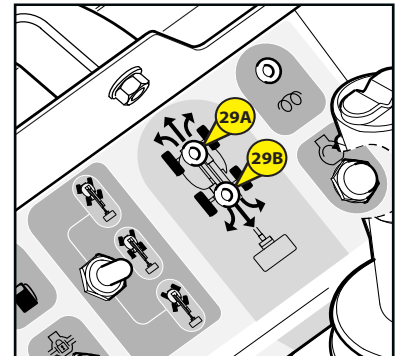
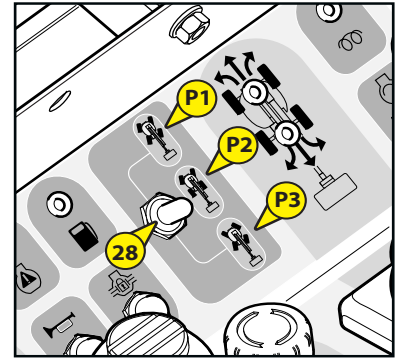

30 - BUZZER CONTROL BUTTON

- When you press button 30, buzzer 18 sounds.

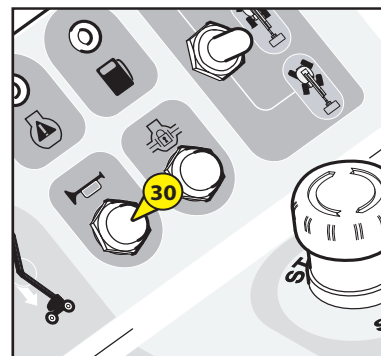

31 - DIFFERENTIAL LOCKING CONTROL BUTTON

NB: This control must be used at the same time as a translation operation.

Differential locking enables the 2 rear drive wheels to turn at the same speed.

- To use this, press button 31 and release the button to interrupt its use and note a stop in the translation movement.
- Preferably use differential locking while keeping the wheels in the machine's axis.

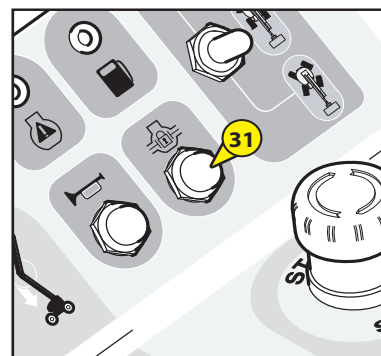

32 - LOW FUEL LEVEL INDICATOR

- This indicator light illuminates when the fuel level is low and the basket buzzer is activated :

- Level 1 of alarm: 3 beeps every 10 minutes, is approximately 5 hours of autonomy
- Level 2 of alarm: 3 beeps the every 1 minute, is approximately 3 hours of autonomy
- Level 3 of alarm: 3 beeps every 10 seconds, is approximately 2 hours of autonomy and blocking of the movements rises after 5 seconds of activation et blocage des mouvements élévations après 5 secondes d'activation.

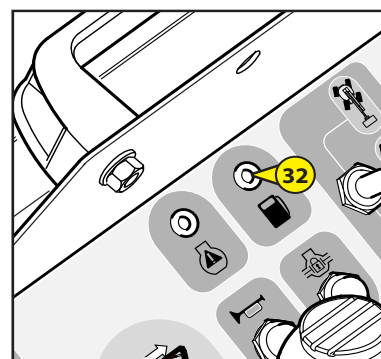

33 - TRANSLATION SPEED SELECTION CONTACTOR

- This contactor has 3 positions.

POSITION 1 : TORTOISE (SLOW SPEED)

POSITION 2 : RAMP (SLOW SPEED WITH FULL POWER) Only if crossing a very steep ramp.

POSITION 3 : HARE (HIGH SPEED), only with the steering mode selector switch in position 1 (28: Movement crabwise) or in position 2 (27: Movement in 2-wheel drive).

NB: When the selector switch is in **position 3** (high speed) and the machine is in **4-wheel drive**, the switch moves automatically to **position 2** (ramp speed).



While in Hare/high speed mode (position 3), the turret must be in the machine's axis.

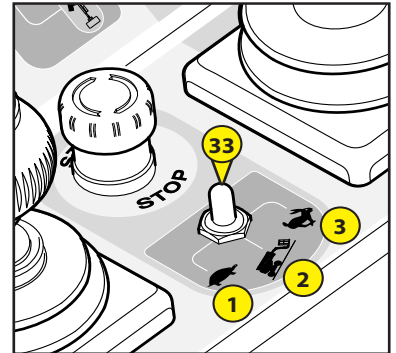

34 - "OVERLOAD" INDICATOR LIGHT

- This indicator light illuminates if the basket is overloaded and the buzzer sounds continuously (see the SAFETY SYSTEMS section)

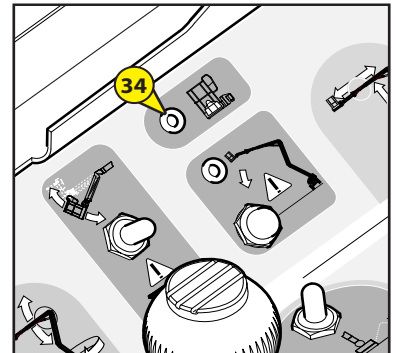

35 - "TILT" INDICATOR LIGHT

- When the lifting platform reaches the maximum authorised tilt, the LED lights up, any movements to raise the arms are blocked and the buzzer sounds with intermittent long beeps.

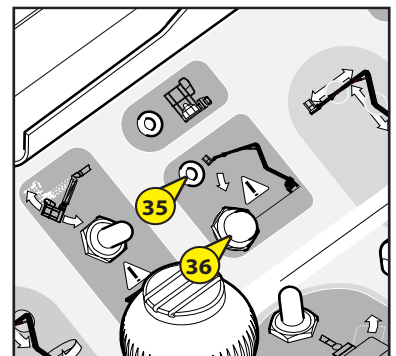

36 - "USE UNDER TILT" BUTTON

- This button enables you to utilise the prohibition on movements when the lifting platform is tilting (see the SAFETY SYSTEMS section").



When using the platform when it is tilting, there is a risk of loss of stability. The basket overload safety system still remains active.

37 - BASKET INCLINATION CONTACTOR

- This contactor enables you to correct the basket's horizontality or to fold the basket back completely in Transport position.

CORRECTING THE BASKET UPWARDS

- Push the contactor up.

CORRECTING THE BASKET DOWNWARDS

- Pull the contactor down.

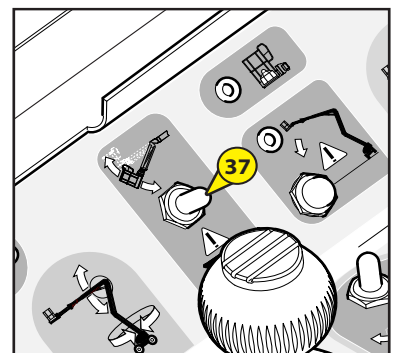

38 - BASKET ROTATION CONTACTOR

- This contactor enables you to rotate the basket left and right

RIGHT ROTATION

- Push the contactor to the right.

LEFT ROTATION

- Push the contactor to the left.

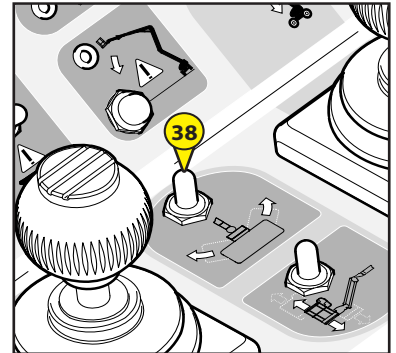

39 - BASKET PENDULAR ARM CONTACTOR

- This contactor enables you to raise and lower the pendular arm.

RAISING THE PENDULAR ARM

- Push the contactor forwards.

LOWERING THE PENDULAR ARM

- Pull the contactor backwards.

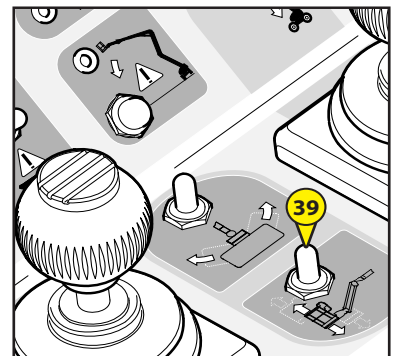

40 - "EMERGENCY PUMP" BUTTON

- This button enables you to make all the basket's movements to bring it back to the ground in the event of a breakdown (see the RESCUE PROCEDURE section).



Only to be used if the engine or electrical system breaks down.



Check the engine battery's charge; this must be charged, otherwise the emergency pump cannot be operated.

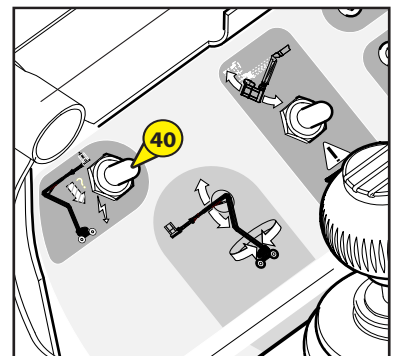

41 - "DEAD MAN'S" PEDAL

- This pedal is fixed to the lifting platform's floor.
- You must push this pedal to perform movements from the basket console.
- When the pedal is released, no commands can be issued.

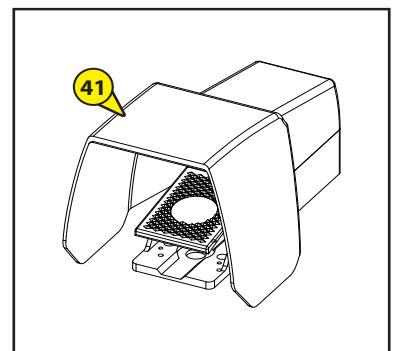

42 - BUZZER UNDER THE BASKET CONSOLE

- This buzzer is activated when the machine reaches the maximum authorised level of tilt or is overloaded.
- Sounding intermittently: the machine is tilting. When the authorised tilt limit threshold is crossed, all movements are blocked except for lowering the arms to enable return to an acceptable level.
- Sound continuously: the machine is overloaded. When the platform is overloaded, all movements are blocked. It is essential to unburden the machine so that you can manoeuvre.

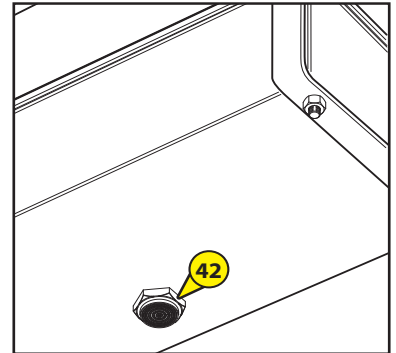

43 - SAFETY HARNESS HOOK-UP POINTS

- These fittings are to be used for fastening the harnesses when operators are in the basket.

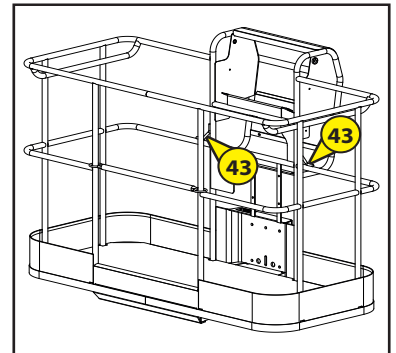

44 - SAFETY RAIL

- You must hold the rail to climb into the basket so that the rail does not fall back as the operator climbs in.



Do not hold the safety rail with a collar or string.



45 - GENERATOR ACTIVATION BUTTON (OPTION)

- See the "DESCRIPTION AND USE OF THE OPTIONS" Section, page 2-61



46 - REARMING BUTTON (SAFEMANSYSTEM OPTION)

- See the chapter "DESCRIPTION AND USE OF OPTIONS" page 2-62.

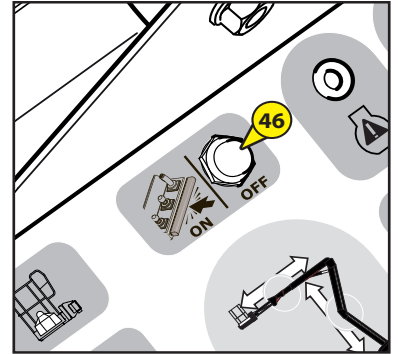

47 - SENSITIVE EDGE (SAFEMANSYSTEM OPTION)

- See the chapter "DESCRIPTION AND USE OF OPTIONS" page 2-62.

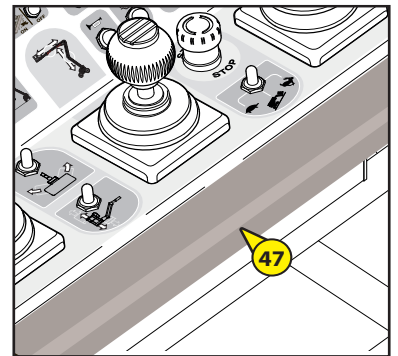

48 - BLUE WARNING LIGHT (SAFEMANSYSTEM OPTION)

- See the chapter "DESCRIPTION AND USE OF OPTIONS" page 2-62.



SCREEN DISPLAY - DESCRIPTION OF THE PAGES

1 - PRESENTATION PAGE

1 PRESENTATION PAGE :

- When you switch on, an initialisation page appears briefly on the screen and then the pre-heating page is displayed.

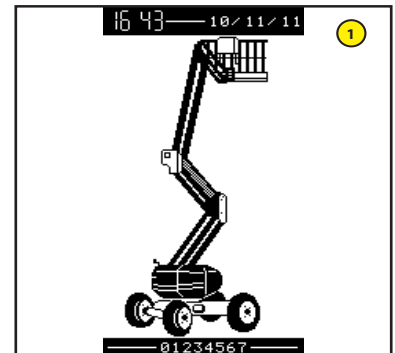

2 - PRE-HEATING PAGES

2 PRE-HEATING PAGES :

- The Pre-heating page is displayed for the whole of the adjustable pre-heating period and the bar graph increases in increments in proportion to the pre-heating time elapsed.

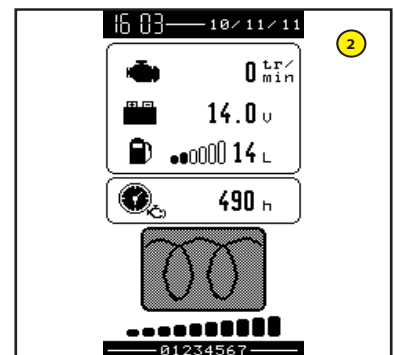

3 START-UP PAGE :

- When the pre-heating time has expired (bar graph complete), 'OK' is displayed, followed by the Work page or, where applicable, the Fault page.

A: Network search

B: Start-up OK

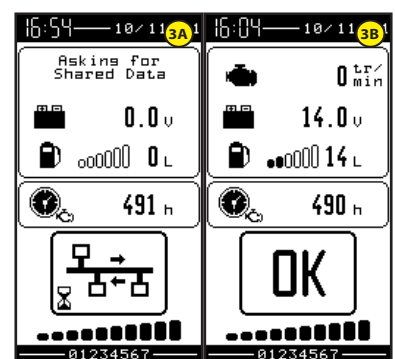

3 - WORK PAGES

4 WORKING PAGE FROM THE BASE WITH FAULT PRESENT

5 WORKING PAGE FROM THE BASE WITH ENGINE OIL PRESSURE FAULT PRESENT

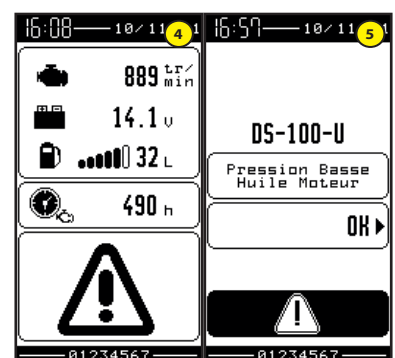







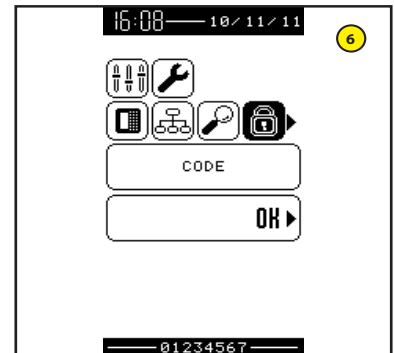

4 - MENU DISPLAY

6 DISPLAY THE MENU:

- After switching power on, press on  to display the page of proposed menus and select the chosen menu using the arrows   arrows then validate with .



7 TO MODIFY A SUB-MENU:

- After having chosen the menu, select the various choices of modifications, if required, using the arrows  .
- Use the buttons   to change the value of the selected option, then validate for a first time using  to display the parameter-modification confirmation message, then press again to validate. To return to the previous page, press on .

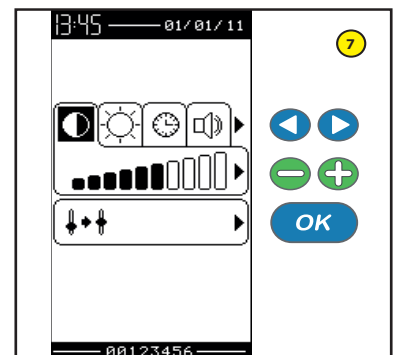



DESCRIPTION OF THE SUB-MENUS

Icons	Menu	Sub-menu	Parameters	User		Dealers / Renters			
				Visu	Maintenance	Visu	Maintenance		
	Access codes			Without		****			
	Screen settings	Screen setting: Contrast, Brightness.			X		X		
		Date, time, screen beep deactivation			X		X		
	Coding	View program and equipment codes.		X		X			
		View history of Machine N° per module.				X			
	Diagnostic	1 - Engine hour counters	Hire counter	X			X		
			Engine hour counter	X		X			
		2 - Daily hours, engine running.		X		X			
		3 - View inputs / outputs		X		X			
		4 - Fault history	View Fault history	X		X			
	Parameters	User options	Translation and movement beep options (movements).		X		X		
			Optional rotating flashing light on switch-on.		X		X		
		Dealer options	Telescope locking					X	
			Prohibition on forward movement during Work mode					X	
			Prohibition on basket tilting during Work mode					X	
			Activation of wheel realignment					X	
			Safe Man System Activation					X	
		Manufacturer options	Encoded anti-starting				X		
		Languages > French, English, German, Dutch only					X		
		System parameters	Engine management						X
			Lower arms						X
			Upper arm						X
			Telescope						X
			Telescope end stop						X
			Pendular arm						X
Turret rotation							X		
Basket tilt							X		
Basket rotation							X		
Steering control							X		
Maintenance intervals						X			
	Maintenance	Maintenance	View of next expected maintenance operations	X		X			
			Confirmation of maintenance performed				X		
		Maintenance History	View of maintenances performed				X		



Icons	Menu	Sub-menu	Parameters	User		Dealers / Renters		
				Visu	Maintenance	Visu	Maintenance	
Display of the "CALIBRATION" icon after entry of a code.								
	Calibrations	1 – Engine rpm calibration					X	
		2 – Joystick calibration					X	
		3 - Speed calibration	Max raising speed for lower arms					X
			Max lowering speed for lower arms					X
			Max raising speed for upper arm					X
			Max lowering speed for upper arm					X
			Max telescope extension speed					X
			Max telescope retraction speed					X
			Max pendular arm raising speed					X
			Max pendular arm lowering speed					X
			Max basket tilt extension speed					X
			Max basket tilt retraction speed					X
			Max turret right rotation speed					X
			Max turret left rotation speed					X
			Max basket right rotation speed					X
			Max basket left rotation speed					X
		Max forward translation speed in Work mode				X		
		Max reverse translation speed in Work mode				X		
		4 - Overload calibration						X
		5 - Generator calibration						X
6 - Parameter management	Restore machine parameters					X		
	Save machine parameters					X		
	Return to pre-set factory values					X		

USING THE LIFTING PLATFORM

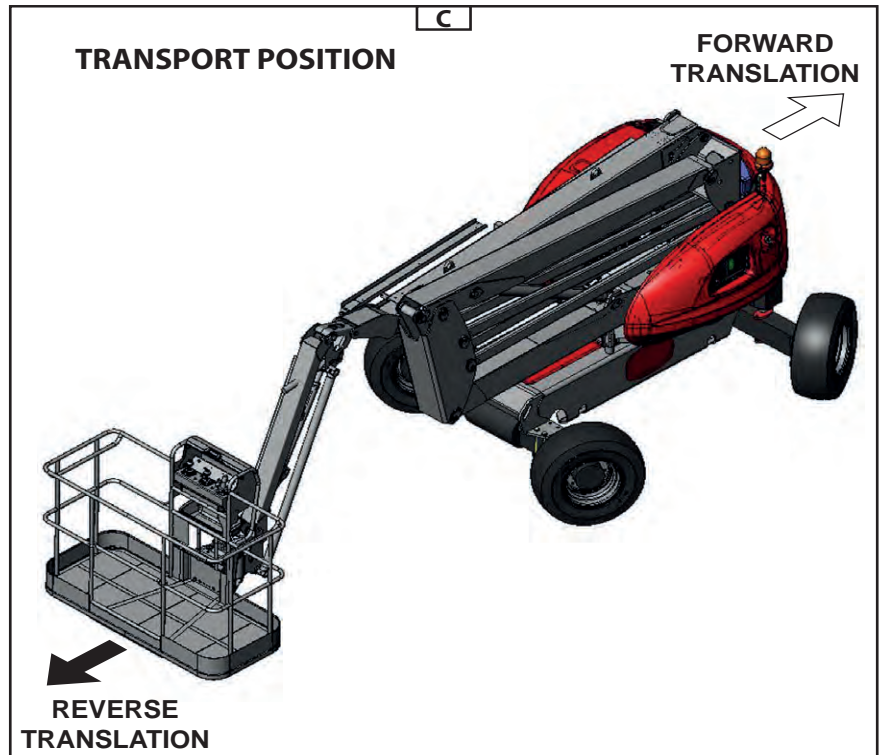
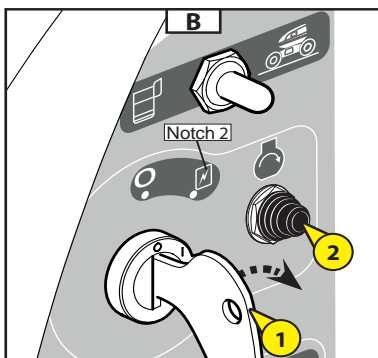
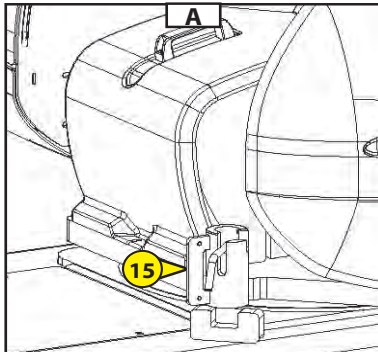

BEFORE STARTING THE LIFTING PLATFORM

- Check the following levels:

- Engine oil.
- Oil in the hydraulic reservoir.
- Coolant.

STARTING THE LIFTING PLATFORM

- Turn the ignition key 1 to notch 2 to make the electrical contact (Fig. B).
- Press button 2 to start up the IC engine (Fig. B).



Do not operate the starter for more than 30 seconds and run a pre-heating cycle between all failed attempts to start.

- Release the button as soon as the engine starts and let the engine run at tickover speed.



Never try to push or pull the lifting platform to start it. Such an action would cause severe damage to the transmission.



MOVEMENT IN TRANSPORT / WORK MODE

- Before moving or using the machine, remove the turret lock Rep. 15 (see Fig. A).
- The lifting platform has two separate movement modes: Transport mode (Fig. D) and Work mode (Fig. E) (direction of forward movement (Fig. C)).
- Transport mode: the lifting platform's arms are in the Low position and the telescope is retracted; the pendular arm may be raised completely. This mode enables you to move at high speed and operate beyond the tilt limit of the machine (See the CHARACTERISTICS section) (Fig. D).
- **Work mode** : one or more of the lifting platform's arms are raised and/or the telescope is extended. In this mode, translations are made at slow speed and the safety systems for tilt and overload are active (Fig. E).

NB: You must use Ramp speed (full power with the speed restricted to 2 km/h) to cross over steep slopes or move over very broken ground. This can prove very useful, for instance, if an access ramp must be borrowed to move the lifting platform onto a truck bed.



In Work mode, any movement over broken ground, loose surfaces, slopes greater than the authorised level of tilt (see the CHARACTERISTICS section) likely to overturn or unbalance the lifting platform is PROHIBITED.



The turret must be in the lifting platform's axis when making a translation in Hare mode.



Before driving the lifting platform, ensure that the turret is correctly oriented with respect to the chassis, i.e. in the translation direction (black and white arrows).



In the case of a steep slope: - no load in the basket;

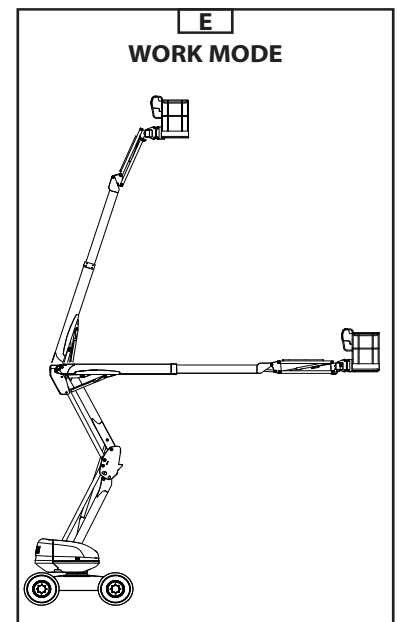
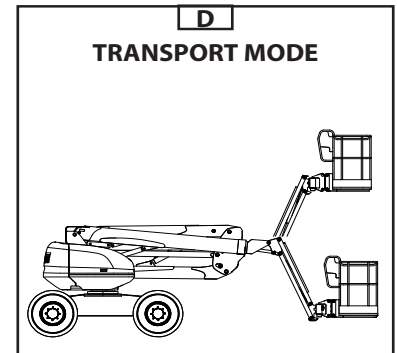



INSTALLATION ON THE WORK SITE AND LIFTING

- The lifting platform has been designed to work on a flat, horizontal surface; it is important to clear the space in which the lifting platform will be working.
- Bring the lifting platform to the work site.
- If necessary, load the equipment to be carried (stack so as not to inconvenience the operator and prevent anything falling).
- Climb into the lifting platform.



Wearing a safety helmet and a harness is compulsory.

- Press the "Dead Man's" pedal and start to manoeuvre to position yourself in the work area.

NB: When the lifting platform is free of the chassis, translation switches automatically to slow speed.
Only the pendular arm can be raised completely while maintaining Transport speed.



When manoeuvring the lifting platform (lifting, rotation...), look around and above you. Pay particular attention to the electric cables and any items that may be in the lifting platform's operating space.



Familiarise yourself with the instruments on the ground maintenance and emergency station and in the basket, described in the previous pages and in particular the warnings specifying the risks involved in performing certain manoeuvres.

SAFETY SYSTEMS

- When the lifting platform is overloaded, the buzzer sounds continuously and all movements are blocked.
 - Solution : unburden the basket.

LOWERING

- When the work is complete: retract the telescope and lower the arms to bring the lifting platform back to Transport position.



Pay attention to the people on the ground when you are descending.

STOPPING THE LIFTING PLATFORM

- When the lifting platform is not being used, cut off the electrical power supply by setting the ignition key to the Neutral position (see 1 – Ignition).



LOADING / UNLOADING THE LIFTING PLATFORM



Check that the safety instructions relating to the truck bed have been correctly applied before loading the lifting platform and ensure that the transport vehicle's driver is aware of the lifting platform's dimensional characteristics and its weight (see the CHARACTERISTICS section).

- When loading the lifting platform on to a truck bed, the platform must be in Transport position:

- Counterweight facing the ramp (counterweight above the lifting platform's steering wheels) (see 1 – Safety instructions and advice in the SAFETY STICKERS section, Ref Nos. 1 and 2).
- Upper arm on its stop
- Lower and intermediate arm in the Low position
- Telescope retracted
- It is possible to raise the pendular arm so that it does not touch the ground but it is inadvisable to make a translation movement with the basket raised excessively; keep the basket in the lowest possible position during manoeuvres (danger of objects falling or impacts; see 1 - Safety Instructions and Advice; Driving Instructions section).
- Block the lifting platform's turret from rotating by using the pin 1 (Fig. A (see the CONTROL INSTRUMENTS section, paragraph: BLOCKING TURRET ROTATION)
- Use "Ramp" speed

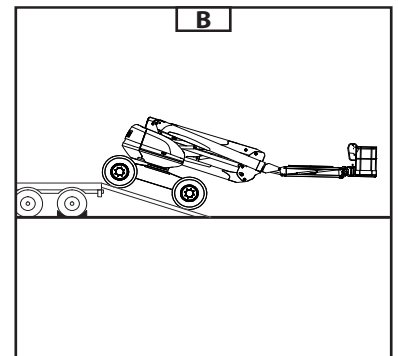
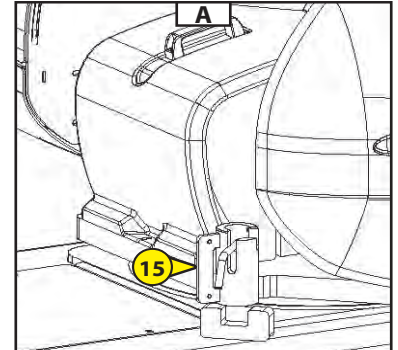

Ensure that the truck bed is large enough and has a sufficient load capacity to transport the lifting platform. Also check the truck bed's permissible ground contact pressure with regard to the lifting platform.



There is a risk of the lifting platform losing adherence (sliding or slipping) when going up or down the loading ramps, when these are wet, muddy or damp. It is therefore necessary to ensure the platform's stability with a winch attached to the lash-down points on the machine.

LOADING

- Fix the loading ramps to the truck bed so as to have the smallest angle possible for loading the machine (Fig. B).
- Chock the truck bed's wheels 1 (Fig. C).



Please adapt the lifting platform's translation speed by controlling it with the translation joystick.

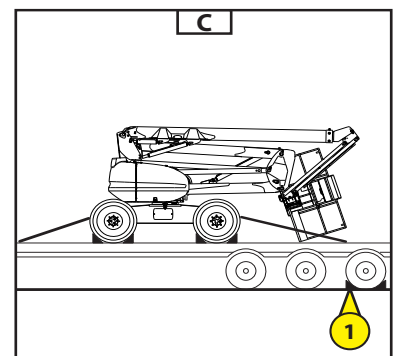

PROCEDURE FOR FOLDING THE LIFTING PLATFORM

- Rotate the basket to the left on its stop.
- Raise the upper arm.
- Initiate the basket tilt movement to fold the basket under the upper arm.
- Lower the upper arm, paying attention not to hit the basket on the ground.
- Initiate the basket tilt movement again to fold the basket to the maximum under the upper arm (Fig. C).



LASHING DOWN THE LIFTING PLATFORM

- Set chocks on the truck bed on each of the lifting platform's tyres, front and rear 2 (Fig. E).
- Also set chocks on the truck bed on the inside and the outside of each tyre 3 (Fig. D).
- Lash the lifting platform down on the truck bed with sufficiently strong ropes 4 (Fig. E), to the front and the rear, passing the ropes through the slinging eyes 5 (Figs. D and F).

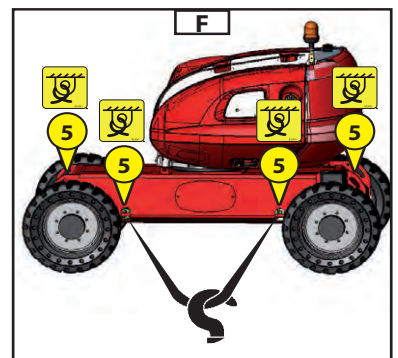
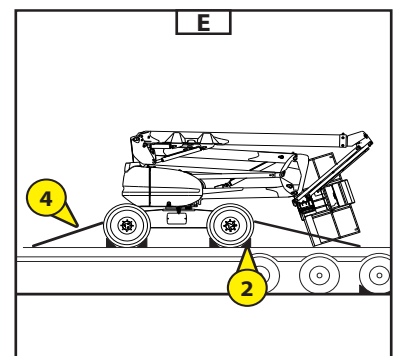
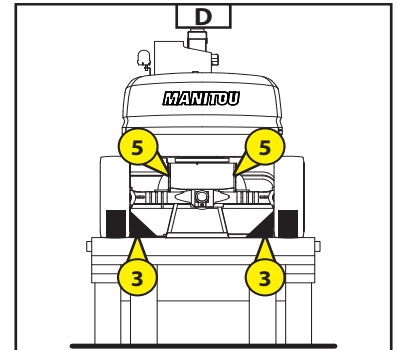

RESCUE PROCEDURE

- This paragraph describes the procedures to follow, the controls to use in the event of a problem (breakdown of the lifting platform or someone trapped in the basket) while the lifting platform is working.
- When taking over the machine and regularly afterwards, the details of this procedure must be read and fully understood by the operator and everyone whose duties are centred on activities in contact with the machine.

IN THE EVENT OF THE OPERATOR FALLING ILL – PRIORITY SYSTEM

- In the case where the user is taken ill or finds themselves unable to manoeuvre, the person on the ground can take control of the nacelle from the backup and maintenance control panel.
- Follow the instructions below.
- Switch the contactor 1 (Fig. A) to Position A and hold it down to recover control of the platform's movements.
- Proceed to lower the platform using the base controls.

- FROM THE LIFTING PLATFORM NO. 951 458 AND THE LIFTING PLATFORM NO. 950 552

- In the case where the user accidentally triggers the basket emergency stop, the person on the ground can take control of the nacelle from the backup and maintenance control panel.
- Follow the instructions below.
- Switch the contactor 1 (Fig. A) to Position A and hold it down to recover control of the platform's movements.
- Restart the engine 2 (Fig. A).
- Proceed to lower the platform using the base controls.



Pay attention to any constructions or objects that may be under the lifting platform.

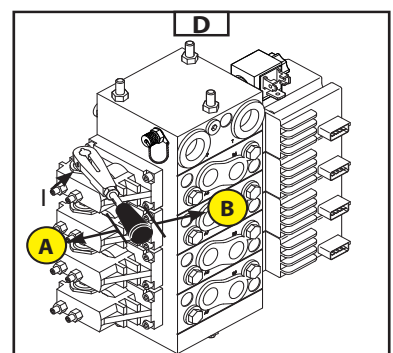
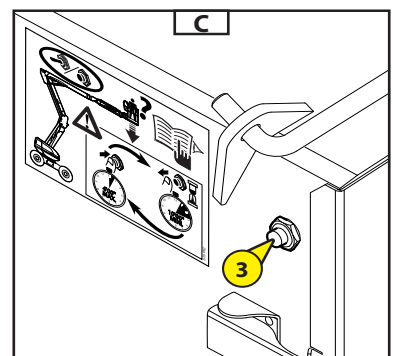
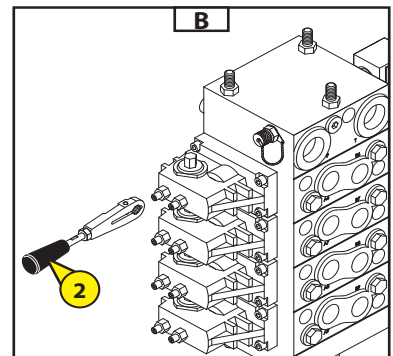
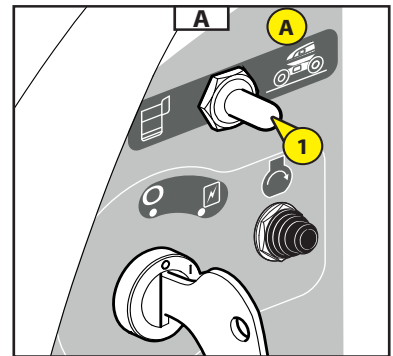

IN THE EVENT OF AN ACCIDENT OR MACHINE BREAKDOWN – EMERGENCY SYSTEM

ELECTRICAL BREAKDOWN

- When an accident occurs or a breakdown makes the electrical control boxes unusable, the machine is provided with systems for manually performing all the lifting platform's movements.
- Lift the turret's right-hand cover.
- Grasp the control lever 2 (Fig. B) and position it on one of the elements to perform the desired movement (Figs. D-E-F-G).



During these operations the system does not control:
- The Tilt safety system.
- The Basket Overload safety system.

- **To raise and lower the lower arms** (set the lever to I).
- Press button 3 (Fig. C) to activate the emergency pump and, at the same time, push the lever (Fig. D) to:
 - A - to lower the lower arms
 - B - to raise the lower arms

To extend and retract the telescope (set the lever to II).

- Press button 3 (Fig. C) to power the distributor and, at the same time, pull the lever (Fig. E) to:

- A - to retract the telescope
- B - to extend the telescope

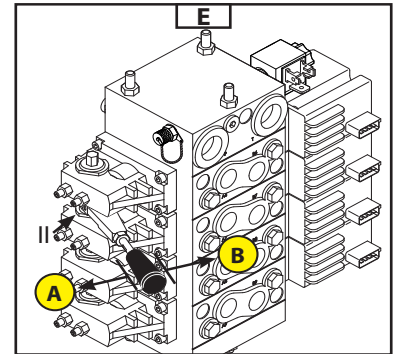

To raise and lower the upper arm (set the lever to III).

- Press button 3 (Fig. C) to power the distributor and, at the same time, push the lever (Fig. F) to:

- A - to lower the upper arm
- B - to raise the upper arm

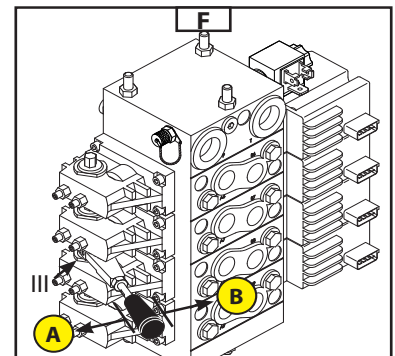

Rescue procedure on the main distributor:

For turret right rotation (set the lever to IV).

- Turn the wheel on valve 4 (Fig. H) clockwise. 

- Press button 3 (Fig. C) to power the distributor and, at the same time, pull the lever (Fig. G) to B.

- Turn the wheel on valve 4 (Fig. H) anti-clockwise. 

For turret left rotation (set the lever to IV).

- Turn the wheel on valve 5 (Fig. H) clockwise. 

- Press button 3 (Fig. C) to power the distributor and, at the same time, pull the lever (Fig. G) to B.

- Turn the wheel on valve 5 (Fig. H) anti-clockwise. 

To raise the pendular arm (set the lever to IV).

- Turn the wheel on valve 6 (Fig. H) clockwise 

- Press button 3 (Fig. C) to power the distributor and, at the same time, pull the lever (Fig. G) to B.

- Turn the wheel on valve 6 (Fig. H) anti-clockwise. 

To lower the pendular arm (set the lever to IV).

- Turn the wheel on valve 7 (Fig. H) clockwise 

- Press button 3 (Fig. C) to power the distributor and, at the same time, pull the lever (Fig. G) to B.

- Turn the wheel on valve 7 (Fig. H) anti-clockwise. 

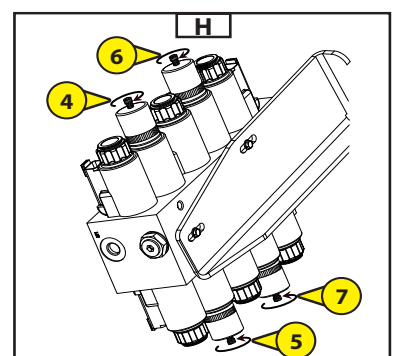
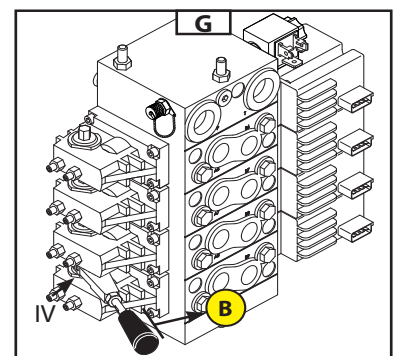



REPAIRING A BREAKDOWN FROM THE BASKET

- Press button 40 (Fig. J) to activate the emergency pump and, at the same time, use the basket controls.
- (See the CONTROL INSTRUMENTS section B - LIFTING PLATFORM CONTROL STATION



Only to be used to bring the basket down to the ground in the event of the engine breaking down

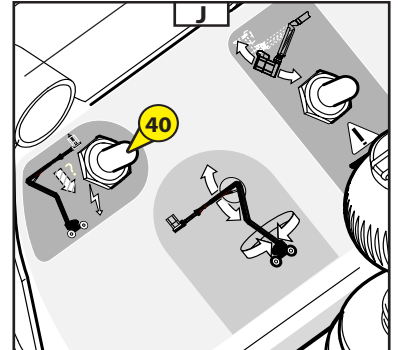

**PROPORTIONAL
DISTRIBUTOR**

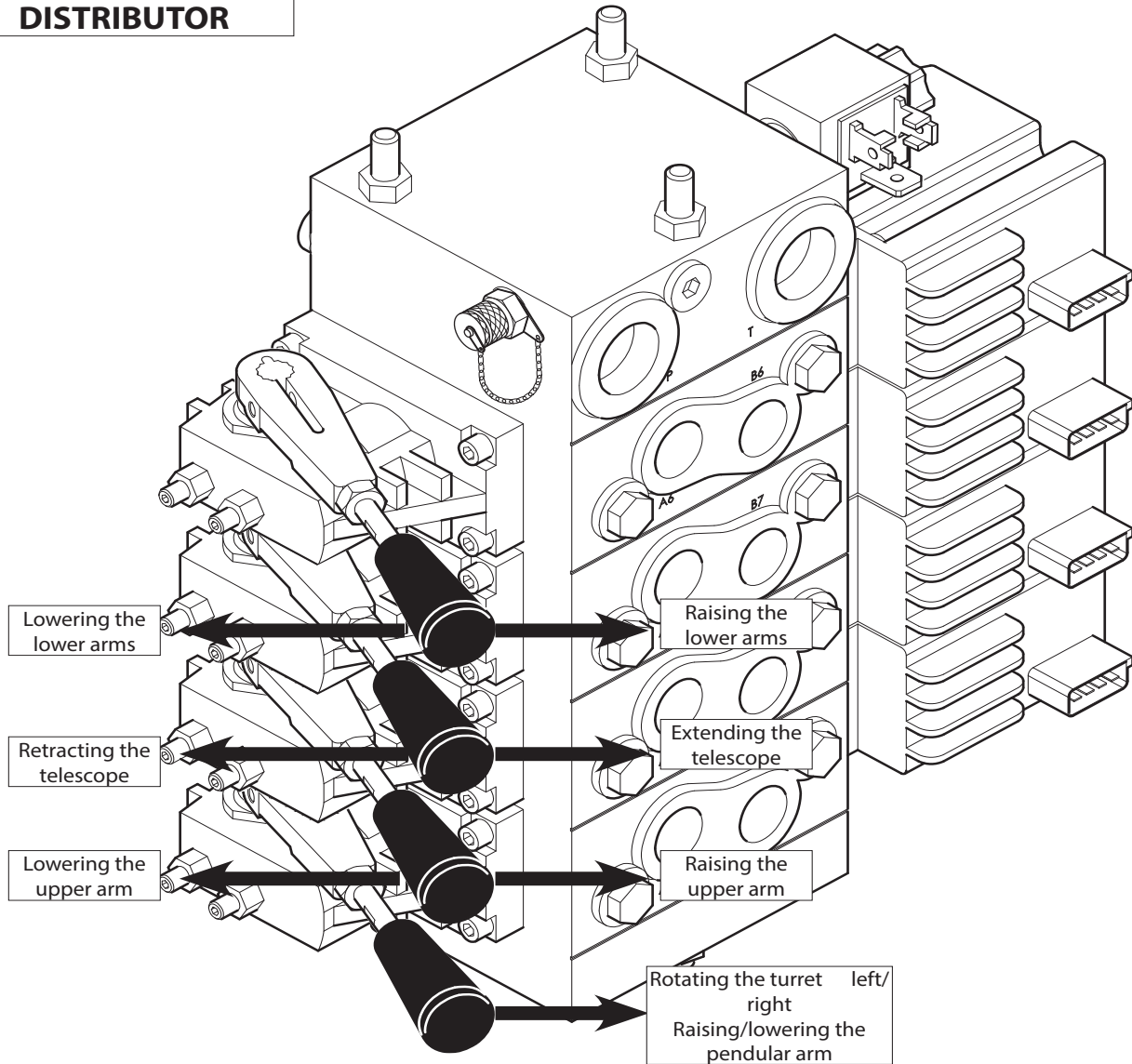

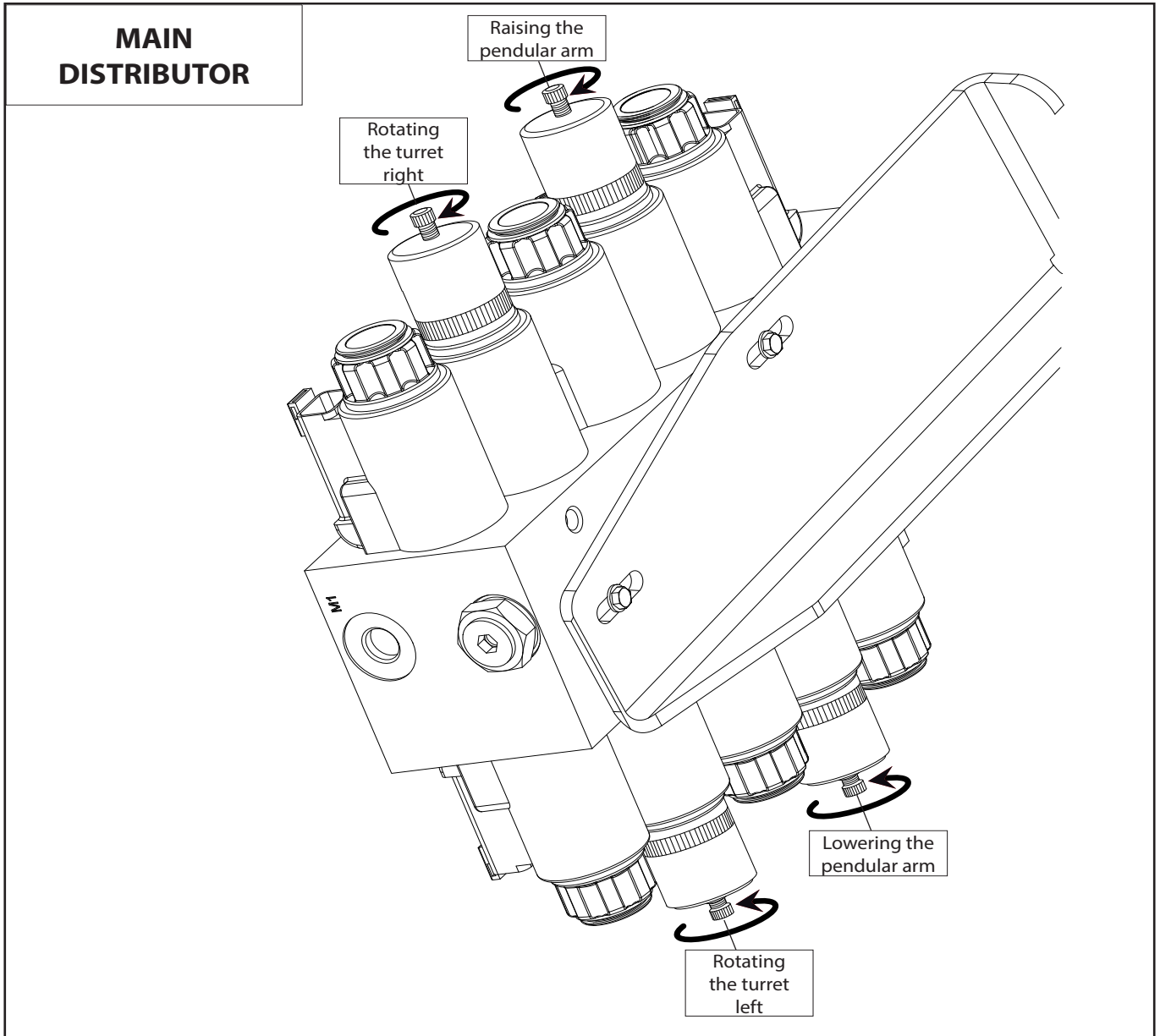

DESCRIPTION AND USE OF THE OPTIONS

GENERATOR OPTION

Precautions for use for the operator when using lifting platforms fitted with this option:

 Do not connect electrical equipment that is not fitted with a shut-off switch. Voltage spikes may occur when starting the generator.

- ON: Use the switch on the basket console to activate the generator.
- OFF: Press the button to activate or deactivate the generator
- The generator stops temporarily during a hydraulic movement (e.g.: an arm movement).

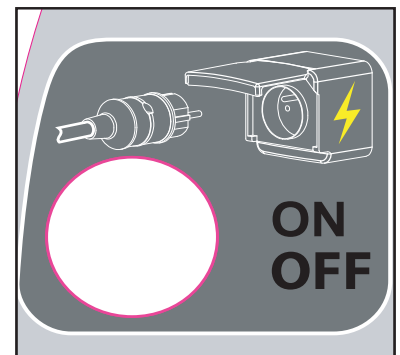
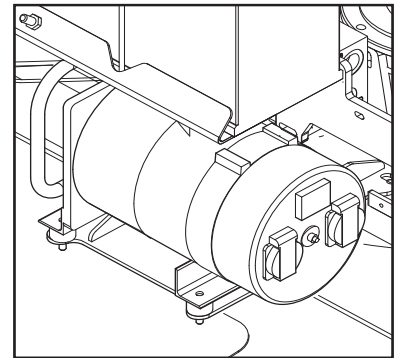

UNSTEERED REAR AXLE OPTION

- This option enables the steered wheels on the front axle (P2) to operate while the rear axle wheels are fixed.

 The "crab" (P1) and "4-wheel drive" (P3) functions are not active. Indicator lights 28A and 28B are not active.

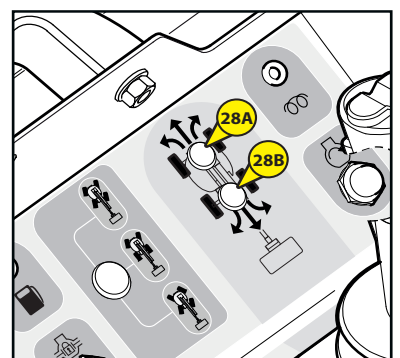
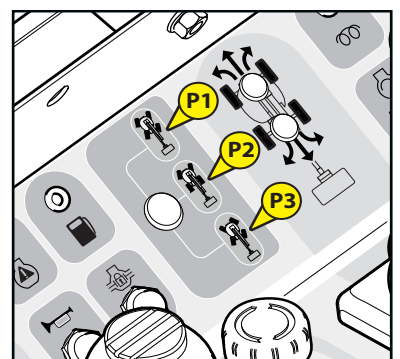



18" WHEELS OPTION

- This option is recommended for use on very difficult terrain.



The use of the 18" wheels option requires modification of the translation speeds by adjustment of certain programming parameters.



The empty weight of the nacelle changes with the use of 18" wheels. The manufacturer's data plate must be replaced to show the new empty weight (see CHARACTERISTICS section).



The height of the nacelle changes with the use of 18" wheels (see CHARACTERISTICS section).

SAFE MAN SYSTEM

The safe man system option is a system used to disable all of the basket control panel controls when activated by the nacelle user.

OPERATION

- Each time the nacelle is switched on, a system test is performed: there is a beep and the blue warning light flashes (Fig. C).
- If the pressure-sensitive edge is pressed (Fig. A), the system cuts all of the nacelle controls. The blue warning light and an audible alarm are activated.
- If the user releases the pressure-sensitive edge:
By pressing the nacelle "OFF" rearming button (Fig. B) once, the user can regain control of the nacelle controls. The blue warning light and the audible alarm are turned off.
- If the user continues to press on the pressure-sensitive edge:
By pressing the nacelle "OFF" rearming button (Fig. B) once, the user can regain control of the nacelle controls. The blue warning light and the audible alarm are turned off when the user releases the pressure-sensitive edge.

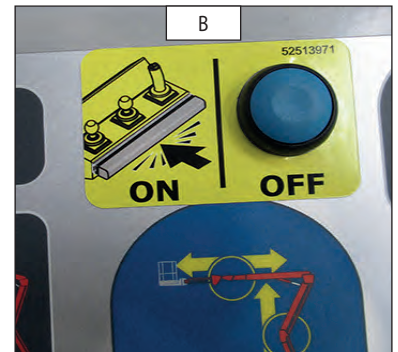
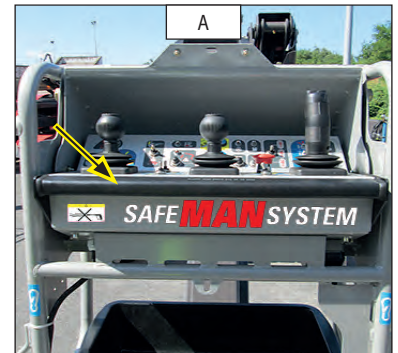





3 - MAINTENANCE





CONTENTS

<u>MANITOU SPARE PARTS AND ORIGINAL EQUIPMENT</u>	<u>3-4</u>
<u>CHECKLIST FOR SWITCHING ON</u>	<u>3-5</u>
<u>FILTER ELEMENTS AND BELTS</u>	<u>3-6</u>
<u>SAFETY ELEMENTS</u>	<u>3-7</u>
<u>LUBRICANTS AND FUEL</u>	<u>3-8</u>
<u>MAINTENANCE TABLE FOR THE 160 ATJ E3 -160 ATJS E3 - 180 ATJ 2 E3</u>	<u>3-10</u>
<u>A – EVERYDAY OR EVERY TEN OPERATING HOURS</u>	<u>3-12</u>
<u>B – EVERY 50 OPERATING HOURS</u>	<u>3-15</u>
<u>C – EVERY 250 OPERATING HOURS</u>	<u>3-20</u>
<u>D – EVERY 500 OPERATING HOURS</u>	<u>3-28</u>
<u>E – EVERY 1000 OPERATING HOURS</u>	<u>3-34</u>
<u>F – EVERY 2000 OPERATING HOURS</u>	<u>3-38</u>
<u>G – OCCASIONAL MAINTENANCE</u>	<u>3-40</u>



MANITOU ORIGINAL EQUIPMENT AND REPLACEMENT PARTS

OUR PERSONNEL LIFTING PLATFORMS MUST ONLY BE SERVICED USING MANITOU ORIGINAL PARTS.

BY AUTHORISING THE USE OF MANITOU NON-ORIGINAL PARTS,

YOU RISK

- From a legal viewpoint, becoming liable in the event of an accident.
- From a technical viewpoint, causing operating breakdowns or reducing the lifting platform's operating life.

THE USE OF COUNTERFEIT PARTS OR COMPONENTS NOT APPROVED BY THE MANUFACTURER,
RESCINDS THE BENEFITS ACCRUING FROM THE CONTRACTUAL WARRANTY.

BY USING MANITOU ORIGINAL PARTS IN YOUR SERVICING OPERATIONS,

**YOU BENEFIT
FROM KNOW-HOW**

Through its network, MANITOU provides the operator with,

- Know-how and competence.
- Guarantee of the quality of the work performed.
- Original replacement parts.
- Help with preventive maintenance.
- Efficient diagnostic assistance.
- Improvements based on feedback from experience.
- Training of the operating personnel.
- Only the Manitou network knows the lifting platform's design in detail and therefore has the best technical capabilities to provide for its maintenance.

ORIGINAL REPLACEMENT PARTS ARE ONLY DISTRIBUTED BY MANITOU
AND ITS DEALER NETWORK.

The list of dealers in the network is available on the MANITOU site www.manitou.com



COMMISSIONING CHECK LIST

0 = Good 1 = Missing 2 = Incorrect



100	IC ENGINE	
01	Air filter	
02	Fuel tank	
03	Fuel lines - Filter	
04	Injection or carburettor system	
05	Radiator and cooling system	
06	Belts	
07	Hoses	
101	TRANSMISSION	
01	Reversing system	
02	Gearbox control	
03	Cut-off pedal	
04	Clutch	
102	AXLES / TRANSFER BOX	
01	Function and sealing	
02	Endstop adjustment	
103	HYDRAULIC / HYDROSTATIC CIRCUIT	
01	Tank	
02	Pumps and attachments	
03	Tightness of the connections	
04	Lifting cylinder(s)	
05	Tilting cylinder(s)	
06	Accessory cylinder(s)	
07	Telescope cylinder(s)	
08	Compensation cylinder(s)	
09	Steering cylinder(s)	
10	Distributor	
11	Balancing valve	
104	BRAKING CIRCUIT	
01	Operation of the service and parking brake	
02	Brake fluid level	
105	LUBRICATION AND GREASING	
106	JIB / MANISCOPIC / MANIACCES ASSEMBLY	
01	Beam and telescope(s)	
02	Skid	
03	Joints	
04	Protective plate	
05	Forks	
107	MAST ASSEMBLY	
01	Fixed and mobile uprights	
02	Protective plate	
03	Chains	
04	Pulleys	
05	Forks	

108	ACCESSORIES	
01	Adaptations to the machine	
02	Hydraulic connections	
109	CAB / PROTECTOR / ELECTRICAL CIRCUIT	
01	Seat	
02	Dashboard and radio	
03	Buzzer and alarm light / safety system	
04	Heating / Air conditioning	
05	Windscreen wiper / Windscreen washer	
06	Operating warning	
07	Reversing warning	
08	Road lights	
09	Additional lights	
10	Flashing light	
11	Battery	
110	WHEEL	
01	Rims	
02	Tyres / Pressure	
111	NUTS AND BOLTS	
112	CHASSIS AND BODYWORK	
113	PAINTWORK	
114	GENERAL OPERATION	
115	INSTRUCTIONS MANUAL	
116	CUSTOMER'S INSTRUCTIONS	



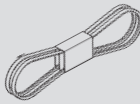
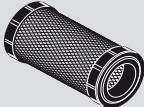
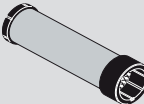
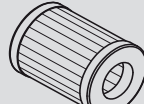

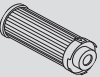
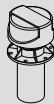

FILTER ELEMENTS AND BELTS

IC ENGINE	
 <p>IC ENGINE OIL FILTER Reference: 894022 Replace: 500 H</p>	 <p>FAN BELT Reference: 895489 Replace: 500 H</p>
 <p>DRY AIR FILTER CARTRIDGE Reference: 227959 Clean: 50 H Replace: 500 H</p>	
 <p>DRY AIR FILTER SAFETY CARTRIDGE Reference: 227960 Replace: 1000 H*</p>	
 <p>FUEL FILTER CARTRIDGE Reference: 781909 Replace: 500 H</p>	
<p>*: This interval is provided only as an indication (see: 3 - MAINTENANCE: MAINTENACE TABLE) for cleaning and replacing this.</p>	

HYDRAULIC SYSTEM	
 <p>HYDROSTATIC TRANSMISSION OIL FILTER CARTRIDGE Reference : 518251 Replace : 500 H</p>	 <p>HYDROSTATIC OIL RESERVOIR SUCTION STRAINER Reference : 749589 Clean : 1000 H</p>
 <p>AUXILIARY HYDRAULIC OIL FILTER CARTRIDGE Reference : 518251 Replace : 500 H</p>	 <p>HYDRAULIC RESERVOIR FILLING STRAINER Reference : 794879</p>

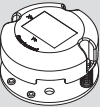
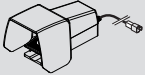

SAFETY COMPONENTS

ELECTRICAL COMPONENTS			
	TILT SENSOR Reference : 52521690		DEAD MAN'S PEDAL Reference : 831136
	OVERLOAD SENSOR Reference : 676845		LOW ARM SENSOR Reference : 833194
	TELESCOPE SENSOR Reference : 832955		



LUBRICANTS AND FUEL



USE THE RECOMMENDED LUBRICANTS AND FUEL:

- Oils may not be mixed when topping up
- MANITOU oils are perfectly suitable for easy draining.

OIL DIAGNOSTIC ANALYSIS

If you set up a maintenance or servicing contract with the dealer, a diagnostic analysis of the engine and axle oils may be requested, depending on the usage level.

(*) CHARACTERISTICS OF THE RECOMMENDED FUEL

- Use a quality fuel to obtain optimum performance from the engine.
- Type of Diesel fuel N590 - Auto/C0/C1/C2/C3/C4
- BS2869 Class A2
- ASTM D975-91 Class 2-2DA, US DF1, US DF2, US DFA
- JIS K2204 (1992) Grades 1, 2, 3 and Special Grade 3.

IC ENGINE				
COMPONENTS TO BE LUBRICATED	CAPACITY	RECOMMENDATION	PACKAGING	REFERENCE
IC ENGINE	6,7 Litres	MANITOU SAE 15W/40 engine oil	5 l	661706
			20 l	582357
			55 l	582358
			209 l	582359
			1000 l	490205
COOLANT	5 Litres	Cooling circuit (protection - 25°)	2 l	554002
			5 l	788246
			20 l	788247
FUEL TANK	52 Litres	Diesel (*)		

TRANSMISSION			
COMPONENTS TO BE LUBRICATED	RECOMMENDATION	PACKAGING	REFERENCE
TRANSFER BOX	TRACTELF axle oil SF3	5 l	545 976
		20 l	582 391
		209 l	894 257
TRANSMISSION UNIVERSAL JOINT	MANITOU BLUE multi-purpose oil	400 g	161589
		1 kg	720683
		5 kg	554974
		20 kg	499233
		50 kg	489670

HYDRAULIC SYSTEM				
COMPONENTS TO BE LUBRICATED	CAPACITY	RECOMMENDATION	PACKAGING	REFERENCE
HYDRAULIC OIL RESERVOIR	54 Litres	MANITOU Hydraulic ISO VG 46 oil	5 l	545500
			20 l	582297
			55 l	546108
			209 l	546109



LIFTING STRUCTURE				
COMPONENTS TO BE LUBRICATED	CAPACITY	RECOMMENDATION	PACKAGING	REFERENCE
GENERAL LUBRICATION		MANITOU high-performance grease	Cartridge 400 g	479330
TURRET CROWN GEAR BEARING RACEWAYS LUBRICATION				
TURRET CROWN GEAR TEETH LUBRICATION		SHELL MALLEUS GL 205 oil	Aerosol	744802
BRAKE REDUCER ON THE TURRET'S REDUCTION GEAR	0,85 Litres	MANITOU SAE80W90 axle / gearbox mechanical transmission oil SAE80W90	2 l 20 l 55 l 220 l	499237 546330 546221 546220

FRONT AXLE				
COMPONENTS TO BE LUBRICATED	CAPACITY	RECOMMENDATION	PACKAGING	REFERENCE
FRONT AXLE DIFFERENTIAL	8 Litres	Axle oil TRACTELF SF3	5 l 20 l 209 l 1000 l	545976 582391 894257 720149
FRONT WHEEL REDUCER	0,6 Litre	Oil SHELL SPIRAX A 90	20 l 209 l	661950 662000

REAR AXLE				
COMPONENTS TO BE LUBRICATED	CAPACITY	RECOMMENDATION	PACKAGING	REFERENCE
REAR AXLE DIFFERENTIAL	8 Litres	Axle oil TRACTELF SF3	5 l 20 l 209 l 1000 l	545976 582391 894257 720149
REAR WHEEL REDUCER	0,6 Litre	Oil SHELL SPIRAX A 90	20 l 209 l	661950 662000



MAINTENANCE TABLE 160 ATJ E3 - 160 ATJ S E3 - 180 ATJ 2 E3

(1): COMPULSORY OVERHAUL AFTER 500 HOURS or 6 MONTHS

This overhaul must compulsorily be performed after approximately the first 500 hours of operation or 6 months after the machine is put into service (when the earlier of the two periods is reached).

(2): The internal-combustion engine oil and its oil filter must be replaced after the first 50 hours of operation, and subsequently every 500 hours of operation.

A = REGULATE, C = CHECK, G = GREASE, N = CLEAN,
P = BLEED, R = REPLACE, V = DRAIN

	PAGE	 (1)	DAILY OR EVERY 10 HOURS OF OPERATION	EVERY 50 HOURS OF OPERATION	EVERY 250 HOURS OF OPERATION	EVERY 500 HOURS OF OPERATION OR 6 MONTHS	EVERY 1000 HOURS OF OPERATION OR 1 YEAR	EVERY 2000 HOURS OF OPERATION OR 2 YEARS	EVERY 40000 HOURS OF OPERATION	OCCASIONAL
IC ENGINE										
Engine oil level	3-13/3-33	C	C	<<<	<<<	<<<	<<<	<<<	<<<	
Coolant level	3-13/3-38	C	C	<<<	<<<	<<<	<<<	V/R	<<<	
Fuel level	3-13	C	C	<<<	<<<	<<<	<<<	<<<	<<<	
Fuel circuit hose	3-15/3-40			C	<<<	<<<	<<<	<<<	<<<	P
Radiator core	3-18	N		N	<<<	<<<	<<<	<<<	<<<	
Dry air filter cartridge	3-19/3-28	R		N	<<<	R	<<<	<<<	<<<	
Alternator/crankshaft/fan belt tension	3-18/3-27/3-32	C/A			C/A	R	<<<	<<<	<<<	
Cooling circuit	3-25	C			C	<<<	<<<	<<<	<<<	
Fuel filter	3-26	N			N	R	<<<	<<<	<<<	
Fuel filter cartridge (2)	3-19/3-28	R			N	R	<<<	<<<	<<<	
Engine oil (2)	3-13/3-33	V				V	<<<	<<<	<<<	
Engine oil filter (2)	3-33	R				R	<<<	<<<	<<<	
Fuel tank	3-34						V/N	<<<	<<<	
Dry air filter safety cartridge	3-34						R	<<<	<<<	
Engine silentblocks	3-37						C**	<<<	<<<	
Engine speeds	3-37						C**	<<<	<<<	
Valve sets	3-39	C**					C**	<<<	<<<	
Injectors	3-39							C	<<<	
Radiator	3-39							C**	<<<	
Water pump and thermostat	3-39							C**	<<<	
Alternator and starter	3-39							C**	<<<	
Fuel injection pressure	3-39							C**	<<<	
Turbocompressor	3-39							C**	<<<	
Injection pump	3-39							C**	<<<	
TRANSMISSION										
Brakes	3-12/3-32	C	C	<<<	<<<	C	<<<	<<<	<<<	
Axles	3-16/3-17	G		G	<<<	<<<	<<<	<<<	G/C**	
Tightness of the universal joint bolts	3-31	C			C	<<<	<<<	<<<	<<<	
Hydrostatic transmission circuit pressure	3-37						C**	<<<	<<<	
Start of hydrostatic transmission control	3-37						C/A*	<<<	<<<	
TYRES										
Condition of the wheels and tyres	3-14	C	C	<<<	<<<	<<<	<<<	<<<	<<<	
Tightness of the wheel nuts	3-22				C**	<<<	<<<	<<<	<<<	
Wheels	3-41									R
LIFTING STRUCTURE										
Telescope adjustment	3-22				C	<<<	<<<	<<<	<<<	
Brake reducer on the turret reduction gear	3-23/3-31				C	V/R	<<<	<<<	<<<	
Tightness of the bolts on the turret rotation motor	3-30					C	<<<	<<<	<<<	
HYDRAULIC SYSTEM										
Hydraulic oil	3-14/3-30	C	C	<<<	<<<	V/R	<<<	<<<	<<<	
Hydrostatic transmission oil filter cartridge	3-29	R				R	<<<	<<<	<<<	
Auxiliary oil filter cartridge	3-29					R	<<<	<<<	<<<	
Condition of the hoses	3-30					C**	<<<	<<<	<<<	
Hydraulic circuit strainer	3-37						N	<<<	<<<	
Hydraulic movement speeds	3-37						C**	<<<	<<<	
Condition of the cylinders (leaks, rods)	3-37						C**	<<<	<<<	
Hydraulic oil reservoir	3-39							N	<<<	
Hydraulic circuit pressures	3-39							C**	<<<	
Hydraulic circuit flows	3-39							C**	<<<	



A = REGULATE, C = CHECK, G = GREASE, N = CLEAN,
P = BLEED, R = REPLACE, V = DRAIN

	PAGE	 (1)	DAILY OR EVERY 10 HOURS OF OPERATION	EVERY 50 HOURS OF OPERATION	EVERY 250 HOURS OF OPERATION	EVERY 500 HOURS OF OPERATION OR 6 MONTHS	EVERY 1000 HOURS OF OPERATION OR 1 YEAR	EVERY 2000 HOURS OF OPERATION OR 2 YEARS	EVERY 40000 HOURS OF OPERATION	OCCASIONAL
ELECTRICITY										
Condition of the joystick bellows	3-14		C	<<<	<<<	<<<	<<<	<<<	<<<	
Level of electrolyte in the battery	3-15	C		C	<<<	<<<	<<<	<<<	<<<	
Emergency pump	3-22	C			C	<<<	<<<	<<<	<<<	
Arm position sensors	3-25	C			C	<<<	<<<	<<<	<<<	
Tilt sensor	3-25	C			C	<<<	<<<	<<<	<<<	
Overload sensors	3-25	C			C	<<<	<<<	<<<	<<<	
Density of the electrolyte in the battery	3-31	C			C	<<<	<<<	<<<	<<<	
Condition of the cable bundles and the cables themselves	3-37						C**	<<<	<<<	
FRONT AND REAR AXLE										
Front and rear axle differential oil	3-20/3-35	C			C	<<<	V/R	<<<	<<<	
Front and rear axle oil	3-20/3-35	C			C	<<<	V/R	<<<	<<<	
Front and rear wheel reducer oil	3-20/3-35	C			C	<<<	V/R	<<<	<<<	
CHASSIS										
Turret orientation crown	3-23	G			G	<<<	<<<	<<<	<<<	
Shafts	3-24				G	<<<	<<<	<<<	<<<	
Tightness of the bolts fixing the axle assemblies on the chassis	3-25	C			C	<<<	<<<	<<<	<<<	
Tightness of the turret orientation crown bolts	3-32	C				C	<<<	<<<	<<<	
LIFTING PLATFORM										
General inspection	3-12	C	<<<	<<<	<<<	<<<	<<<	<<<	<<<	
Functional checks	3-12	C	<<<	<<<	<<<	<<<	<<<	<<<	<<<	
Lifting platform stickers	3-26				C	<<<	<<<	<<<	<<<	
Overload	3-27				C	<<<	<<<	<<<	<<<	
Stopping distance	3-27				C	<<<	<<<	<<<	<<<	
Fitting slings on the lifting platform	3-42									XXX
Setting in Freewheeling mode	3-45									XXX
Transporting the lifting platform on a truck bed	3-45									XXX
Maintenance stand	3-47									XXX
OPTION										
SafeManSystem	3-14	C	<<<	<<<	<<<	<<<	<<<	<<<	<<<	

(*): Every 10 hours for the first 50 hours and then a final time after 250 hours.

(**): Contact your dealer.



A - DAILY OR EVERY 10 HOURS OF OPERATION

A1 - GENERAL INSPECTION

CHECK

- Scrupulously inspect the machine and check that there are no cracked welds, corrosion or structural damage, loose or missing nuts and bolts, hydraulic leaks, damaged control cables or loose electrical connections."

A2 - FUNCTIONAL CHECKS

CHECK



Any malfunction of the platform must be detected every day before putting it into service. Identify any malfunction and take the platform out of service if any malfunction is detected.

Choose a testing area on a sturdy level unencumbered surface.

When manoeuvring the platform (raising, rotation...), look all around and above you. Pay particular attention to any electrical cables or other objects that may be in the platform's operating area.

EMERGENCY STOP

- Press the emergency stop buttons on the controls on the ground.
 - > Result: the engine must stop and no functions must be active.
- Pull the red emergency stop button into the operating position and re-start the engine.
- Perform the test with the basket emergency stop button to obtain the same result.

DEAD MAN DEVICE FUNCTIONS

- Without pressing the elevation-validation button known as the "dead man device", select an access-platform function.
 - > Result: the access platform should not elevate.
- Press the elevation-validation button known as the "dead man device" and select an access-platform function.
 - > Result: the access platform should elevate.

Carry out of this test on the functions of elevation, lowering, turret rotation and translation from the base and basket control panels to obtain the same results.

BUZZER

- Press the basket's warning button
 - > Result: the buzzer should sound.

ELEVATION/LOWERING FUNCTIONS

- From the base control panel, select all of the elevation then lowering functions (arms 1/2/3 and jib).
 - > Result: the access platform should raise then lower.
- From the basket control panel, select all of the elevation functions (arms 1/2/3 and jib).
 - > Result: the access platform should raise then lower.

STEERING

- Note: when testing the functions of steering and translation, stay in the access platform, turning yourself in the direction in which the machine is moving.
- From the basket control panel, select the steering control.
 - > Result: the steering wheels should turn in the controlled direction.

TRANSLATION AND BRAKING

- Select a translation control
 - > Result: the machine should move in the direction indicated by the white arrow for forward movement and the black arrow for backward movement, then stop when the control is released.

TRANSLATION SPEEDS IN WORKING MODE

- Carry out lifting with one or more access-platform arms and/or extend the telescope.
- Perform a translation movement.
 - > Result to be obtained: the translation must be carried out at working speed.



TILT SENSOR

For this operation, open out the arms.

- Place the access platform in a leaning position greater than that authorised.
- > Result to be obtained: the movements of telescope extension and arm lifting must be locked.
- The leaning indicator is lit in the basket, and the buzzer is active intermittently in the basket.

OVERLOAD SENSOR

For this operation, fold the arms into the transport position.

- Place a weight greater than that indicated in the basket.
- > Result: the movements of telescope extension and arm lifting must be locked. The overload indicator is lit in the basket and the buzzer is continuously active in the basket.

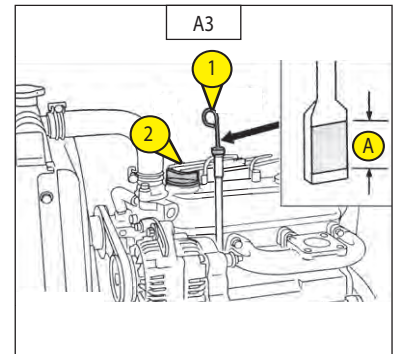

A3 - IC ENGINE OIL LEVEL

CHECK

Set the lifting platform on a horizontal surface with the engine switched off and let the oil drain back into the sump.

- Open the left-hand cover
- Remove the dipstick 1 (Fig. A3).
- Wipe the dipstick and check that the oil level is between the two upper notches. Ref. A (Fig. A3).
- If necessary, add oil (see the LUBRICANTS section) via the filling hole 2 (Fig.A3).

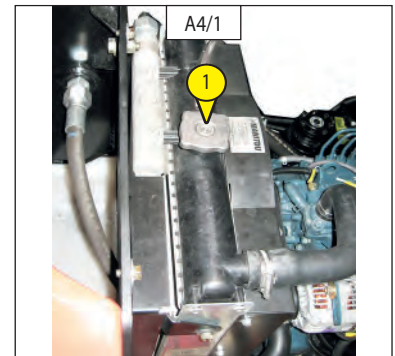

A4 - COOLANT LEVEL

CHECK

Set the platform on a horizontal surface with the engine off and wait for the engine to cool down.

- Open the left-hand cover.
- Remove the radiator cap 1 (Fig. A4/1)
- Check that the coolant level is up to the supply opening.
- Check the drain tap 2 (Fig. A4/2) located on the side of the engine casing.

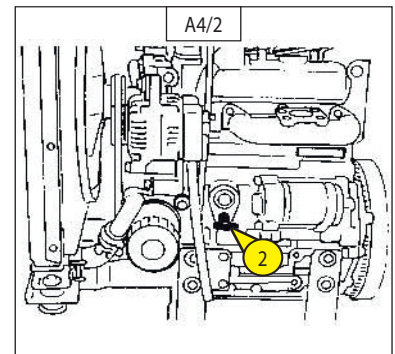

If the radiator cap must be removed, follow the above precautions and then retighten it securely. Use pure fresh water and an antifreeze solution to refill the emergency reservoir.

If a water leak occurs, contact your dealer

Ensure that muddy water or sea water does not get into the radiator.

Do not refill the emergency reservoir with coolant above the 'FULL' marking.

Take care to tighten the cap firmly. If the cap is loose or badly closed, water can escape and the engine can overheat.



Do not remove the radiator cap when the engine is hot. Then, gently loosen the cap up to the stop to release any excessive pressure before removing the cap completely. If the engine overheats, steam may spurt from the radiator or the emergency reservoir, possibly causing severe burns.

A5 - FUEL LEVEL

CHECK

Keep the fuel tank as full as possible to reduce any condensation due to atmospheric conditions as much as possible.

- Remove the cap 1 (Fig. A5)
- Top up the tank via the filling hole with clean Diesel, filtered through a strainer or a clean, lint-free cloth.

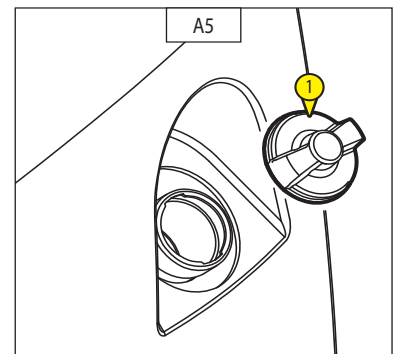

Do not smoke or bring a naked flame near to the tank during filling or when the tank is open. Never fill the tank with the engine running.



The fuel tank is vented by the filling cap. When changing the cap, always use an original cap with the vent hole.

A6 - HYDRAULIC OIL LEVEL

CHECK

- Set the lifting platform on a horizontal surface in Transport position with the engine switched off.
- The oil level should be in the middle of indicator 1 + or - 10 mm (Fig. A6/1).
- If necessary, add oil (see the LUBRICANTS section) via the filling hole 2 (Fig. A6/2).



There may be an oil difference of between 10 and 20 mm between hot and cold oil. It is advisable to top up the oil when the oil is hot.

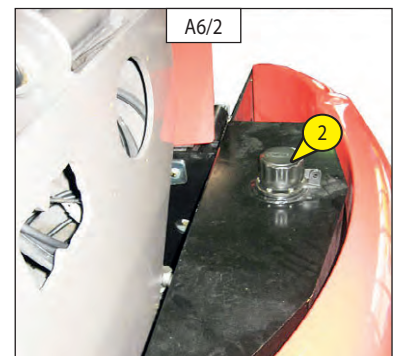
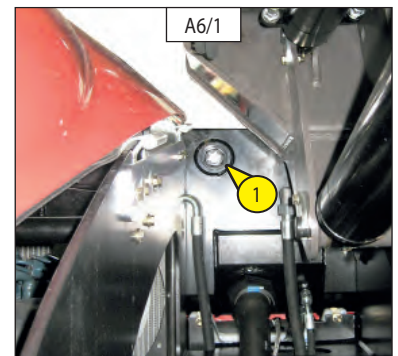

A7 - CONDITION OF THE JOYSTICK BELLOWS

CHECK

For this operation, climb into the basket when the engine is switched off.

- Check that the joystick's rubber bellows 1 (Fig. A7) are in good condition by operating them as if you are making a movement.
- The bellows should not show any cracking or fissures: risk of water penetration, which could impair the machine's operation.

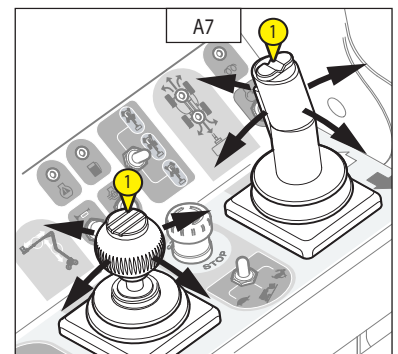

A8 - CONDITION OF THE TYRES & WHEELS

CHECK

- Check the condition of the tyres to discover any cuts, tears or swollen or worn patches, etc. on the tyres.



A8 - SAFE MAN SYSTEM (OPTION) STATUS

CHECK

Press on the pressure-sensitive edge (Fig. A8/1) and confirm:

- > All nacelle movements stop.
- > The blue warning light and the audible alarm operate.
- > The operation of the nacelle movements when the "OFF" button is pressed once (Fig.8/2).

If the pressure-sensitive edge is defective, the blue warning light flashes faster and a special alarm sounds. However, the machine can be operated normally.

If the "OFF" rearming button does not work, use the emergency stop to rearm the nacelle.



In the case of malfunction off the option, consult your dealer.

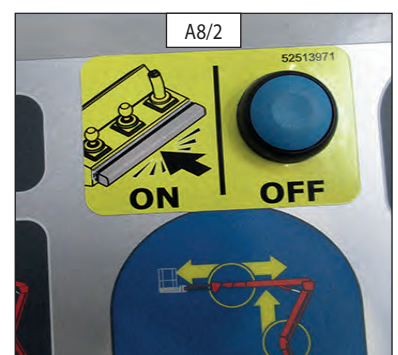

B - TOUTES LES 50 HEURES DE MARCHÉ

Perform the operations described above as well as the following operations.

B1 - LEVEL OF BATTERY ELECTROLYTE

CHECK

Check the electrolyte level in each battery.
If the ambient temperature is high, check the level more often than every 50 hours of operation.

- Remove the battery cover Ref. 1 (Fig. B1/1).
- Remove the battery clamp Ref. 2 (Fig. B1/2).
- Free both the caps over the elements 3 (Fig. B1/3).
- The level must be 1cm above the battery plates.
- If necessary, top up with clean distilled water kept in a glass container.
- Clean and dry the two caps 3 (Fig. B1/2) and refit them.
- Check the battery terminals and apply some Vaseline to prevent them from oxidising.
- Re-install the battery clamp 2 (Fig. B1/2).
- Refit the battery cover.
- Refit the two nuts on the battery cover.

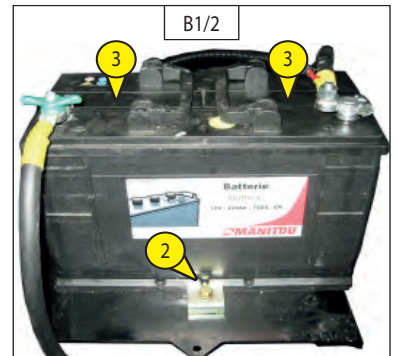
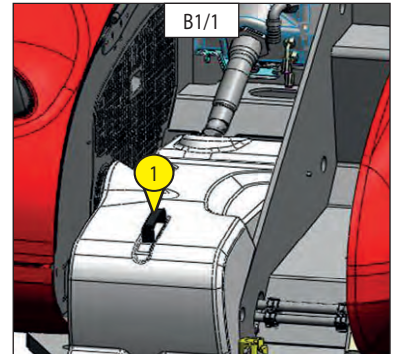

Manipulating and servicing a battery can be dangerous; take the following precautions:



- **Wear protective goggles.**
- **Keep the battery horizontal when manipulating it.**
- **Never smoke or work close to a naked flame.**
- **Work in a sufficiently well-ventilated area.**
- **If some electrolyte splashes onto your skin or in your eyes, rinse the affected area thoroughly with cold water for 15 minutes and call a doctor.**

B2 - FUEL CIRCUIT HOSE

CHECK

Set the lifting platform on a horizontal surface, with the engine switched off, and wait for the engine to cool down.



Check the condition of the fuel circuit hoses after switching off the engine. If the fuel supply hoses are damaged, this can cause a fire.

- Open the bonnet.
- Visually check the condition of the fuel circuit supply hoses (Fig. B2/1 and B2/2) and the tightening collars. If these are damaged, replace them immediately (replace all the fuel supply hoses and the tightening collars at least every two years).

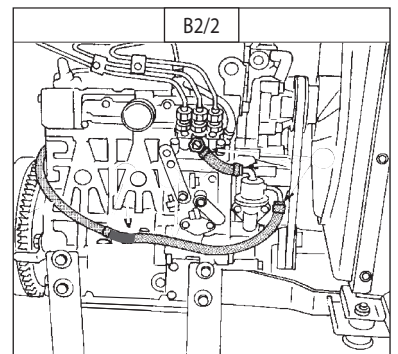
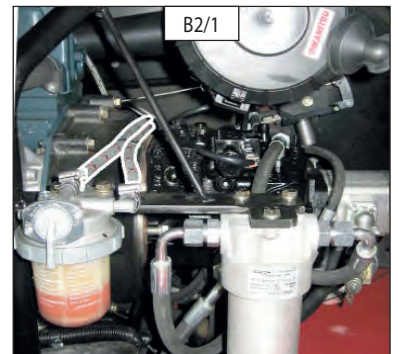

B3 - AXLES

GREASE

- Grease the front and rear wheel reducer pivots 1 (Figs. B3/1, B3/3 and B3/4) and 2 (Figs. B3/2, B3/3 and B3/4) (8 grease nipples).

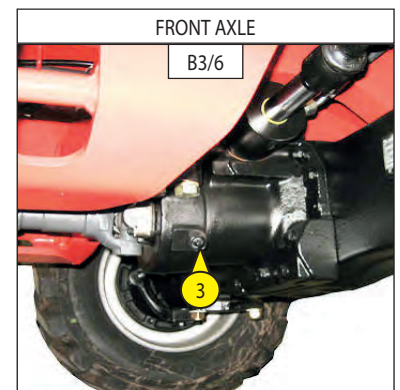
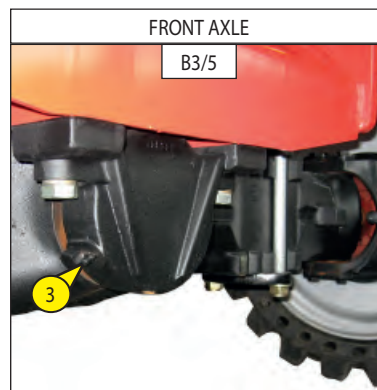
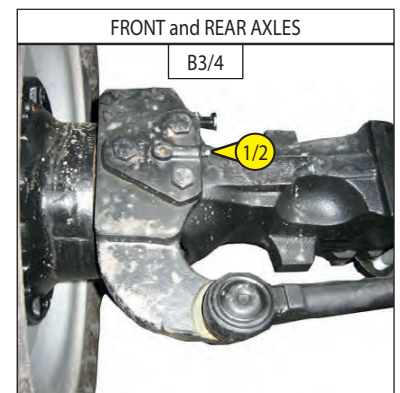
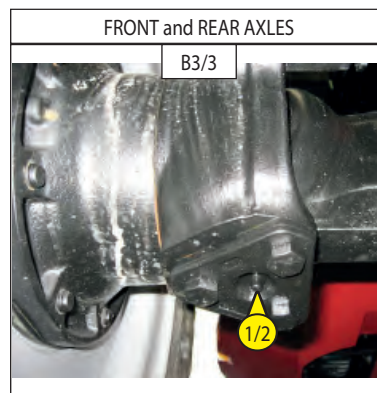
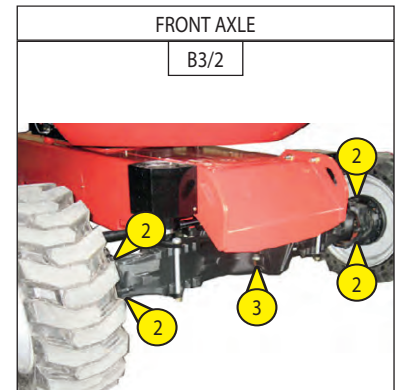
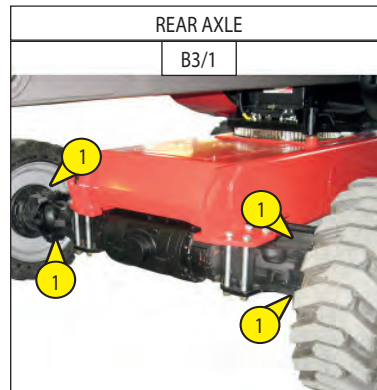

- Grease the front axle's oscillation shaft 3 (Figs. B3/2, B3/5 and B3/6) (2 grease nipples).

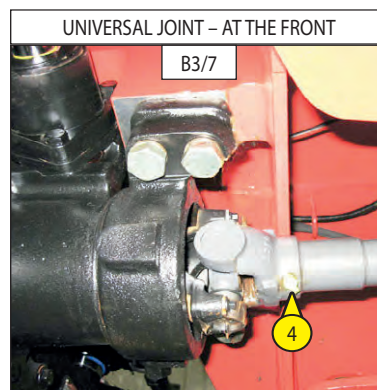

- Grease the transmission's universal joint at the front 4 (Fig. B3/7).

B3 - AXLES (160 ATJ S EURO 3)

GREASE

- Grease the front and rear wheel reducer pivots 4 (Fig. B3/8) and 5 (Fig. B3/9) (8 grease nipples)

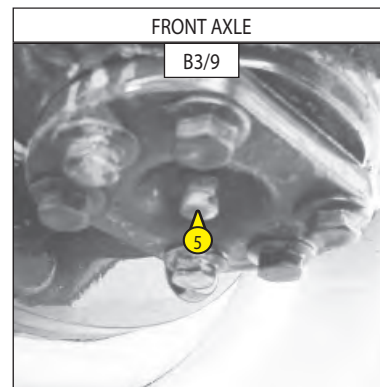
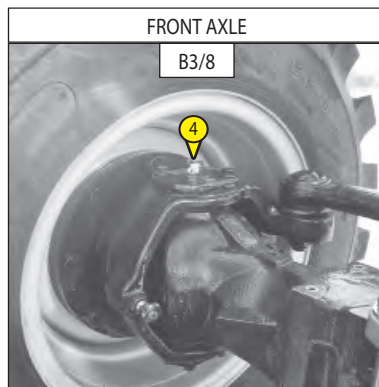

B4 - ALTERNATOR/CRANKSHAFT/FAN BELT TENSION

ADJUST

- Open the left-hand cowl.
- Check the condition of the belt for any signs of wear or cracking and replace it, if necessary (see: 3 - MAINTENANCE: FILTER ELEMENTS AND BELTS).
- Check the tension between the crankcase and alternator pulleys.
- Under thumb pressure (98 N), the tension Ref. A (Fig. B4/1) must be 7 to 9 mm (Fig. B4/1).
- Adjust, if necessary.
- Loosen the bolts 1 (Fig. B4/2) two or three turns.
- Swivel the alternator assembly to obtain the requisite belt tension.
- Retighten the bolts 1 (fig. B4/2).



When changing an alternator belt, recheck the tension after the first 20 hours of operation.

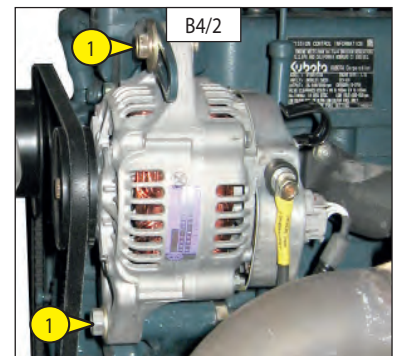
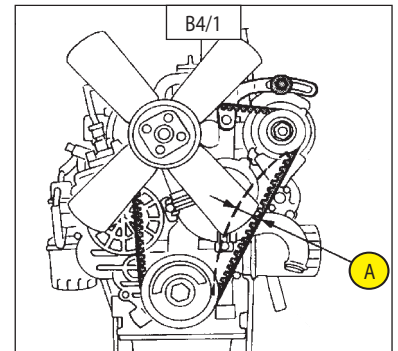

B5 - RADIATOR CORE

CLEAN

- Open the bonnet.
- To avoid clogging the radiator core, clean it with a jet of compressed air directed from the front towards the back (Fig. B5). This is the only way to expel any dirt effectively.



Clean the radiator core daily when the lifting platform is being used in a very dusty area.

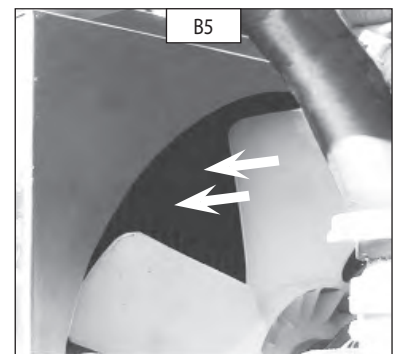

B6 - DRY AIR FILTER CARTRIDGE

CLEAN

If the machine is being used in a very dusty atmosphere, reduce these maintenance intervals and see the FILTER ELEMENTS AND BELTS section.

- Open the left-hand cover.
- Locate the air filter 1 (Fig. B6/1).
- Unclip the cover 2 (Fig. B6/2).
- Release the filter cartridge 3 (Fig. B6/3) by pulling it.
- Leave the safety filter 4 (Fig. B6/4) in place.
- Use a jet of compressed air to clean the filter cartridge, blowing only from the inside towards the outside.



Observe the safety distance of 30 mm between the jet of air and the cartridge to avoid tearing or piercing the cartridge. You must not blow out the cartridge near the air filter casing. Never clean the cartridge by tapping it against a hard surface. Protect your eyes during this operation.

- Clean the inside of the filter with a clean, damp, lint-free cloth.
- Check the condition of the filter cartridge and replace it, if necessary.
- Refit the cartridge and the cover.



Never wash a dry air filter cartridge. You must not clean the safety cartridge located inside the filter cartridge under any circumstances; replace it with a new one if it is clogged or damaged.

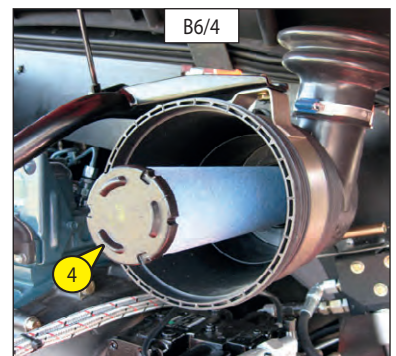
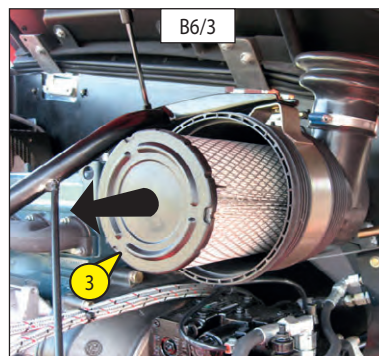
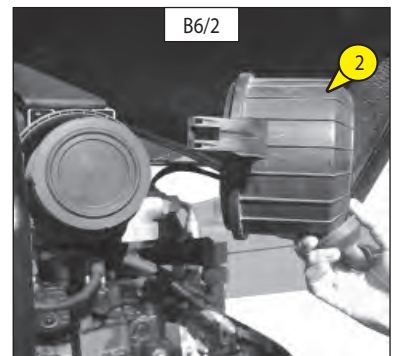
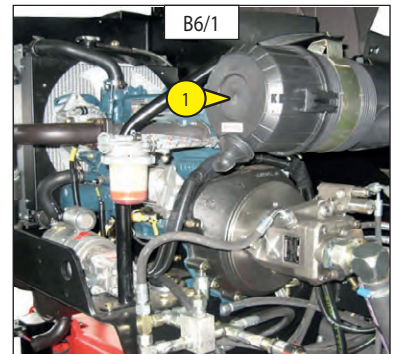

B7 - FUEL FILTER CARTRIDGE

REPLACE

- Open the left-hand cowl.
- Carefully clean the exterior of the filter and its holder to prevent dust from entering the system.
- Close the fuel tap 1 (Fig. B7/1) to the OFF position.
- Unscrew the retaining ring 2, remove the container 3 (Fig. B7/2) and clean the interior with a paintbrush impregnated with clean diesel.
- Throw away the filter cartridge 4 (Fig. B7/2).
- Reinstall the assembly with a new filter (see 3 – MAINTENANCE: FILTER ELEMENTS AND BELTS section).

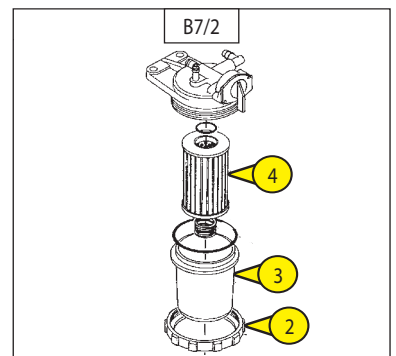
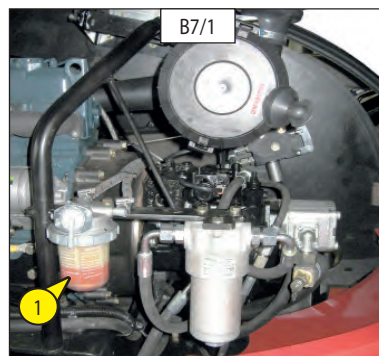

C - EVERY 250 OPERATING HOURS

C1 - DIFFERENTIAL OIL LEVEL

CHECK

For the 160 ATJ E3:

Set the lifting platform on a horizontal surface with the engine switched off.

- Remove the cap 1 (Fig. C1/1), the oil level should be flush with the hole.
- If necessary, top up the oil (See the LUBRICANTS section) via the filling hole 2 (Fig. C1/2).
- Refit and tighten the cap 1 (Fig. C1/1).

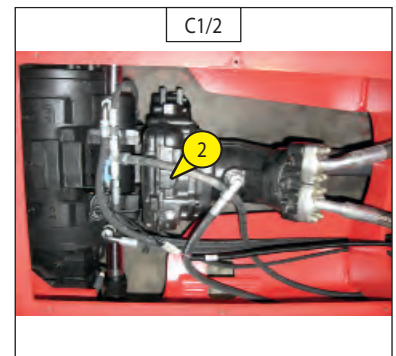
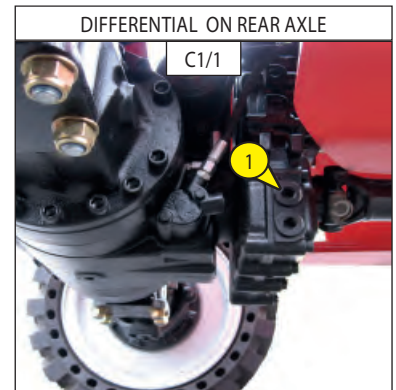

For the 160 ATJS E3:

Set the lifting platform on a horizontal surface with the engine switched off.

- Remove the cap 3 (Fig. C1/3), the oil level should be flush with the hole.
- If necessary, top up the oil (See the LUBRICANTS section) via this hole.
- Refit and tighten the cap 3 (Fig. C1/3) (tightening torque 6 daNm).

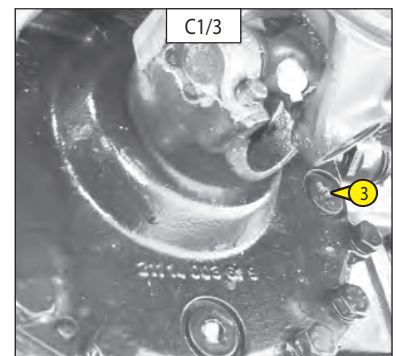

C2 - FRONT AND REAR AXLE OIL LEVEL

CHECK

For the 160 ATJ E3

Set the lifting platform on a horizontal surface with the engine switched off.

- Remove the level plug 2 (Fig. C2/1: front axle) (Fig. C2/2: rear axle), the oil level should be flush with the hole.
- If necessary, top up the oil (See the LUBRICANTS section) via this hole.
- Refit and tighten the level plug 2 (Fig. C2/1: front axle) (Fig. C2/2: rear axle).

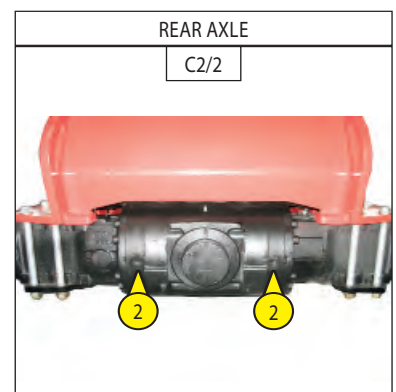
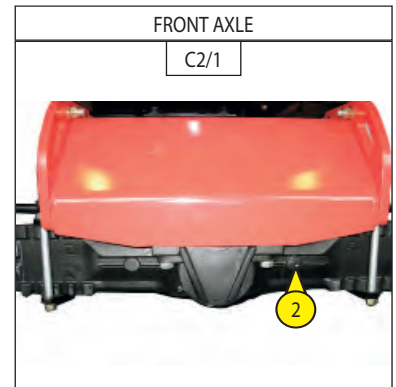

For the 160 ATJS E3:

- Remove the level plug 2 (Fig. C1/2: front axle) (Fig. C1/3: rear axle), the oil level should be flush with the hole.
- If necessary, top up the oil (See the LUBRICANTS section) via this hole.
- Refit and tighten the level plug 2 (Fig. C1/2: front axle) (Fig. C1/3: rear axle) (tightening torque 6 daNm)

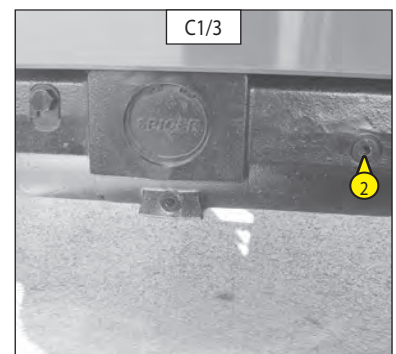
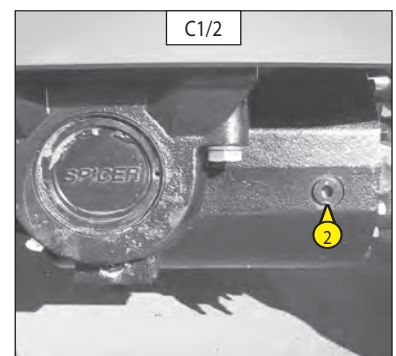

C3 - FRONT AND REAR WHEEL REDUCER OIL LEVEL

CHECK

Set the platform on a horizontal surface with the engine off.

- Check the oil level in each of the front and rear wheel reducers.
- Set the level plug 1 (Fig. C3) horizontal.
- Remove the level plug; the oil should be flush with the hole.
- Add oil, if necessary (see the LUBRICANTS section), via the same hole.
- Screw the plug back in tightly 1 (Fig. C3).
- Perform the same operation on each of the rear wheel reducers.

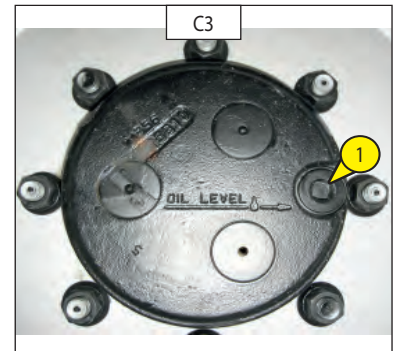

C4 - TIGHTENING THE WHEEL NUTS

CHECK

- Check the tightness of the wheel nuts (Fig. C4).



Failure to observe this instruction may cause the wheel pins to be damaged and break, as well as the wheels to deform.

C4 WHEEL NUT TIGHTENING TORQUE	
FRONT WHEELS	34 daN.m ± 15 %
REAR WHEELS	34 daN.m ± 15 %

C5 - EMERGENCY PUMP

CHECK

- Switch off the engine.

Check that the emergency pump is operating correctly by pressing the switch on the side of the base control box or the basket control box.

- Perform an arm lowering movement (example...)



You must not use the lifting platform under any circumstances if the pump is not working.

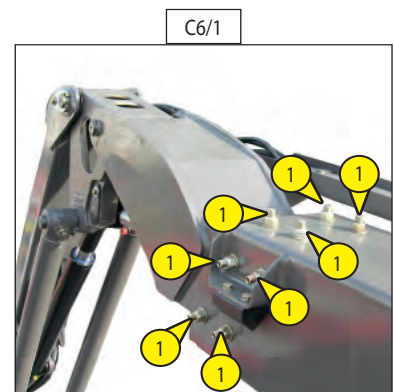

C6 - TELESCOPE ADJUSTMENT

CHECK

- Check the tightness of the 16 nuts on the telescope skids Ref.1 (Fig. C6/1 and C6/2).



Failure to observe this instruction may result in loss of the skids and damage to the telescope.

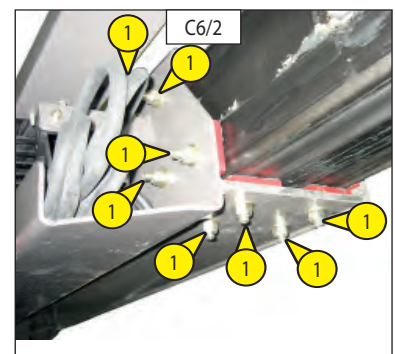

C7 - TURRET REDUCTION GEAR BRAKE REDUCER LEVEL

CHECK

Set the lifting platform on a horizontal surface, with the engine switched off.

- Remove the turret's internal cowl.
- The reduction gear is revealed with the valve block to the rear.
- Remove the sniffer-filling plug 1 (Fig. C7)
- The level is correct when the sniffer is full of oil.
- If necessary, top up the level with a syringe by filling the reducer via the sniffer-filler plug. The oil capacity is 1.3 litres.
- Refit the sniffer-filler plug 1 (Fig. C7).

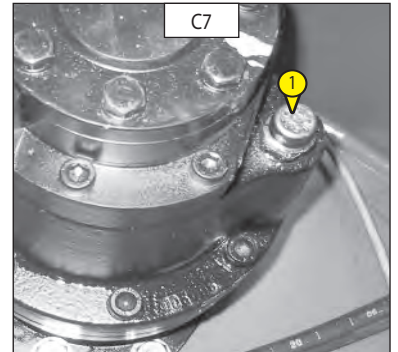

C8 - TURRET ORIENTATION CROWN

GREASE

- The bearing raceways and gears must be lubricated every 250 hours of operation as well as before and after any long period at a standstill.
- Grease to use: see the LUBRICANTS section.
- Remove the left-hand casing from the chassis Ref. 1 (see Fig. C8/1).
- Find the 2 grease nipples Ref. 1 (Fig. C8/2) and thoroughly grease the crown, while orienting the turret.
- Refit the left-hand casing on the chassis (see Fig. C8/1).

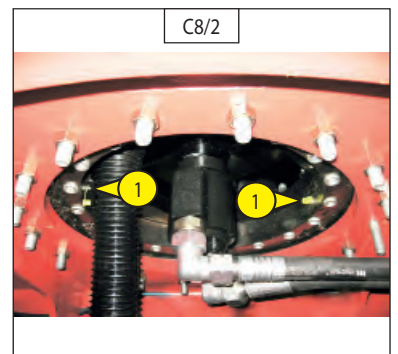
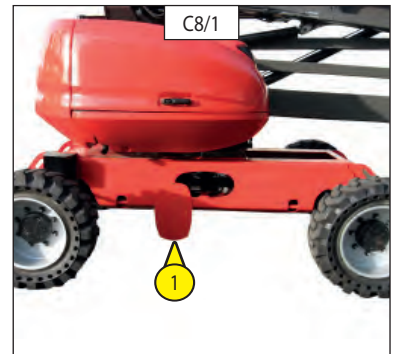

- Apply lubricant to the teeth of the crown and the pinion with a paintbrush (Fig. C8/3).
- Lubricant to use: see the LUBRICANTS section.



C9 - AXLES

GREASE

- Clean and then grease the following points (see the LUBRICANTS section for details of the grease) and remove the surplus.

LEGEND :

AXLE

HUB

JOINT

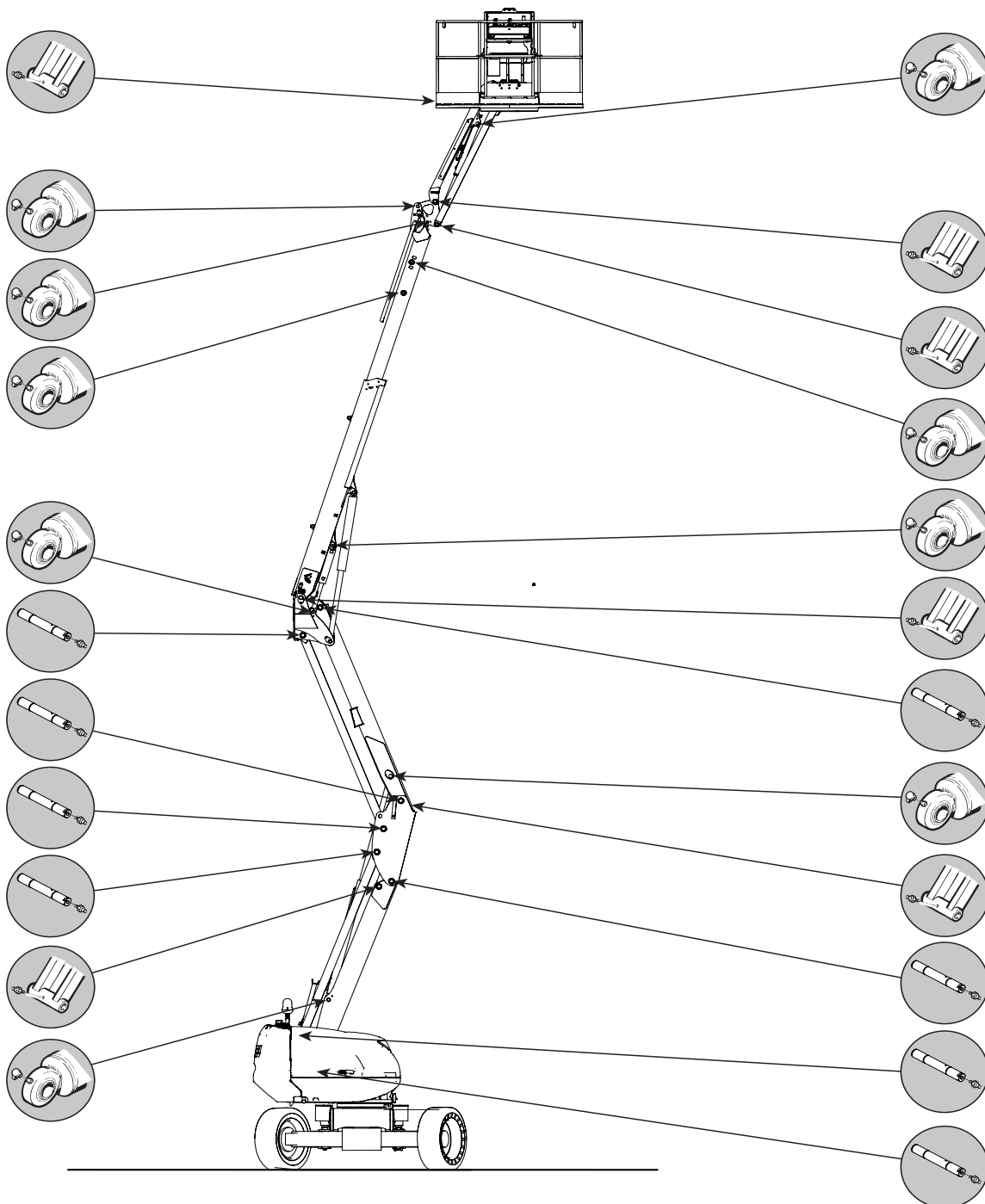
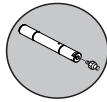

C10 - TIGHTNESS OF THE BOLTS FIXING THE AXLE ASSEMBLIES ON THE CHASSIS

CHECK

- The tightness of the bolts must be checked at the latest after the first 50 hours of operation, and every 250 hours of operation thereafter.
- The tightening torque for the bolts is 28.5 daN.m \pm 10 %.
- 1 daN = 1 Kg.

C11 - ARM POSITION SENSORS

CHECK

For this operation, fold the arms into transport position.

- Make a translation movement at transport speed
- Raise the arms or extend the telescope
- Move forward
- The lifting platform should switch over to operating speed.



In the event of a malfunction occurring, prevent the lifting platform from being used. Contact your dealer.

C12 - TILT SENSOR

CHECK

Fold the arms for this operation.

- Set the lifting platform in a tilted position greater than the authorised tilt (see: 2 - DESCRIPTION: SPECIFICATIONS).
- The movements for extending the telescope and raising the arms should be blocked (the tilt indicator light is lit in the basket and the buzzer is activated intermittently in the basket).



In the event of a malfunction occurring, prevent the lifting platform from being used. Contact your dealer.

C13 - OVERLOAD SENSORS

CHECK

Fold the arms into transport position for this operation.

- Place a higher weight than that indicated in the basket (see: 2 - DESCRIPTION: SPECIFICATIONS).
- The movements for extending the telescope and raising the arms should be blocked (the tilt indicator light is lit in the basket and the buzzer is activated continuously in the basket).



In the event of a malfunction occurring, prevent the lifting platform from being used. Contact your dealer.

C14 - COOLING CIRCUIT HOSES

CHECK



If the cooling circuit hoses are damaged or if coolant leaks, this can cause overheating or severe burns.

- Open the bonnet.
- Visually check the condition of the cooling circuit hoses and the tightening collars. If these are blistered, hardened or cracked, replace them immediately (replace all the cooling circuit hoses and the tightening collars, at least every two years). (Contact your dealer)

C15 - FUEL FILTER

CLEAN

- Set the lifting platform on a horizontal surface, with the engine switched off.
- Open the left-hand cowl.
- Close the fuel tap 1 (Fig. C15/1) to the OFF position.
- Carefully clean the exterior of the filter and its holder to prevent dust from entering the system.
- Unscrew the retaining ring 2, remove the container 3 (Fig. C15/2) and clean the interior with a paintbrush impregnated with clean diesel.
- Remove the filter cartridge 4 (Fig. C15/2) and plunge it in diesel to rinse it.
- Refit the assembly.
- Open the fuel tap 1 (Fig. C15/1) to the ON position.
- Bleed the fuel supply circuit (see: 3 - MAINTENANCE: G1 – FUEL SUPPLY CIRCUIT).



If the fuel is contaminated with dust or dirt, the injection pump and the injectors wear more rapidly. To avoid this, regularly clean the fuel filter container.

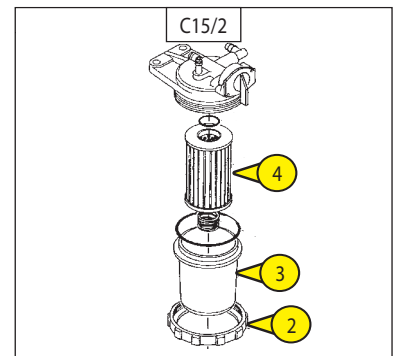
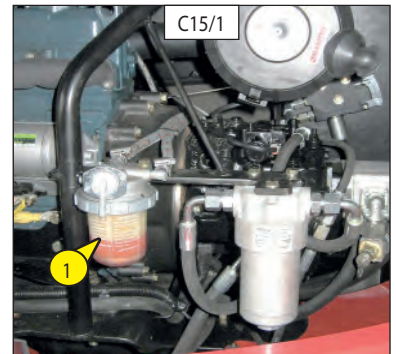

C16 - ALTERNATOR/FAN/CRANKSHAFT BELT TENSION

ADJUST

- Open the left-hand cowl.
- Check the condition of the belt for signs of wear or cracking and replace, it if necessary (see 3 - MAINTENANCE: FILTER ELEMENTS AND BELTS).
- Check the tension between the crankshaft and alternator pulleys.
- Under thumb pressure (98 N), the tension A (Fig. C16/1) should be be 7 to 9 mm (Fig. C16/1).
- Adjust, if necessary.
- Loosen the bolts 1 (Fig. C16/2) two or three turns.
- Swivel the alternator assembly to get the required belt tension.
- Retighten the bolts 1 (fig. C16/2).



If you replace the alternator belt, recheck the belt tension after the first 20 hours of operation.

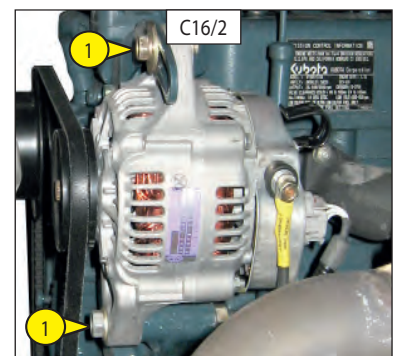
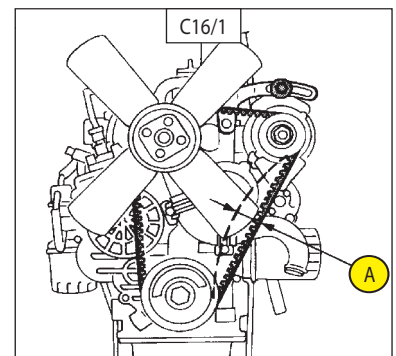

C17 - MACHINE STICKERS

CHECK

- Check that the safety stickers are present (see: 1 – SAFETY STICKERS).



C18 - OVERLOAD

CHECK

- The overload must activate at between 1.1 and 1.2 times the nominal load (see CHAPTER 2 - General characteristics).

Expected result:

- Nominal load 230 Kg: activation load between 253 kg and 276 kg

- The overload sensors must activate at the same time.

◀ Refer to the repair manual for information about adjusting the overload

C19 - STOPPING DISTANCE

CHECK

STOPPING DISTANCE ON HORIZONTAL GROUND:

- The stopping distance is tested on flat ground with 1.1 times the nominal load in the basket.
- Reach maximum speed and then release the control.

Expected result:

On horizontal ground	Stopping distance
Transport speed	1400 + or - 300
Working speed	160 + or - 50

CHECK BRAKE HOLDING ON A SLOPE

- Place the nacelle on a nominal 25% slope static with 1.1 times the nominal load in the basket.

Expected result: no slipping of the nacelle must be detected after one minute.

D - EVERY 500 HOURS OF OPERATION

D1 - DRY AIR FILTER CARTRIDGE

REPLACE

The air used for combustion is purified by a dry air filter. It is therefore forbidden to use the lifting platform with the cartridge removed or damaged.

- Open the left-hand cowl.
- Unclip the clips 1 (Fig. D1/1) and remove the cover 2 (Fig. D1/1).
- Carefully remove the cartridge 3 (Fig. D1/2) to reduce any dust falling as much as possible.
- Leave the safety cartridge in place.
 - Carefully clean the following parts with a clean, damp, lint-free cloth.
 - The interior of the filter and the cover.
 - The interior of the filter inlet hose.
 - The seal holders in the filter and the cover.
- Check the condition of the engine connection pipework and its fasteners as well as the connection and the condition of the clogging indicator on the filter.
- Before fitting, check the condition of the new filter cartridge (see: 3 - MAINTENANCE: FILTER ELEMENTS AND BELTS).
- Insert the cartridge in the axis of the filter and push it in by pressing on the circumference and not on the centre.
- Refit the lid, orienting the valve to the rear.

When using the machine in a very dusty atmosphere, see the FILTER ELEMENTS AND BELTS section.

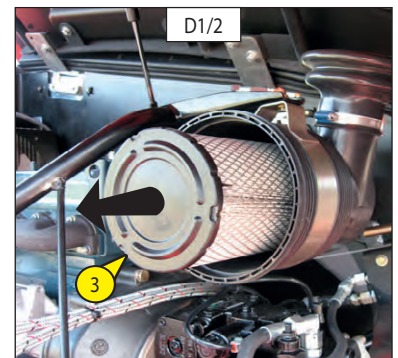
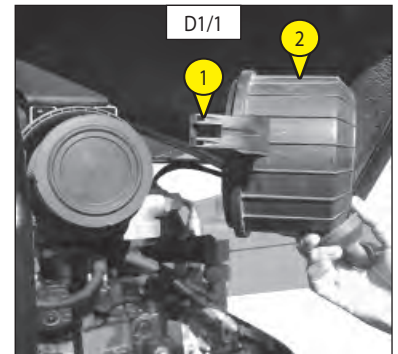

D2 - FUEL FILTER CARTRIDGE

REPLACE

- Open the left-hand cowl.
- Carefully clean the exterior of the filter and its holder to prevent dust from entering the system.
- Close the fuel tap 1 (Fig. D2/1) to the OFF position.
- Unscrew the retaining ring 2, remove the container 3 (Fig. D2/2) and clean the interior with a paintbrush impregnated with clean diesel.
- Throw away the filter cartridge 4 (Fig. D2/2).
- Reinstall the assembly with a new filter (see 3 – MAINTENANCE: FILTER ELEMENTS AND BELTS section).

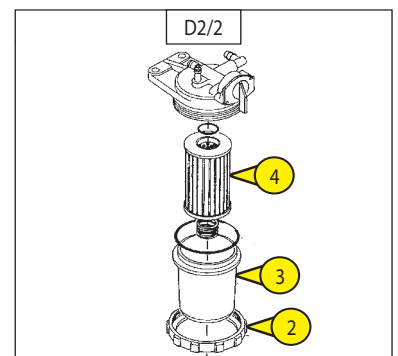
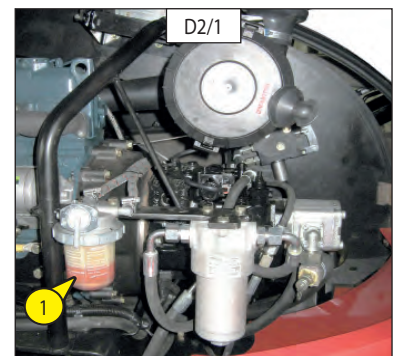

D3 - HYDROSTATIC TRANSMISSION OIL FILTER CARTRIDGE

REPLACE

REPLACING THE HYDROSTATIC TRANSMISSION OIL FILTER CARTRIDGE

- Switch off the engine.
- Lift the cowl on the engine side.
- Unscrew the filter body 1 (Fig. D3).
- Remove the hydrostatic transmission oil filter cartridge and replace it with a new one.
- Ensure that the cartridge is correctly positioned and refit the cover.



Do not operate the lifting platform without a cartridge; this would immediately cause damage to the hydrostatic pump's hydraulic transmission circuit.

CLEANING OUT THE HYDRAULIC CIRCUIT

- Let the engine turn over for 5 minutes without using the lifting platform.

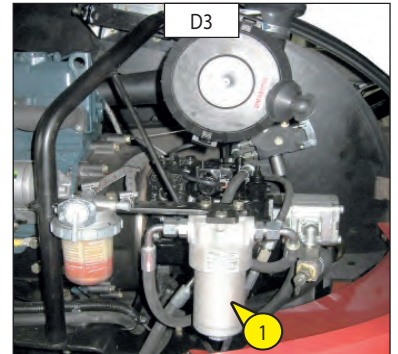

D4 - AUXILIARY HYDRAULIC OIL FILTER CARTRIDGE

REPLACE

- With the machine stopped and the battery cutout in the OFF position.
- Unscrew the filter body 1 (Fig. D4).
- Remove the filter cartridge and replace it with a new one (see "FILTER ELEMENT" section).
NB: Pay attention to the direction for fitting.
- Refit the filter body 1 (Fig. D4).



Carefully clean the exterior of the filter and its surroundings before performing any work in order to avoid any risk of pollution getting into the hydraulic circuit.

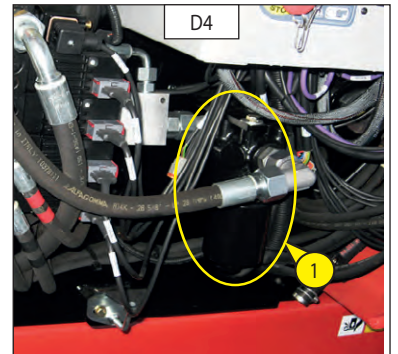

D5 - HYDRAULIC OIL

DRAIN - REPLACE

Set the platform on a horizontal surface in Transport position, with the engine off.

DRAINING THE OIL

- Place a tray under the draining plug Ref. 1 (Fig. D5/1 and D5/2) and unscrew the collar Ref. 2 (Fig. D5/2).
- Withdraw the draining plug Ref. 1 (Fig. D5/2).
- Remove the filling plug 3 (Fig. D5/4) to facilitate drainage.
- Remove the Durit Ref. 5 (Fig. D5/3) from the auxiliary pump before draining the oil residue from it.
- Re-tighten the Durit Ref. 5 on the auxiliary pump.
- Remove the Durit Ref. 6 in order to access the inlet filter Ref. 7 (Fig. D5/3 and D5/4).
- Remove and clean the inlet filter using a jet of compressed air Ref. 7 or replace it.
- Re-fit the inlet filter Ref. 7 and the Durit Ref. 6.

CLEANING THE STRAINER

- Remove the strainer Ref. 3 (Fig. D5/4), clean it using a jet of compressed air.
- Put the strainer back in place.

REFILLING THE OIL



Use an oil bath and a very clean funnel; clean the top of the oil can before filling.

- Refit the drain plug 1 (Fig. D5/1) and tighten it.
- Refill with hydraulic oil (see the LUBRICANTS section) via the filling hole 4 (Fig. D5/4).
- The oil level should be above the red mark on the gauge 5 (Fig. D5/5).



Dispose of the drained oil in an environmentally-friendly manner.

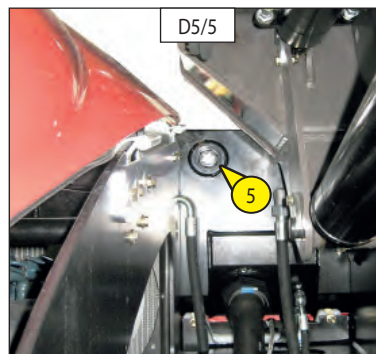
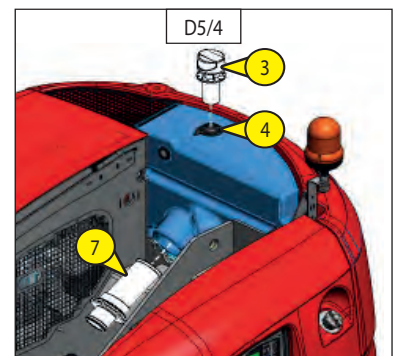
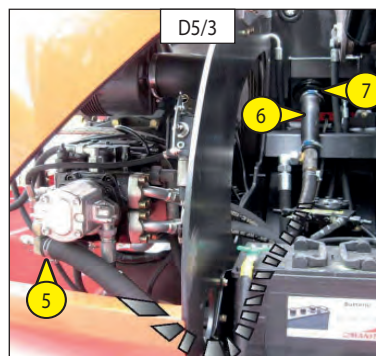
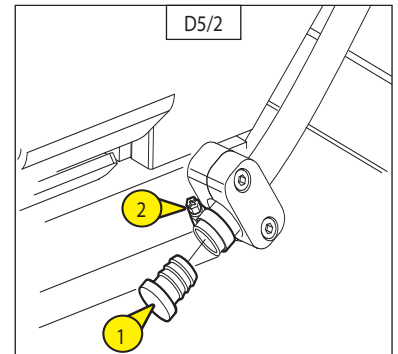
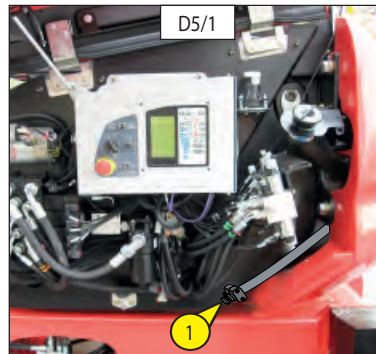

D6 - CONDITION OF THE HOSES

CHECK

- Check the apparent condition (cracking) of the hoses subject to heat stresses and UV; their technical characteristics may have altered (porosities).



BEWARE OF LEAKS

Hydraulic oil escaping under high pressure can pierce the skin and cause severe lesions. If you are injured by a jet of oil under pressure, immediately consult a doctor.

If you are in doubt about any leak, do not search with your hand: check with a piece of cardboard while protecting your hands and your body. For your safety's sake, replace worn hoses

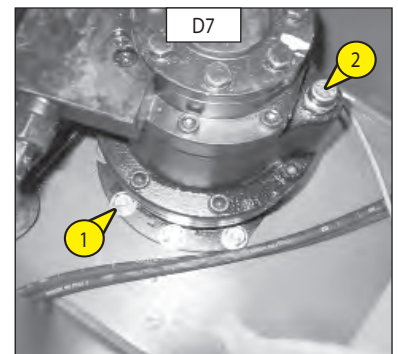

D7 - TIGHTENING THE TURRET ROTATION MOTOR'S BOLTS

CHECK

Set the lifting platform on a horizontal surface with the engine switched off.

- Check that the nine bolts are tight 1 (Fig. D7).
- The tightening torque for the screws is 8 daN.m \pm 10%.
- 1 daN = 1 Kg.

D8 - TURRET MOTOR REDUCER BRAKE REDUCER

DRAIN - REPLACE

Set the lifting platform on a horizontal surface with the engine switched off.

- Remove the turret's inner cover.
- The motor reducer is presented with the valve unit to the rear.
- Remove the sniffer/filling cap 2 (Fig. D7) to ensure good drainage.
- Note the drain plug 3 located on the right-hand side reducer unit's sole plate (Fig. D8).
- Place a (small) receptacle to catch the oil.
- Unscrew the drain plug.



Dispose of the drained oil in an environmentally friendly manner.

- Screw in the drain plug again
- Use a syringe to fill the reducer via the sniffer/filling hole 2 (Fig. D7). The oil capacity is 1.3 litres and the level is correct when the sniffer is full of oil.
- Refit the sniffer/filling cap 2 (Fig. D7).

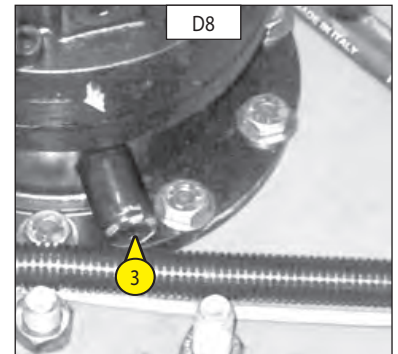

D9 - TIGHTENING THE UNIVERSAL JOINT'S BOLTS

CHECK

Set the lifting platform on a horizontal surface with the engine switched off.

- Check the tightness of the eight bolts (four at each end) 1 (Fig. D9/1) and 2 (Fig.D9/2) located under the chassis.
- The tightening torque of the screws is 8 daN.m \pm 10 %.
- 1 daN = 1 Kg

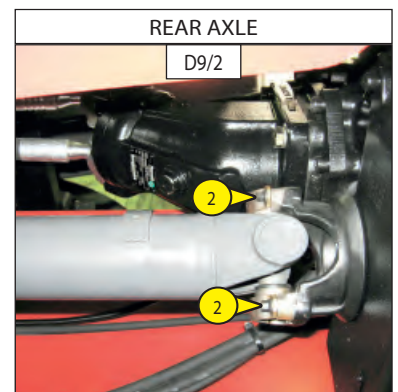
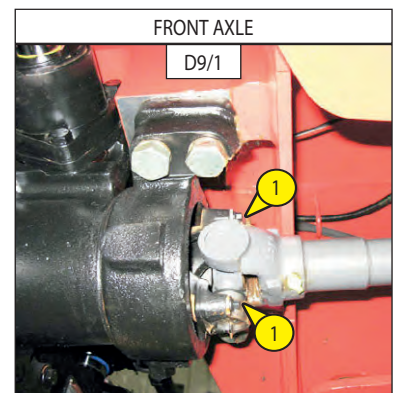

D10 - DENSITY OF THE BATTERY ELECTROLYTE

CHECK

The electrolyte's density varies according to the temperature but a minimum level of 1260 at 16°C must be maintained.

In the hatched section (Fig. D10), the battery is normally charged.

Above the hatched section, the battery must be recharged.

The density must not vary by 0.025 unit from one battery element to another.

- Open the battery cover.
- Check the electrolyte density in each battery element with an acidometer.
- Never check after having added distilled water. Recharge the battery and wait 1 hour before checking the battery electrolyte's density.



Manipulating and servicing a battery can be dangerous; take the following precautions:

- **Wear protective goggles.**
- **Keep the battery horizontal when manipulating it.**
- **Never smoke or work close to a naked flame.**
- **Work in a sufficiently well-ventilated area.**
- **If some electrolyte splashes onto your skin or in your eyes, rinse the affected area thoroughly with cold water for 15 minutes and call a doctor.**

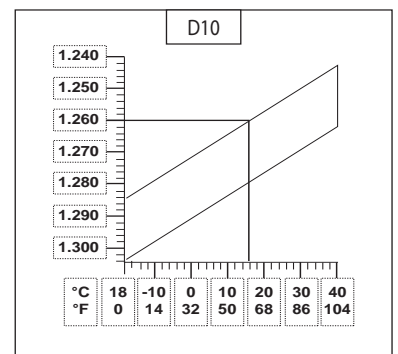

D11 - TIGHTENING THE BOLTS ON THE TURRET ORIENTATION CROWN GEAR

CHECK

- The tightness of the screws must be checked at the latest after 50 hours of operation. This check must then be repeated every 500 hours of operation.
- The tightening torque for the screws is 27 daN.m \pm 10 %.
- 1 daN = 1 Kg.

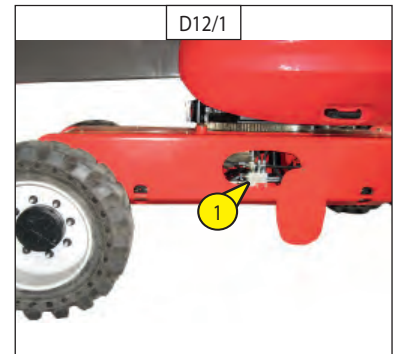

D12 - BRAKING

CHECK

- Check the braking system by disconnecting the coil 1 (Fig. D12/1 and D12/2) from the hydraulic block on the chassis (to access the block, remove the casing on the chassis' right-hand side) and make a translation movement.



The lifting platform must not move forward.

- After the test, reconnect the coil.

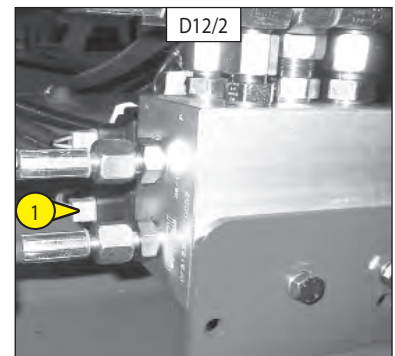

D13 - ALTERNATOR/FAN/CRANKCASE BELT

REPLACE

- Open the left-hand cowl.
- Loosen the bolts 1 (fig. D13/1) two or three turns.
- Swivel the alternator assembly to free the belt and the replace it with a new one (see: 3 - MAINTENANCE: FILTER ELEMENTS AND BELTS).
- Adjust the tension between the crankcase and alternator pulleys.
- Under thumb pressure (98 N), the tension should be 7 to 9 mm (Rep. A-Fig. D13/2)
- Retighten the bolts 1 (Fig. D13/1).



Recheck the belt tension after the first 20 hours of operation.

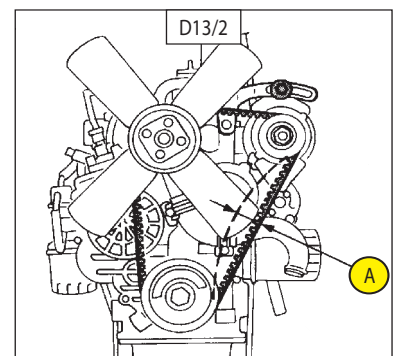
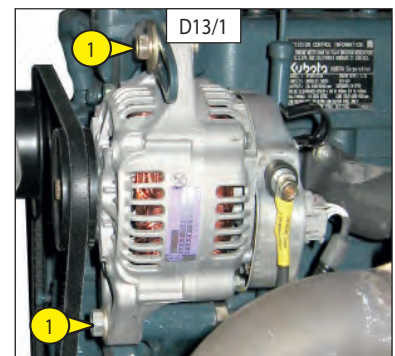

D14 - IC ENGINE OIL

DRAIN - REPLACE

D15 - IC ENGINE OIL FILTER

REPLACE

- Set the lifting platform on a horizontal surface, leave the engine running at tickover speed for a few moments and then switch it off.

DRAINING THE OIL

- Open the left-hand cover.
- Lay a receptacle on the ground
- Remove the blanking cap 1 (Fig. D15/1) located under the engine.
- Remove the filling cap 2 (Fig. D15/2) to ensure good drainage.
- When draining is complete, screw the plug back in



Dispose of the drained oil in an environmentally friendly manner.

REPLACING THE FILTER

- Remove the engine oil filter 4 (Fig. D15/3) and throw it away, together with its seal.
- Clean the filter support with a clean, lint-free cloth.
- Light oil the new seal.
- Refit the oil filter on its support.



Only tighten the oil filter by hand and then lock it with a quarter turn from a filter wrench.

REFILLING WITH OIL

- Ensure that the plug 1 (Fig. D15/1) is in place and tight.
- Fill up with oil (see the LUBRICANTS section) via the filling hole 2 (Fig. D15/2).
- Wait a few moments for the oil to flow into the sump.
- Check the level with the dipstick 3 (Fig. D15/2).
- Start the engine and let it run for a few moments.
- Check for any leaks from the drain plug and the engine oil filter.
- Stop the engine, wait a few moments and check that the level is between the two upper notches on the dipstick A (Fig. D15/2).
- Top up, if necessary.

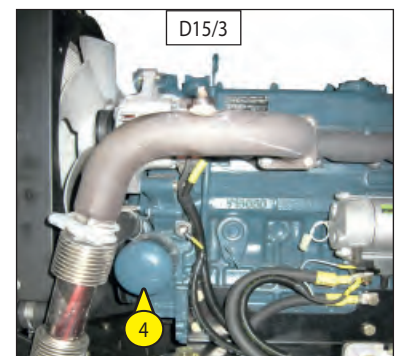
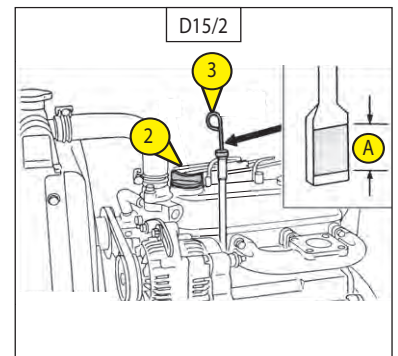
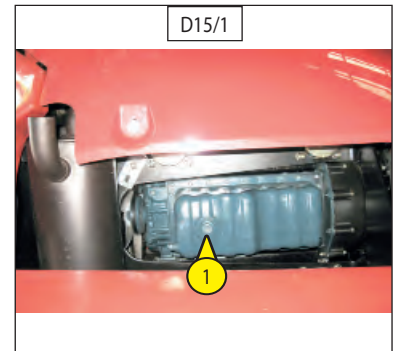

E - EVERY 1000 HOURS OF OPERATION

E1 - FUEL TANK

DRAIN - CLEAN



Never smoke or approach the machine with a naked flame during this operation.

Set the lifting platform on a horizontal surface, rotate the machine 90° (so as to avoid having the drain plug over the chassis) and switch off the engine.

- Check visually and by touch the parts likely to have leaks in the fuel circuit and the tank.
- In the even of a leak, contact your dealer.



Never attempt to make a weld or any other operation by yourself; this could cause an explosion or a fire.

- Lay a receptacle under the drain plug 1 (Fig. E1/1) and unscrew the plug.
- Let the diesel flow out and rinse with ten litres of clean diesel poured in through the filling hole 2 (Fig. E1/2).
- Refit and tighten down the drain plug 1 (Fig. E1/1) (tightening torque 3 to 4 daN/m).
- Fill the fuel tank with clean diesel, filtered through a strainer or a clean lint-free cloth and refit the filling cap (Fig. E1/2).

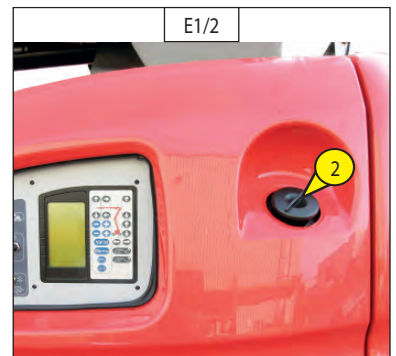
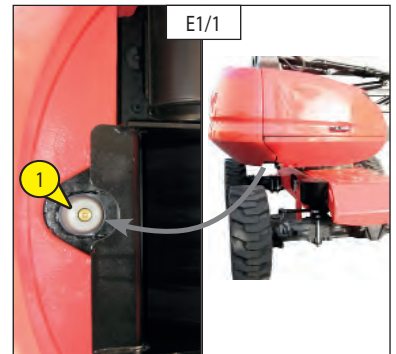

E2 - DRY AIR FILTER SAFETY CARTRIDGE

REPLACE

- Open the left-hand cover.
- Remove the dry air filter cartridge Ref. 1 (Fig. E2/1) (See § D1).
- Remove the dry air filter safety cartridge Ref. 2 (Fig. E2/2) and replace it with a new one.
- Refit the assembly (see § D1).

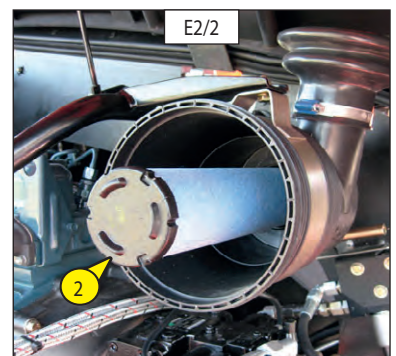
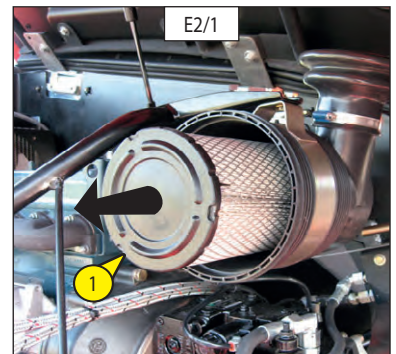

FOR 160 ATJ E3: AND 180 ATJ 2 E3

E3 - FRONT AND REAR AXLE OIL

DRAIN - REPLACE

Set the platform on a horizontal surface with the engine off and the differential oil still warm.

- Place a receptacle under the drain plugs 1 (Fig. E3/1: front axle) and 3 (Fig. E3/3: rear axle).
- Remove the level and filling plugs 2 (Fig. E3/2: front axle) and 4 (Fig. E3/4: rear axle) to ensure good drainage.



Dispose of the drained oil in an environmentally-friendly manner.

- Refit the drain plugs 1 (Fig. E3/1: front axle – tightening torque 8 daNm) and 3 (Fig. E3/3: rear axle) and tighten them.
- Refill with oil (see the LUBRICANTS section) via the filling holes 2 (Fig. E3/2: front axle) and 4 (Fig. E3/4: rear axle).
- The level is correct when the oil is flush with the hole.
- Check for any leaks from the drain plugs.
- Refit the drain and level plugs 2 (Fig. E3/2: front axle) and 4 (Fig. E3/3: rear axle) and tighten them.

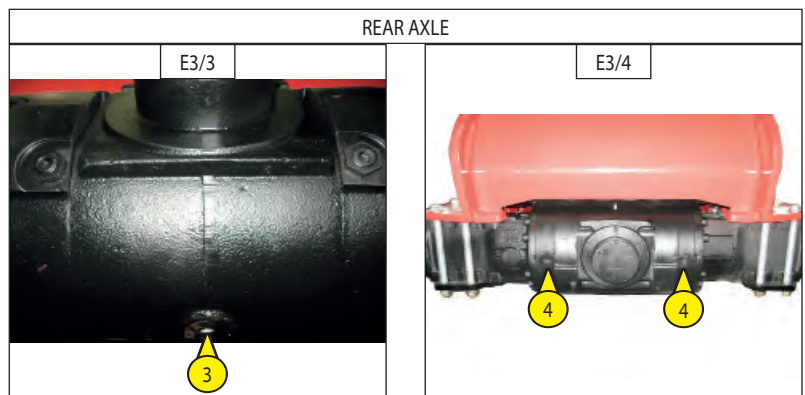
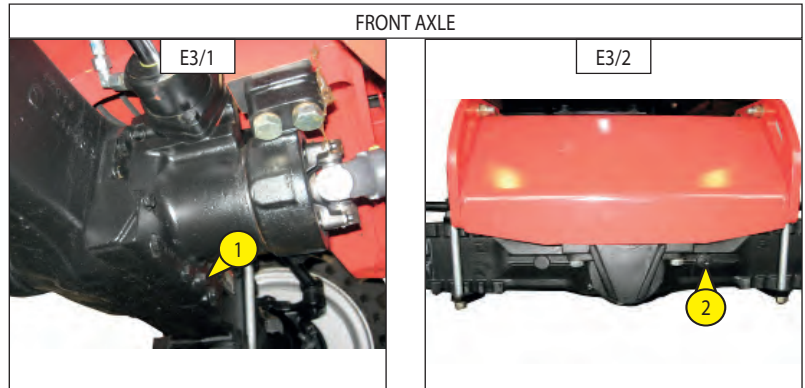

E4 - DIFFERENTIAL OIL

DRAIN - REPLACE

Set the platform on a horizontal surface with the engine off and the differential oil still warm.

- Place a receptacle under the drain plug 1 (Fig. E4/1) and remove the filling plug 3 (Fig. E4/2) to ensure good drainage.
- Refill with oil (see the LUBRICANTS section) via the filling hole 3 (Fig. E4/2).
- The level is correct when the oil is flush with the hole 2 (Fig. E4/1).
- Refit the filling plug 3 (Fig. E4/2) and tighten it.
- Check the level via the hole 2 (Fig. E4/1).

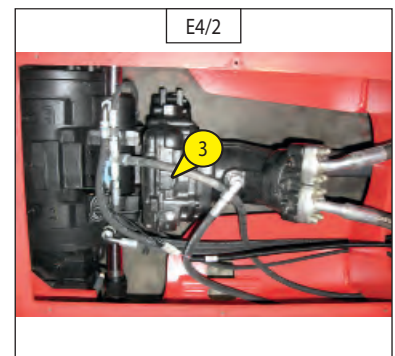
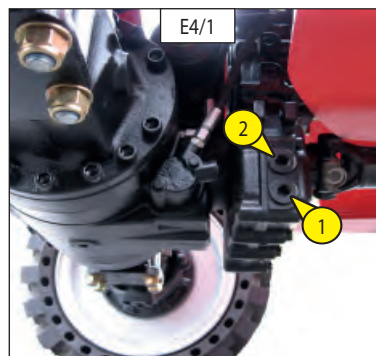

E5 - FRONT AND REAR WHEEL REDUCER OIL

DRAIN - REPLACE

Set the platform on a horizontal surface with the engine off and the reducers' oil still warm.

- Drain and replace the oil of each of the front and rear wheel reducers.
- Set the drainage plug 1 (Fig. E5) to position A.
- Place a receptacle under the drain plug and unscrew it.
- Leave the oil to drain out completely.



Dispose of the drained oil in an environmentally-friendly manner.

- Set the drain hole to position B, i.e. to level hole.
- Refill with oil (see the LUBRICANTS section) via the level hole 1 (Fig. E5).
- The level is correct when the oil is flush with the hole.
- Refit the drain plug 1 (Fig. E5) and tighten it.
- Perform the same operation for each of the wheel reducers.

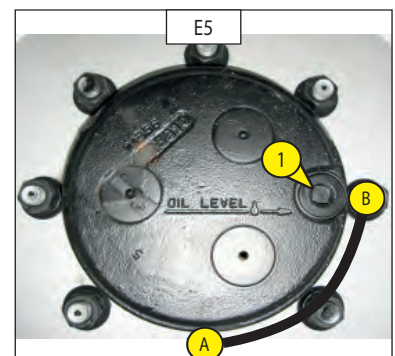

FOR 160 ATJ S E3:

E3 - FRONT AND REAR AXLE OIL

DRAIN - REPLACE

Set the lifting platform on a horizontal surface with the engine switched off and the differential oil still warm.

- Place a receptacle under the drain plugs 1 (Fig. E3/6: front axle) (Fig. E3/7: rear axle).
- Remove the level and filling plug 2 (Fig. E3/6: front axle) (Fig. E3/7: rear axle) to ensure good drainage.



Dispose of the oil in an environmentally-friendly manner.

- Refit and tighten the drain plugs 1 (Fig. E3/6: front axle (tightening torque 8 daNm)) (Fig. E3/7: rear axle (tightening torque 8 daNm)) and 3 (Fig. E3/8: differential (tightening torque 8 daNm))
- Top up with oil (See the LUBRICANTS section) via the filling hole 2 (Fig. E3/6: front axle) (Fig. E3/7: rear axle).
- The level is correct when the oil is flush with the hole.
- Check for any leaks from the drain plugs.
- Refit and tighten the level and filling plug 2 (Fig. E3/6: front axle) (Fig. E3/7: rear axle) and 4 (Fig. E3/8: differential) (tightening torque 6 daNm).

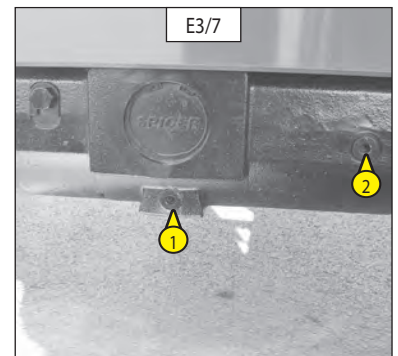
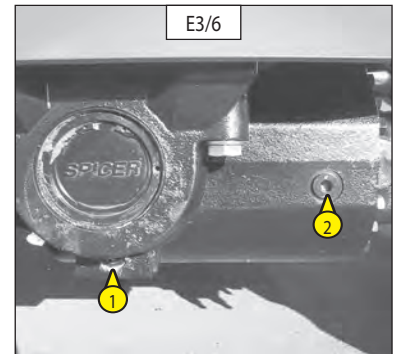

E4 - DIFFERENTIAL OIL

DRAIN - REPLACE

Set the lifting platform on a horizontal surface with the engine switched off and the differential oil still warm.

- Place a receptacle under the drain plug 3 and remove the level and filling plug 4 (Fig. E3/8: differential).
- Refit and tighten the drain plugs 3 (Fig. E3/8: differential (tightening torque 8 daNm))
- Top up with oil (See the LUBRICANTS section) via the filling hole 4 (Fig. E3/8: differential).
- The level is correct when the oil is flush with the hole.
- Refit and tighten the level and filling plug 4 (Fig. E3/8: differential) (tightening torque 6 daNm).

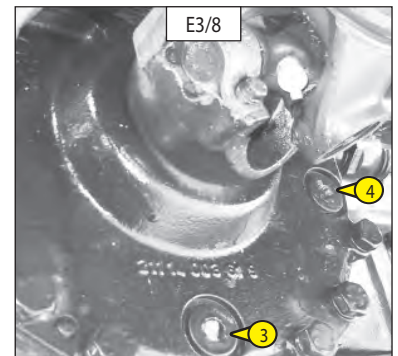

E5 - FRONT AND REAR WHEEL REDUCER OIL

DRAIN - REPLACE

Set the lifting platform on a horizontal surface with the engine switched off and the reducers' oil still warm.

- Drain and replace the oil in each front wheel reducer.
- Set the drain plug 1 (Fig. E4) to position A.
- Place a receptacle under the drain plug and loosen the plug.
- Let the oil drain out completely.



Dispose of the oil in an environmentally-friendly manner.

- Set the drain hole to position B, i.e. to the level hole.
- Top up with oil (See the LUBRICANTS section) via the level hole 1 (Fig. E4).
- The level is correct when the oil is flush with the hole.
- Refit and tighten the drain plug 1 (Fig. E4) (tightening torque 8 daNm).
- Perform the same operation on each rear wheel reducer.

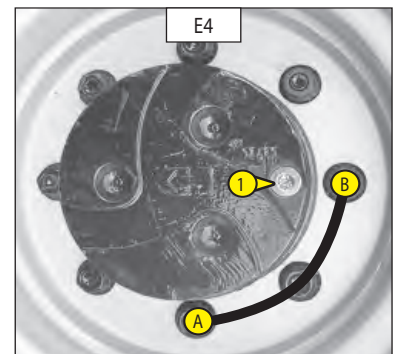

E6 - HYDRAULIC CIRCUIT STRAINER

CLEAN

- Drain the oil (see § D15)
- Remove the hose 2 (Fig. E6/1).
- Unscrew the strainer from the oil bath 1 (Figs. E6/1 and E6/2).
- Clean the strainer with a jet of compressed air.
- Screw the strainer 1 back into the oil bath and refit the hose 2 on the strainer (Fig. E6/1).
- Refill with hydraulic oil (see § D6) (see the LUBRICANTS section).

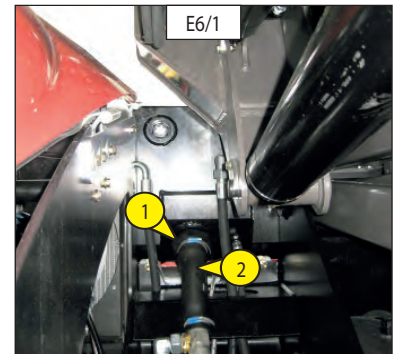

E7 - CONDITION OF THE CYLINDERS (LEAKS, RODS)

CHECK

- Check the condition of the cylinders. There must be no:
 - Hydraulic leaks from the seals and the valve blocks
 - Impacts on the cylinder rods

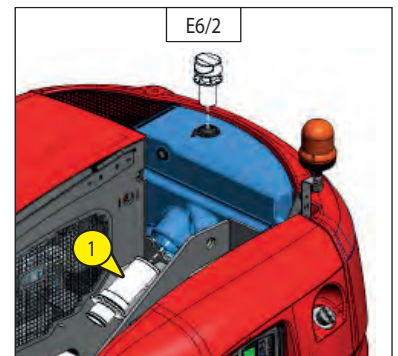

E8 - CONDITION OF THE CABLE BUNDLES AND THE CABLES THEMSELVES

CHECK

- Inspect the following sectors, check the condition of the bundles: no deterioration and nothing loose.
 - Base control console,
 - Hydraulic block,
 - Battery,
 - Intermediate joint,
 - Basket control console.

E9 - ENGINE SILENTBLOCKS (*)

CHECK

E10 - ENGINE SPEEDS (*)

CHECK

E11 - HYDROSTATIC TRANSMISSION CIRCUIT PRESSURES (*)

CHECK

E12 - START OF HYDROSTATIC TRANSMISSION CONTROL (*)

CHECK - ADJUST

E13 - MOVEMENT SPEEDS (*)

CHECK

*(Contact your dealer)

F - EVERY 2000 HOURS OF OPERATION

Perform the operations described above as well as the following operations.

F1 - COOLANT

DRAIN - REPLACE

This series of operations must only be performed as necessary or once a year, on the approach of winter.

Set the lifting platform on a horizontal surface with the engine switched off and cold.



Do not remove the radiator cap when the engine is hot. Then, gently loosen the cap up to the stop to release any excessive pressure before removing the cap completely. If the engine overheats, steam may spurt from the radiator or the emergency reservoir, possibly causing severe burns.

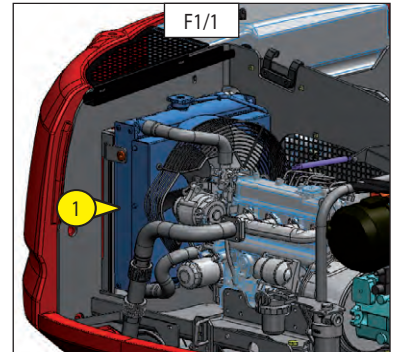

DRAINING THE COOLANT

- Open the left-hand cover and locate the radiator 1 (Fig. F1/1) and the drain cocks 2 (Fig. F1/2) and 4 (Fig. F1/3)
- To drain the coolant, open the drain taps 2 (Fig. F1/2) and 4 (Fig. F1/3) and the radiator cap 3 (Fig. F1/2) all together.

NB: The fluid cannot be drained out completely while the radiator cap is kept closed.

- Leave the cooling circuit to drain completely, ensuring that the holes are not blocked.
- Check the condition of the rubber hoses and the fastenings and change the rubber hoses if necessary.

REFILLING WITH COOLANT

Close the drain cocks 2 (Fig. F1/2) and 4 (Fig. F1/3)

- Prepare the coolant (Fig. F1/4).
- Fill the cooling circuit slowly and completely via the filling hole 3 (Fig. F1/2).
- Refit the filling plug 3 (Fig. F1/2).
- Turn over the engine at idling speed for a few minutes.
- Check for any leaks.
- Check the level and top up if necessary.



The engine does not contain any anti-corrosion element and must be filled every year with a mixture containing at least 25% ethyl glycol based antifreeze.

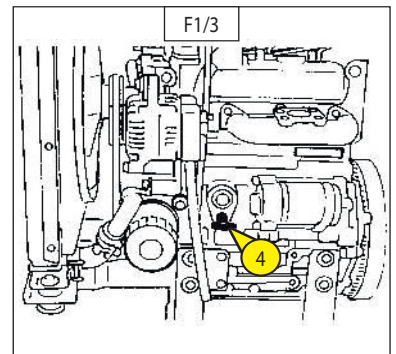
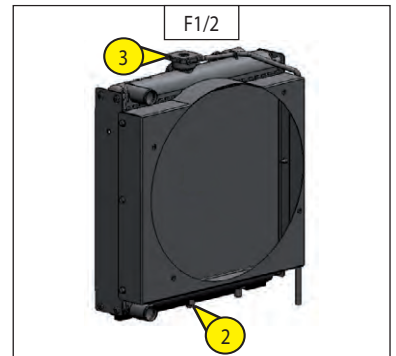

F1/4	
FREEZING POINT BASED ON % OF ANTIFREEZE	
ANTIFREEZE 5110 NF	TEMPERATURE
30 %	-16° C
33 %	-18° C
40 %	-25° C
50 %	-37° C



Perform the operations described above as well as the following operations.

F2 - VALVE PLAY (*)

CHECK - ADJUST

F3 - WATER PUMP AND THERMOSTAT (*)

CHECK

F4 - ALTERNATOR AND STARTER (*)

CHECK

F5 - HYDRAULIC OIL RESERVOIR (*)

CLEAN

F6 - HYDRAULIC CIRCUIT PRESSURES (*)

CHECK

F7 - HYDRAULIC CIRCUIT OUTPUTS (*)

CHECK

F8 - FUEL INJECTION PRESSURE (*)

CHECK

F9 - INJECTION PUMP (*)

CHECK

F10 - INJECTORS

(CONTACT YOUR DEALER)

F11 - RADIATOR (*)

CHECK - DESCALE

F12 - TURBOCOMPRESSOR (*)

CHECK

*(Contact your dealer)

G - OCCASIONAL MAINTENANCE

G1 - FUEL SUPPLY CIRCUIT

BLEEDING

This series of operations should only in the following case:

- A component in the supply circuit needs to be replaced or drained.
- The fuel tank is empty.
- Before the engine is used after a long period of inactivity.
- Ensure that there is sufficient fuel in the tank and turn the ignition key to the second notch to switch the machine on.
- Open the left-hand cover.

BLEEDING THE FUEL FILTER

- Refill the tank.
- Open the fuel filter tap 1 (Figs. G1/1 and G1/2).
- Slightly loosen the fuel filter vent plug 2 (Fig. G1/2).
- Use the lever 4 (Fig. G1/3) to operate the feed pump manually.
- Retighten the plug when no more bubbles form.
- Open the vent plug in the top of the injection pump 3 (Fig. G1/3).
- Use the lever 4 (Fig. G1/4) to operate the feed pump manually.
- Retighten the plug when no more bubbles form.

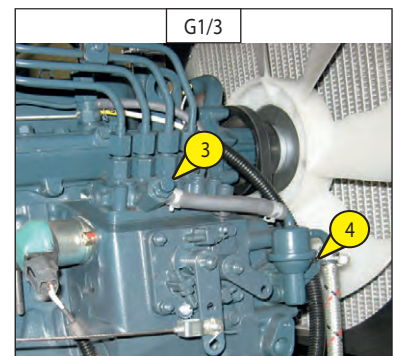
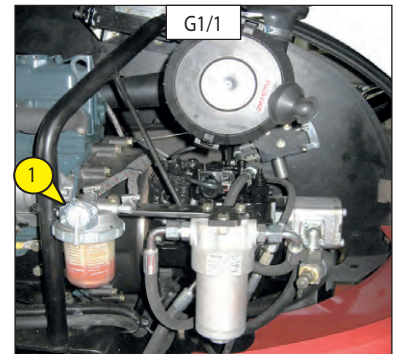

G2 - WHEEL

CHANGE

Or this operation, we recommend that you use the MANITOU hydraulic jack, reference 505507, and the MANITOU safety stand, reference 554772.

- Stop the lifting platform, if possible, on a firm, horizontal surface.
- Proceed to stop the lifting platform (see: 1 – SAFETY INSTRUCTIONS AND ADVICE: INSTRUCTIONS FOR DRIVING WHEN UNLADEN AND LADEN).
- Wedge the lifting platform in both directions on the axle opposite the wheel to be changed.
- Unscrew the wheel nuts on the wheel to be changed until they can be removed without much effort.
- Place the jack under the axle carrier, as close as possible to the wheel and adjust the jack (Fig. G2/1).
- Lift the wheel until it separates slightly from the ground and set the safety stand under the axle (Fig. G2/2).



The weight of one wheel is 134 kg.

- Unscrew the wheel nuts completely and remove them.
- Release the wheel by moving it to and fro and roll it to one side.
- Slip the new wheel onto the hub.
- Screw on the wheel nuts by hand; grease them, if necessary.
- Remove the safety stand and lower the lifting platform by means of the jack.
- Tighten the wheel nuts with a torque wrench (see: 3 - MAINTENANCE: B - EVERY 250 HOURS OF OPERATION for the tightening torque).

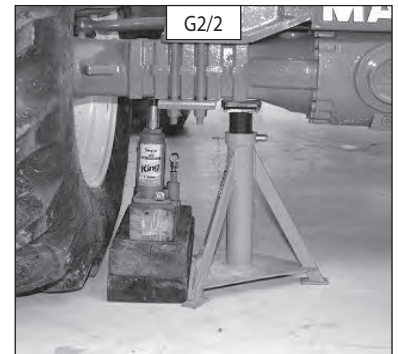

G3 - LIFTING PLATFORM

HOISTING WITH A SLING

- Note the position of the lifting platform's centre of gravity for lifting it.
- Place hooks on the anchoring points provided for this purpose.

- (A) Centre of gravity
- (B) Strap length
- (C) Axis line slinging rings

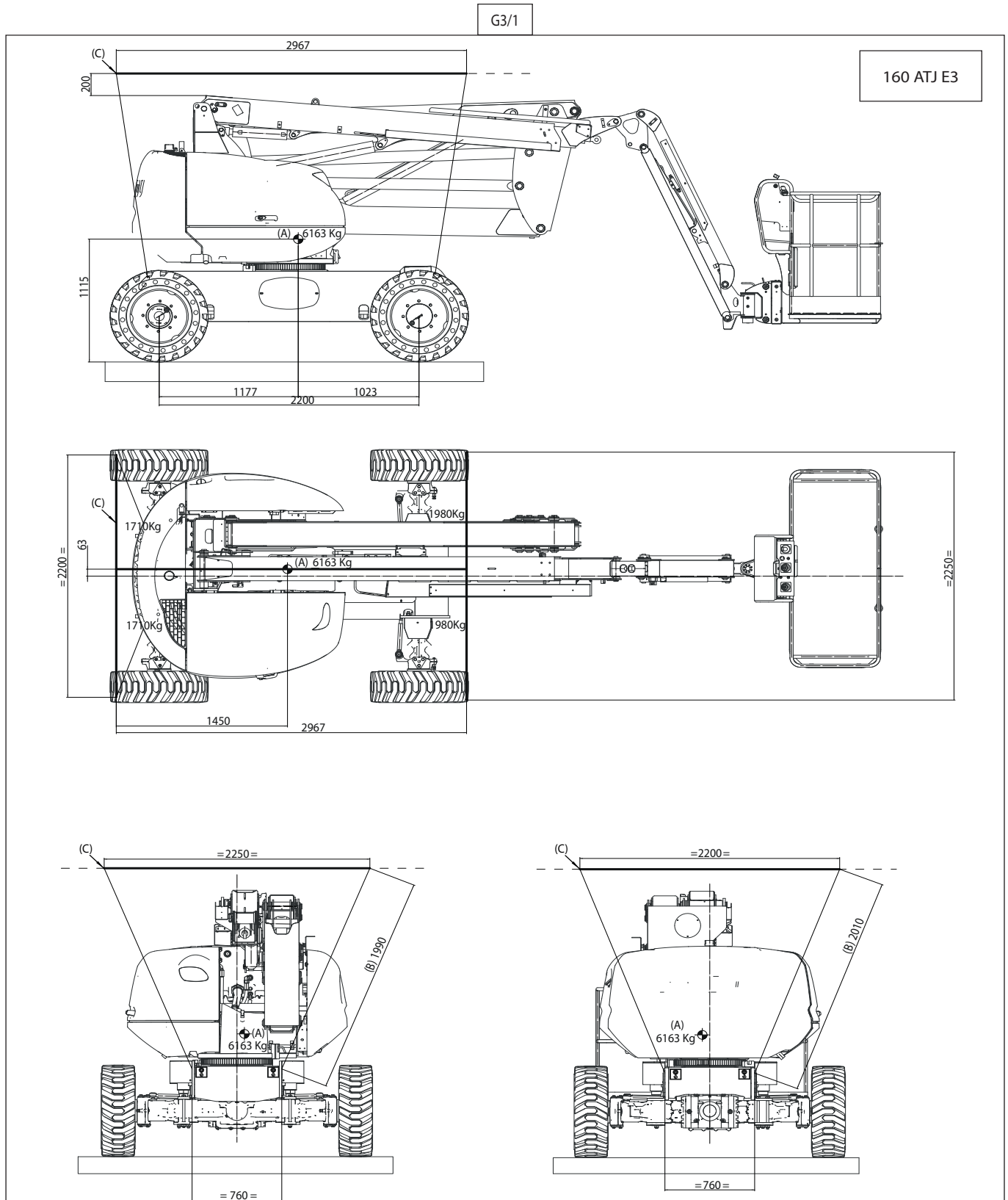

G3/2

160 ATJ S E3

MACHINE WEIGHT MEASURED	5850 kg
LOAD ON FRONT AXLE	2674
LOAD ON REAR AXLE	3176

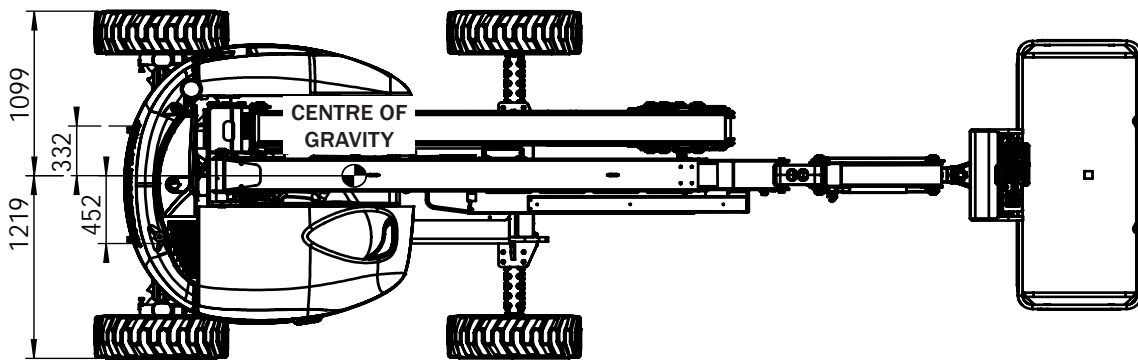
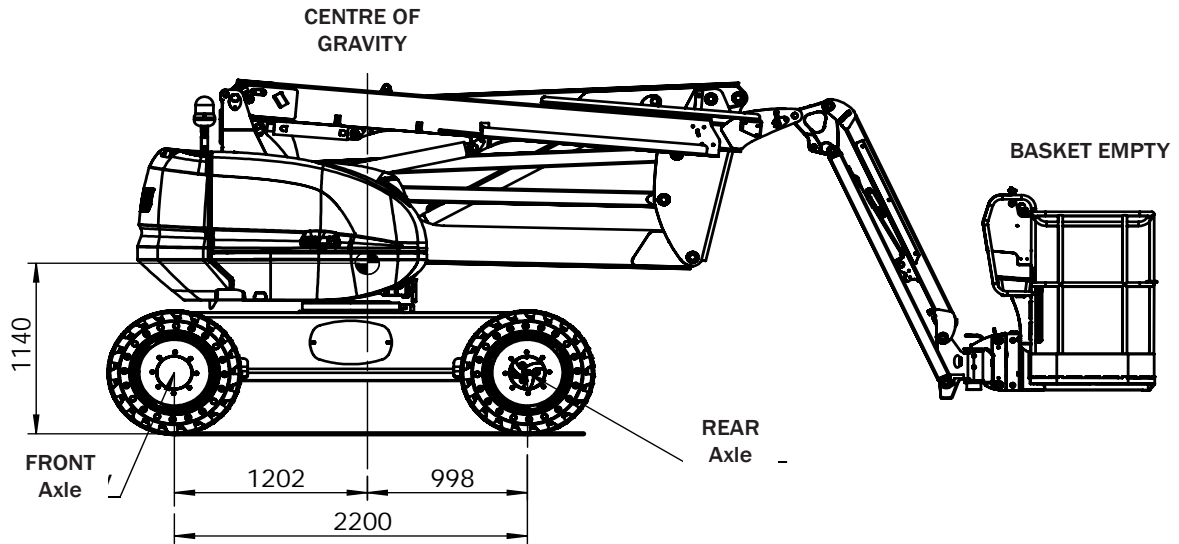

G3/3

180 ATJ 2 E3

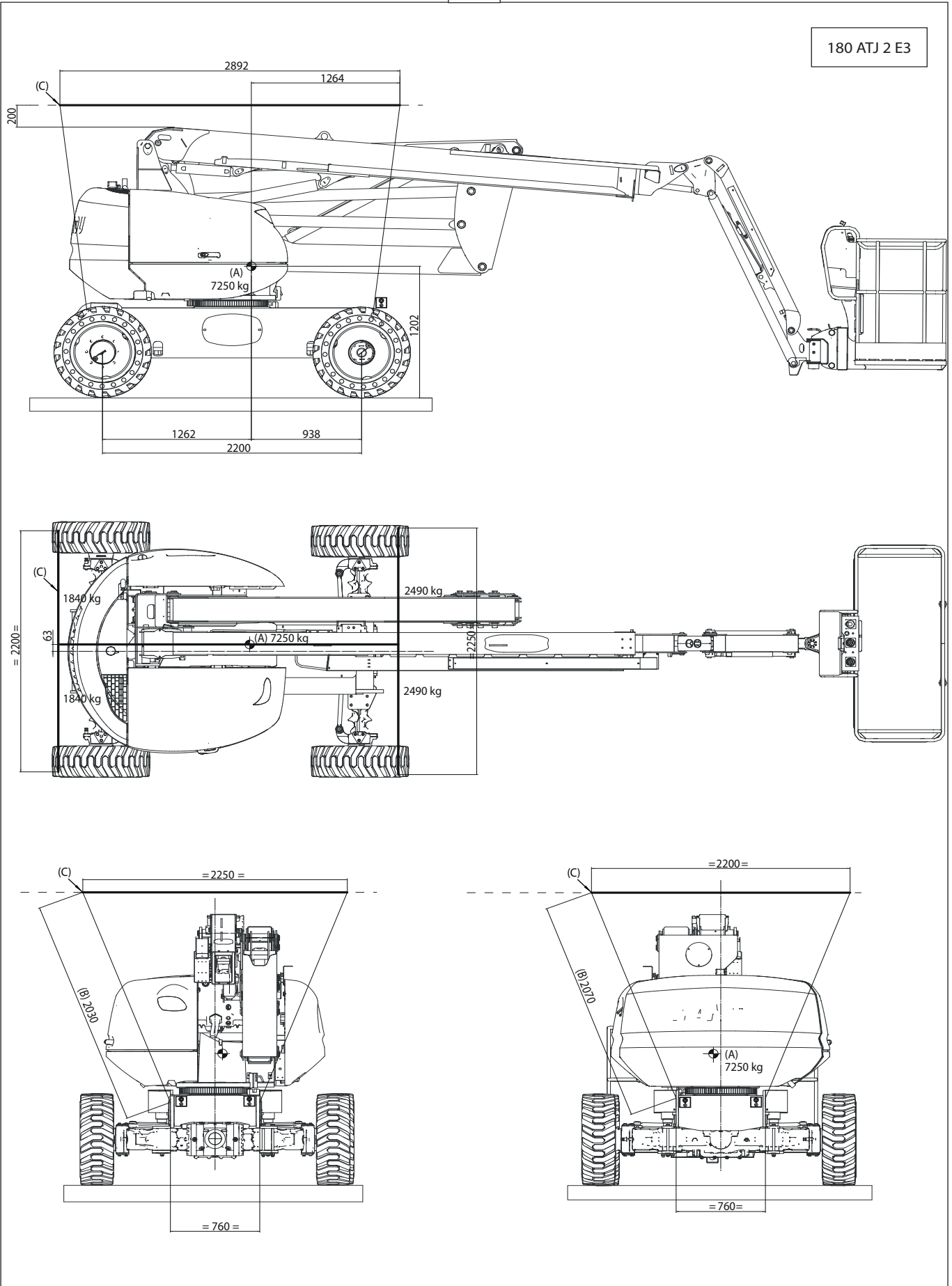

G4 - LIFTING PLATFORM ON A TRUCK BED

TRANSPORT

- See Section 2: LOADING / UNLOADING THE LIFTING PLATFORM.

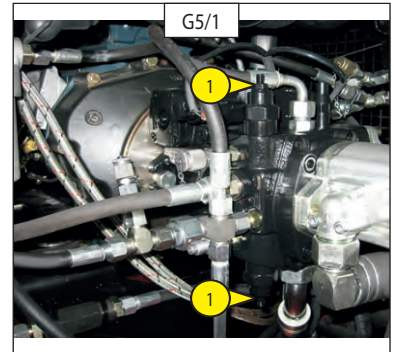

G5 - FREEWHEELING MODE

ACTIVATE

If the platform must be towed, follow the instructions below.



The platform may only be towed for a short distance and compulsorily by a machine with significant braking power in order to be able to hold it using a connecting bar between both machines.

- 1 – Chocking the platform.
- 2 – Hydrostatic declutching



Warning: before conducting this operation, take the necessary precautions: the machine will no longer have any brakes.

- Lift up the bonnet.
- Screw in the hydrostatic pump's HP restrictors 1 (Fig. G5/1) up to the sticking point + 1 turn and a half (No. 13 wrench and hex wrench).

3 - Mechanical declutching the rear axle

- Loosen the six lock nuts shown at 2 (Fig. G5/3) on the rear axle 1 (Fig. G5/2)
- Screw the bolts in the holes 2 (Fig. G5/3) up to the mechanical stop, following the predefined tightening order: tighten bolt 2A a quarter turn; then tighten bolt 2B a quarter turn; then tighten bolt 2C a quarter turn; then tighten bolt 2A a quarter turn (and so on until the mechanical stop is reached). Do the same with bolts 2D - 2E - 2F.

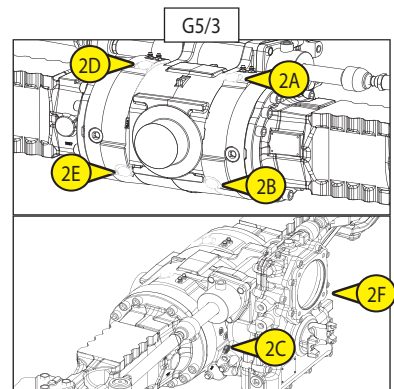

Do not force the bolts to tighten further once they are at the mechanical stop.



Failure to follow this procedure of progressive alternating tightening may damage the axle. Warning: after this operation, remember to release the mechanical anti-skid system. Follow the predefined loosening order: loosen bolt 2a a quarter turn; then loosen bolt 2b a quarter turn; then loosen bolt 2c a quarter turn; the loosen screw 2a a quarter turn (and so on). Do the same with bolts 2d - 2e - 2f.

4 - Testing the axle brake

- Check the braking system by disconnecting the coil 3 (Fig. G5/4) on the hydraulic unit on the chassis (to access the unit, remove the casing on the left-hand side of the chassis)
- Perform a translation movement.

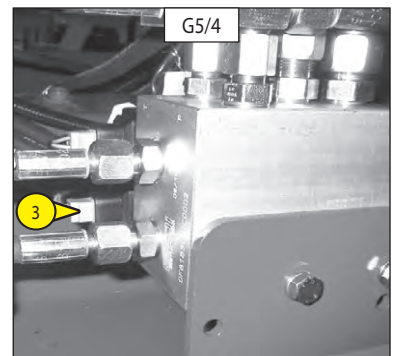

The platform should not advance.

- After the test, reconnect the coil.

G5 - FREEWHEELING

ACTIVATE

If the lifting platform must be towed, follow the instructions below.



The lifting platform may only be towed a short distance, necessarily by a vehicle with significant braking power so that it is capable of holding it and by means of a connecting bar between the two vehicles.

- 1 - Chock the lifting platform.
- 2 - Hydrostatic declutching



Warning: before conducting this operation, take the necessary precautions; the machine will no longer have any brakes.

- Remove the bonnet.
 - Screw in the HP restrictors 1 (Fig. G5/1) on the hydrostatic pump up to the sticking point + 1 and a half turns (No. 13 wrench and No. 6 hex wrench).
- 3 - Rear axle mechanical declutching
- Loosen the screw 1 (Fig. G5/2), without removing it.
 - Remove the pin Rep.2 (Fig. G5/2).
 - Tighten the screw 1 (Fig. G5/2).
 - Loosen the screw 1 (Fig. G5/3), without removing it.
 - Remove the pin 2 (Fig. G5/3).
 - Tighten the screw 1 (Fig. G5/3).



Warning: after this operation, remember to remove the mechanical anti-skid system.

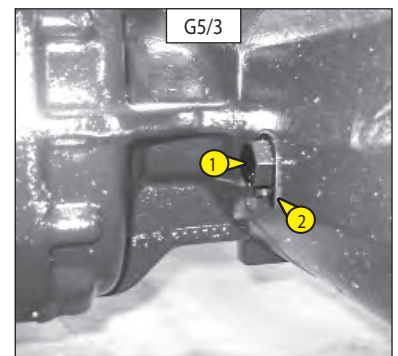
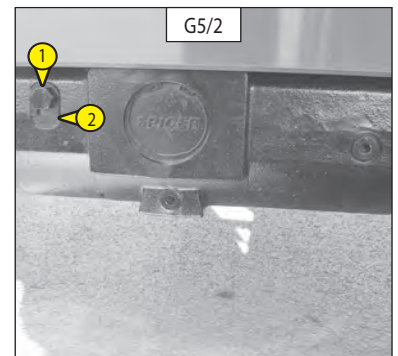
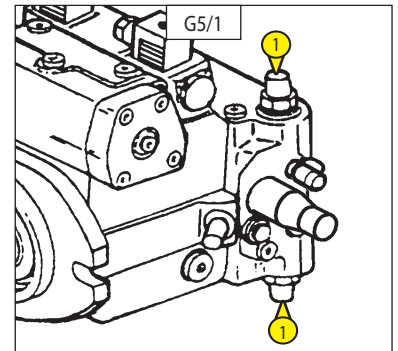

G6 - MAINTENANCE STAND

USE

If you have to make repairs to the arms, the turret, the engine, etc.
Follow the instructions below:

- From the base console, order the lower arms to rise until the upper joint is 1m above the counterweight (Fig. G6/1).

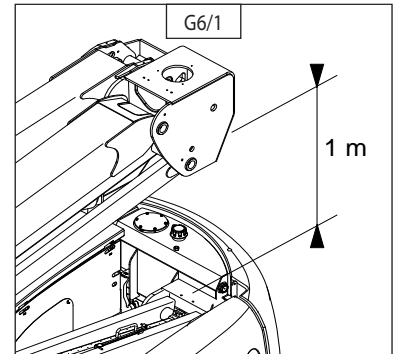

MACHINES WITHOUT MAINTENANCE STAND

- Place a sling connected to a hoist on the upper joint 1 (Fig. G6/1).
- From the base console, order the lower arms to lower until the belt is taut: then immediately release the controls.
- Switch off the engine and cut the power to the platform using the battery cut-out.
- Make the necessary repairs....

MACHINES WITH MAINTENANCE STAND

- Loosen the lock nut 2 (Fig. G6/2)
- Climb onto the back part of the chassis (beside the counter-weight), remove the maintenance stand 3 (Fig. G6/3) manually and insert the holding bracket 4 (Fig. G6/3); take care to lock this (Fig. G6/4).
- From the base console, order the lower arms to lower until the upper joint is in contact with the maintenance stand (Fig. G6/4 and G6/5): then immediately release the controls.
- Switch off the engine and cut the power to the platform using the battery cut-out.
- Make the necessary repairs...

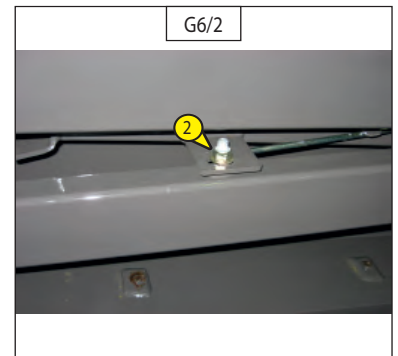

After these operations, follow the instructions below:

MACHINES WITHOUT MAINTENANCE STAND

- From the base console, order the lower arms to rise until the belt is loose: release the controls.
- Remove the sling from the upper joint, put the lifting platform in Transport position and switch off the engine.

MACHINES WITH MAINTENANCE STAND

- From the base console, order the lower arms to rise by 20cm: release the controls.
- Climb onto the chassis, remove the maintenance stand retaining bracket and then lower it (Fig. G6/3).
- Put the lifting platform in Transport position and switch off the engine.

